



BNL-102271-2014-TECH

RHIC/AP/167;BNL-102271-2013-IR

The ZCAL Conceptual Design Review

W. MacKay

October 1998

Collider Accelerator Department
Brookhaven National Laboratory

U.S. Department of Energy

USDOE Office of Science (SC)

Notice: This technical note has been authored by employees of Brookhaven Science Associates, LLC under Contract No. DE-AC02-98CH10886 with the U.S. Department of Energy. The publisher by accepting the technical note for publication acknowledges that the United States Government retains a non-exclusive, paid-up, irrevocable, world-wide license to publish or reproduce the published form of this technical note, or allow others to do so, for United States Government purposes.

DISCLAIMER

This report was prepared as an account of work sponsored by an agency of the United States Government. Neither the United States Government nor any agency thereof, nor any of their employees, nor any of their contractors, subcontractors, or their employees, makes any warranty, express or implied, or assumes any legal liability or responsibility for the accuracy, completeness, or any third party's use or the results of such use of any information, apparatus, product, or process disclosed, or represents that its use would not infringe privately owned rights. Reference herein to any specific commercial product, process, or service by trade name, trademark, manufacturer, or otherwise, does not necessarily constitute or imply its endorsement, recommendation, or favoring by the United States Government or any agency thereof or its contractors or subcontractors. The views and opinions of authors expressed herein do not necessarily state or reflect those of the United States Government or any agency thereof.

Relativistic Heavy Ion Collider

Brookhaven National Laboratory

RHIC/AP/167

Subject: The ZCAL conceptual design review, Oct. 2 98

To: William MacKay(*), Dan Weiss(*), Tom Ludlam, Tom Clifford(*), Gary McIntyre(*), T.R. Muller(*), H.C. Hseuh(*), L. Remsberg, A. Sukhanov, A. Olszewski, M. Baker, Yousef Makdisi(*), Hank Crawford, Steve Musolino(*), Asher Etkin(*), Dejan Trbojevic(*), Brian Oerter(*), Edmundo Garcia, Sebastian White, Alexei Denisov, Steve Peggs(*), Angelika Drees

From: Angelika Drees, Waldo MacKay(*), Sebastian White

Date: October 14, 1998

Cc: M. Harrison, S. Ozaki, T. Ludlam, T. Robinson, W. Christie, D. Barton, J. Sondericker, S. Aronson, Tim Hallman, Michael Marx, Flemming Vidabaek, Bolek Wyslouch

1 The Committee

The members of the committee are marked with a (*) in the lines above.

2 Agenda

The design review was held to discuss the status of the ZCAL¹ project and to present its employment as an accelerator diagnosis tool in RHIC. In addition safety issues have been addressed. The following topics were presented at the review:

	<u>Topic</u>	<u>Speaker</u>
1.	Project Overview	S.White
2.	Construction of the ZCAL	M.Murray
3.	Installation in RHIC	G.McIntyre
4.	PMT selection and readout scheme	E.Garcia
5.	RHIC Interface and HV control	A.Drees

¹Zero Degree Calorimeter

3 The Topics

The copies of the transparencies are attached to the minutes and are referred to as [1] to [5].

3.1 Project Overview

The ZCAL consists of two detectors at either side of each experiment (BRAHMS, STAR, PHENIX, PHOBOS), about 20 m downstream and upstream from the interaction point respectively. The devices are placed between the blue and yellow beam pipes in the warm section between the DX and the D0 magnets. One detector is composed of three modules, each containing 27 tungsten plates, 26 optical fiber ribbons and one photo tube mounted at the top of each module for readout. All detectors are supposed to be identical. A project overview, the design of the ZCAL and test beam results from first proto types are presented in [6]. The item outlined during the review can be found in [1]. Items being discussed during the presentations were:

- The ZCAL is not designed for pp or uneven (pAu) collisions although geometrically possible.
- The energy resolution of the calorimeter has been successfully tested at CERN at two energies, 100 GeV and 160 GeV.
- The energy resolution does not change when the detector is extended from 3 to 4 modules (each having 2 interaction lengths).

The following installation schedule was agreed to:

- Two detectors will be installed at BRAHMS by end of Feb. 99.
- The six other detectors will be in place by end of May 99.

3.2 Construction of the ZCAL

Copies of the presented transparencies [2] are attached to the minutes. The safety issues concerning the weight of the modules and the lifting eyes were discussed during this presentation and are summarized in [7]. The appropriate action items are listed there as well.

3.3 Installation in RHIC

The copies of the transparencies [3] are enclosed. Each of the ZCAL modules has 6 alignment fiducials. The longitudinal position of the detectors is not a crucial issue and the requirements for the alignment are loose ($\mathcal{O}(\text{mm})$). These

requirements will be easily met by the standard RHIC survey procedures. The detector stand design has started and will be done in close collaboration of W. Christie and Gary McIntyre. No problems are expected from this point.

3.4 PMT selection and readout scheme

Two options for photo tubes were discussed: XP2262B and RCA 8575. Two of each type were tested in a test setup. Results can be found in the copies of the transparencies [4]. The preferred type is RCA 8575. Texas A&M University has at least 12 tubes of this type available [2] and most likely enough to equip all IRs. A minimum of 24 tubes is needed plus a reasonable number of spares. The sample going to be used will be tested during January and February 1999. Drawings of the bases should be sent to Asher Etkin.

Three experiments agreed on a readout scheme², which can be found in [4]. These experiments are: BRAHMS, PHENIX and PHOBOS. The analog signals from the photo tubes will be transformed into 3 logical signals: single rates from either side and a coincidence rate. The electronics needed for that are under the responsibility of the experiments and will be transferred to RHIC controls. STAR will split the analog signal at the photo tubes³ and not provide any logical signal to RHIC. The expected single beam neutron emission rate is about a factor of 10 higher than the coincident rate. The correlated signal is expected to be ≤ 10 kHz.

3.5 RHIC Interface and HV control

Copies of the transparencies [5] are attached. RHIC requests relative luminosities only. Responsibilities for the ZCAL project will be shared between the experiments and the RHIC accelerator division as follows:

- The experiments are in charge of the ZCAL maintenance, spares and any technical problem.
- The experiments are calibrating the HV settings of the PMTs. They have to notify the RHIC control room about any change in the HV settings.
- In case of solution A experimenters are fully responsible for adjusting and tuning the readout electronics.
- In case of solution A the experiments are obliged to make the logical signals (i.e. input for the scalers) available to RHIC at any requested time.

²solution A

³solution B

- RHIC provides the HV power supply and control. The HV control supports restricted access to the HV calibration and enforces the notification to the control room.
- RHIC provides the scaler including software and control.
- In case of solution B RHIC has to supply and adjust its own electronic readout chain.

The ZCAL working group agreed on a list of responsables (see table 1) and a plan for the detector installation and maintenance beginning of this year [8]. The list of contact persons or responsables respectively, which can be found in [8], still applies while the readout scheme chosen by the particular experiment changed in 2 cases, BRAHMS and PHOBOS, compared to [8]. While

Exp.	contact	scheme	PS		scaler	
			location	cabling	location	cabling
BRAHMS	M. Murray	A	trailer	exp.	trailer	exp.
STAR	W. Christie	B	1006 B	RHIC	1006 B	RHIC
PHENIX	S. White	A	1008 B	RHIC	ctrl. room	exp.
PHOBOS	E. Garcia	A	trailer	exp.	trailer	exp.
RHIC	A. Drees					

Table 1: *List of electronic locations and responsables for the ZCAL project. The notation for the scheme refers to the memo [8].*

in three cases (BRAHMS, STAR, PHOBOS) the location of the power supply and the RHIC scaler is the same, this is different for PHENIX. The committee was concerned about the formation of severe ground loop problems due to the power supply being installed in the service building and the scaler being installed in the counting room. This problem has to be investigated by the PHENIX experiment and S. White. The STAR experiment requires an electrically isolated split for the analog signals from the ZCAL detector. The particular device which might be selected has still to be approved and confirmed by Hank Crawford. The logic transforming the analog signal into countable rates has to be applied by A. Drees. This crate will be located in the service building 1006B.

4 Action Items

- The responsibilities in the ZCAL project have to be made transparent to everybody involved. Details are outlined in the section above in this

memo.

- The RHIC installation group has to agree on all installation details.
- Define cable routes for HV and signal cables for each location with particular attention to ground loops.

5 Safety Issues

Safety issues are summarized in the safety subcommittee minutes [7] and are attached to this memo.

6 Conclusion

No further review meetings are necessary provided that the the action items listed above are resolved. The RHIC installation group does not see any particular problems with the ZCAL design. A list of names and responsibilities is available, but details should be worked out and made public. The experiments are in charge of the ground loop investigations.

References

- [1] S. White, copies of transparencies, RHIC Zero Degree Calorimeter Review, Oct. 2 1998.
- [2] M. Murray, copies of transparencies, Oct. 2 1998.
- [3] G. McIntyre, copies of transparencies, "Installation outline", Oct. 2 1998.
- [4] E. Garcia, copies of transparencies, "Photomultiplier tubes and readout", Oct. 2 1998.
- [5] A. Drees, copies of transparencies, "ZCAL-RHIC interface", Oct. 2 1998.
- [6] The ZCAL working Group, "Zero Degree Calorimeters for RHIC", <http://www.rhic.bnl.gov/~white/proposal.ps>, Apr. 21, 1998.
- [7] Y. Makdisi, "Minutes of the RHIC Experiment Safety Subcommittee meeting", Oct. 2 1998.
- [8] A. Drees, <http://www.rhichome.bnl.gov/People/drees/>, "A RHIC ZCAL interface proposal", Feb. 12, 1998.

Oct 2 1998

RHIC Zero Degree Calorimeter Review

- Role of the ZDC system in RHIC
- Scope of the Project
- Demonstration of Principle and Prototype test
- Goals and Schedule

Role of the ZDC System

- ZDC's are a set of devices to be used for monitoring Luminosity in Heavy Ion Collisions
- Devices sensitive to Most of real collision rate and suppressed response to Backgrounds
ie- Beam-Gas Interactions and Upstream losses
 - They absorb and Measure the Energy of non-interacting Beam Fragments
 - The Luminosity Monitor rate consists of an “in-time” coincidence of Fragments
in Each beam Direction
- Rate has approximately equal contributions from Nuclear Interactions
and Coulomb Breakup (latter has prominent 1-n ie 100 GeV peak in energy spectrum)

Scope of the Project

- Calorimeters being built for 4 experiments* 2 beam directions
- Each of 8 calorimeters has 3 Photomultiplier tubes
- All zdc's built from common design - 1 set in Texas A&M and 3 in Frankfurt
- Project has participation from all experiments

Performance Requirements

- Energy Resolution for 100 GeV neutron ~20%
- Flat response over 2-3 cm radius around forward direction
- (a 200-300 psec resolution - useful for Lum profile measurement)

Status of Project

- Cross section Calculated => correspondence between rates and Luminosity scale

$$\sigma (->1 \text{ or more } n, \text{ in each beam direction}) = 11.0 \text{ b}$$

- Fragmentation Measured in a CERN Beamtest
 - => at least 1 n always present in Nuclear Int,
 - ZDC energy a useful tool in characterizing events
- 1st Prototype built and tested in 100, 160 GeV Proton Beam

Goals , Schedule, Responsibilities

Goals of the Project

- Produce All calorimeters, ready for first collisions
- Provide High Voltage and common controls for PMT's
- Commission in beam or Cosmic Ray test
- Provide Scalers to record Luminosity and Background Rates for each experiment

Milestones

- Mechanical Assembly in progress- today
- Screen 24 pmt's and test bases- Jan/Feb '99
- Install Stands, Cables- April '99
- First System test in Spring '99
- All calorimeters ready for installation June '99

Luminosity Monitoring

For AuAu collisions at RHIC cross section for the correlated loss of one neutron from each Au nucleus is estimated at 3.9 ± 0.5 barn. The uncorrelated rate measures beam gas interactions.

Such neutrons have

$$p_T \approx 100 \text{ MeV}/c \Rightarrow \theta \leq 2 \text{ mrad}$$

To measure them we need

- $\sigma E = 20\% @ 100 \text{ GeV} \Rightarrow 1$ neutron peak
- $\sigma T = 200 \text{ ps} \Rightarrow 5 \text{ cm}$ vertex resolution
- Radiation resistance $\geq 200 \text{ G/year} \cdot 10$ year
- Width $\leq 10 \text{ cm}$ to fit between beam pipes
- 2 calorimeters ready at machine startup

Tungsten cerenkov calorimeters tested at CERN meet these requirements.

The Calorimeters

Cu & W prototypes were tested at CERN. Each was 8 interaction lengths long, 10cm wide & 10cm high with 5mm plates tilted at 45 degrees with respect to the beam & 0.5mm PMMA fibers.

The Cu tests were less complete due to time & beam limitations. Monte Carlos predict that W will have considerably better energy resolution than Cu because of better shower containment.

The W prototype had an energy resolution of 20% at 100GeV & was linear with energy. This will give a good separation between 1 & 2 neutrons. The 4 separate modules were intercalibrated with muons. The time resolution of the first module was 115ps & 229ps in the second module. This implies that the calorimeters should be able to locate the z position of the interaction within 5cm. The ZDC group has chosen W. Very little energy was observed in module 4 & so only 3 modules are needed. The height will be increased by 25% to shield the fibers between the active region & the phototubes.

Zero Degree Neutrons versus Centrality

The measurement of centrality via the energy of beam fragments is well understood at AGS & SPS energies. The main advantages are

1. Consistency of normalisation between different experiments
2. Minimal bias on other measurements at mid-rapidity.

NA49 studied forward neutron multiplicity versus centrality by looking at the energy in the ring calorimeter, E_R , versus energy in the zero degree veto calorimeter E_V for various magnetic fields. Both very peripheral & very central collisions produce few neutrons at zero degrees. However a soft cut on the BRAHMS beam-beam counter will allow the ZDCs to serve as a centrality trigger.

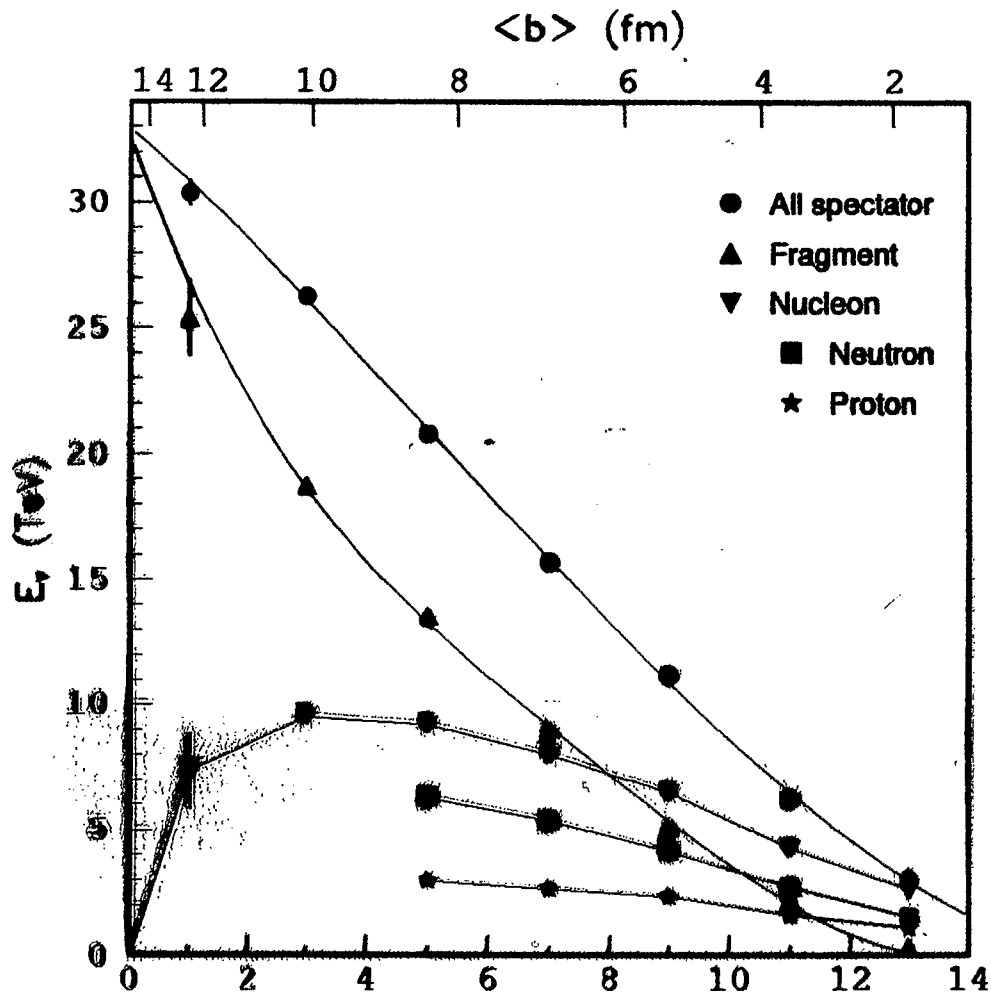

Radiation Damage

During AuAu running the calorimeters should suffer a radiation dose of 200^{+200}_{-100} G/year from, EM dissociation, beam gas & beam-beam interactions. This should cause an attenuation of 4 dB/m may force us to replace the PMMA fibers by quartz ones. There is some controversy as to whether this damage is accelerated by oxygen. If oxygen is a problem the effect may be eliminated by blowing dry nitrogen over the fibers.

The calorimeters may also suffer from "accidental" radiation damage. The levatron has dumped about 10% of the total beam energy into a single magnet, twice in 13 years. This would probably damage the PMMA fiber & tubes as well as the magnet. However in such a case it should be possible to repair the calorimeter within a couple of weeks during which time cause of such a dump would be under investigation. A more likely occurrence is for a few bunches to hit the calorimeters during injections. This could happen a few times a year. The energy of these bunches would be 10% of the beam energy & the total dose from such an incident should be less 10G. This should not seriously effect calorimeter operation.

IHEP is doing R&D for quartz fibers which are very radiation resistant. They may also improve the energy resolution since they accept light over a smaller range of angles. This tends to reduce the response to electrons which propagate almost isotropically in the calorimeter as compared to hadrons which are more forward peaked. This reduction of the electron response should bring the signal ratio e/π closer to 1 & thus improve the energy resolution.

Construction at Texas

Responsibilities and effort:

- Design & procure tungsten plates
- Integrate ZDCs into BRAHMS
- Two PhDs plus engineer & machinests

Safety:

- Weight \approx 50Kg, lift fixture tested to 135Kg. Bolts can carry 205Kg before shearing.
- HV & signal cables will be separated
- Bases will tested to twice normal voltage + 1000V.
- No N_2 system required in first year
- Only plastic component is fiber

Components:

- All Plates delivered
- Thickness 3 * better than specs
- Some holes slightly off center
- Fiber bundels arrived today
- 12 RCA 8575 PMTs available

Construction:

- 1 Module constructed
- Choose tube & design magnetic shield, 1 week
- Casing needs \approx 150 hours machine shop time
3 weeks + 1 week nickel plating
- Assemble modules, 2 days each
- Design & build stand for cosmic ray test
- Test with cosmics, 3 days each

Schedule:

- Start construction of modules in mid October
- Begin cosmic tests in early November
- Ship to BNL in early January

Software:

- Current Monte Carlo gives good description of CERN tests
- Code has been adapted to BRAHMS format
- Testing needs to be done at RCF
- ZDC need to be intergrated into BRAHMS DAQ.
- Michael will be liason between RHIC & BRAHMS

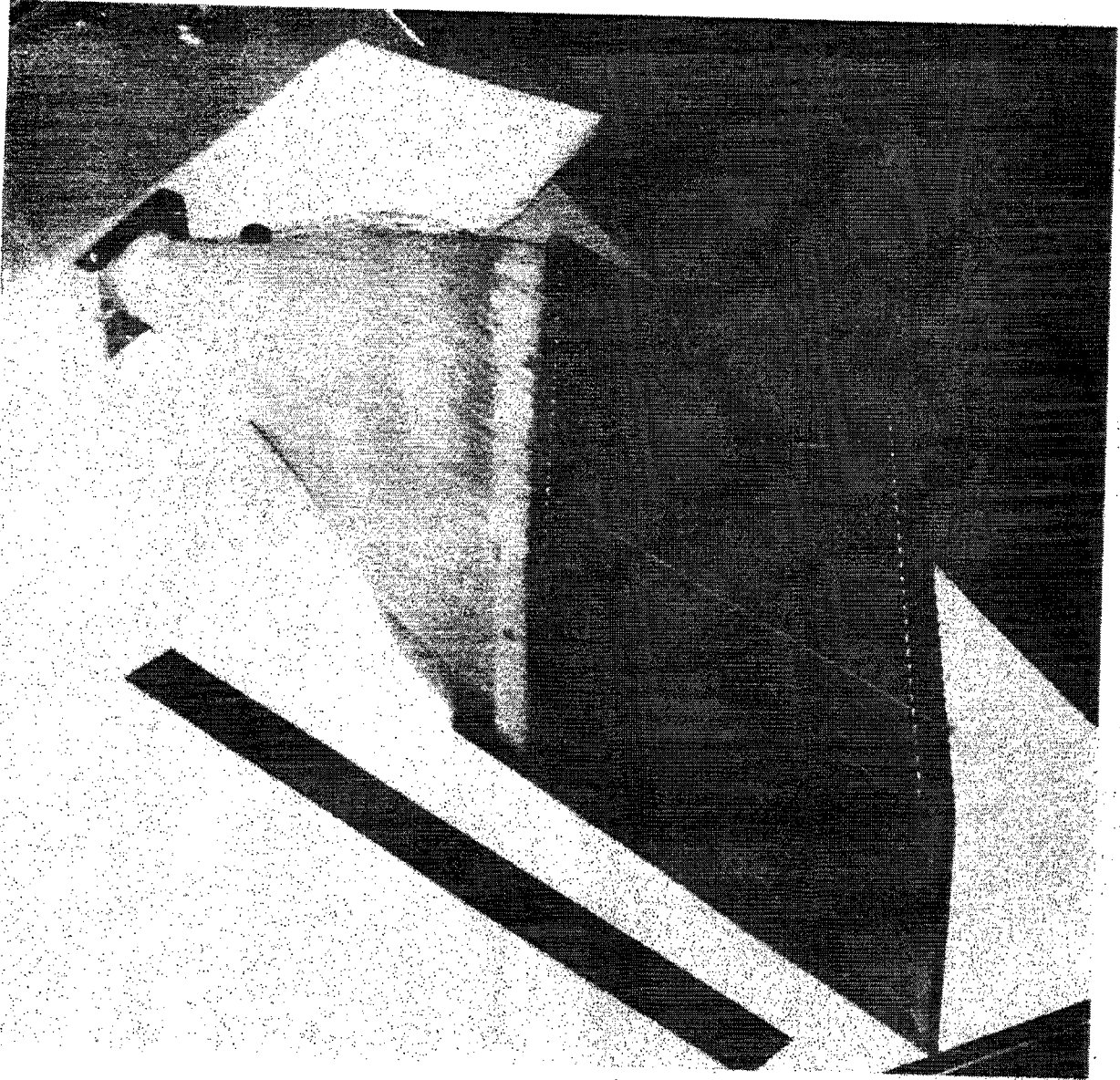

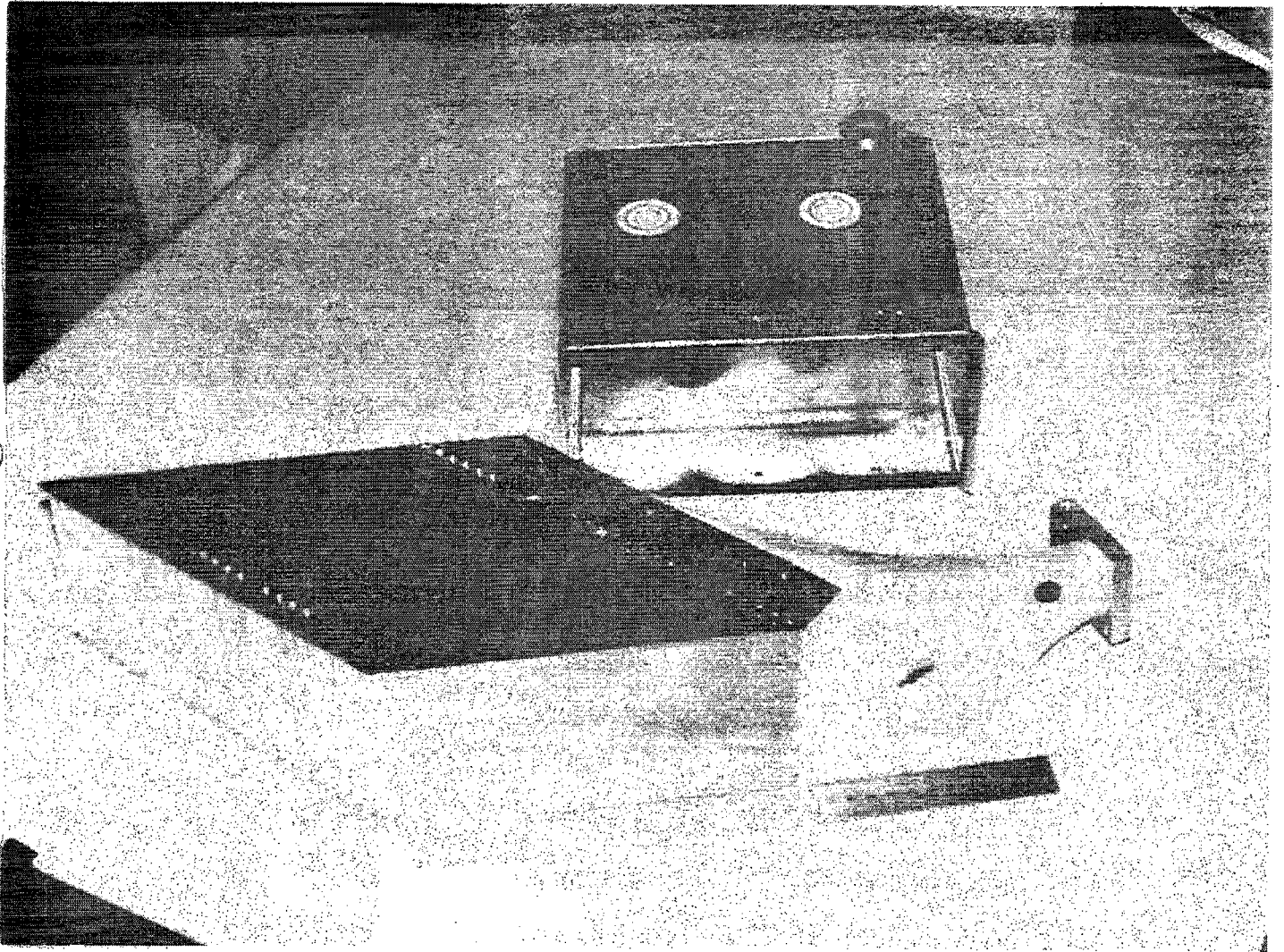

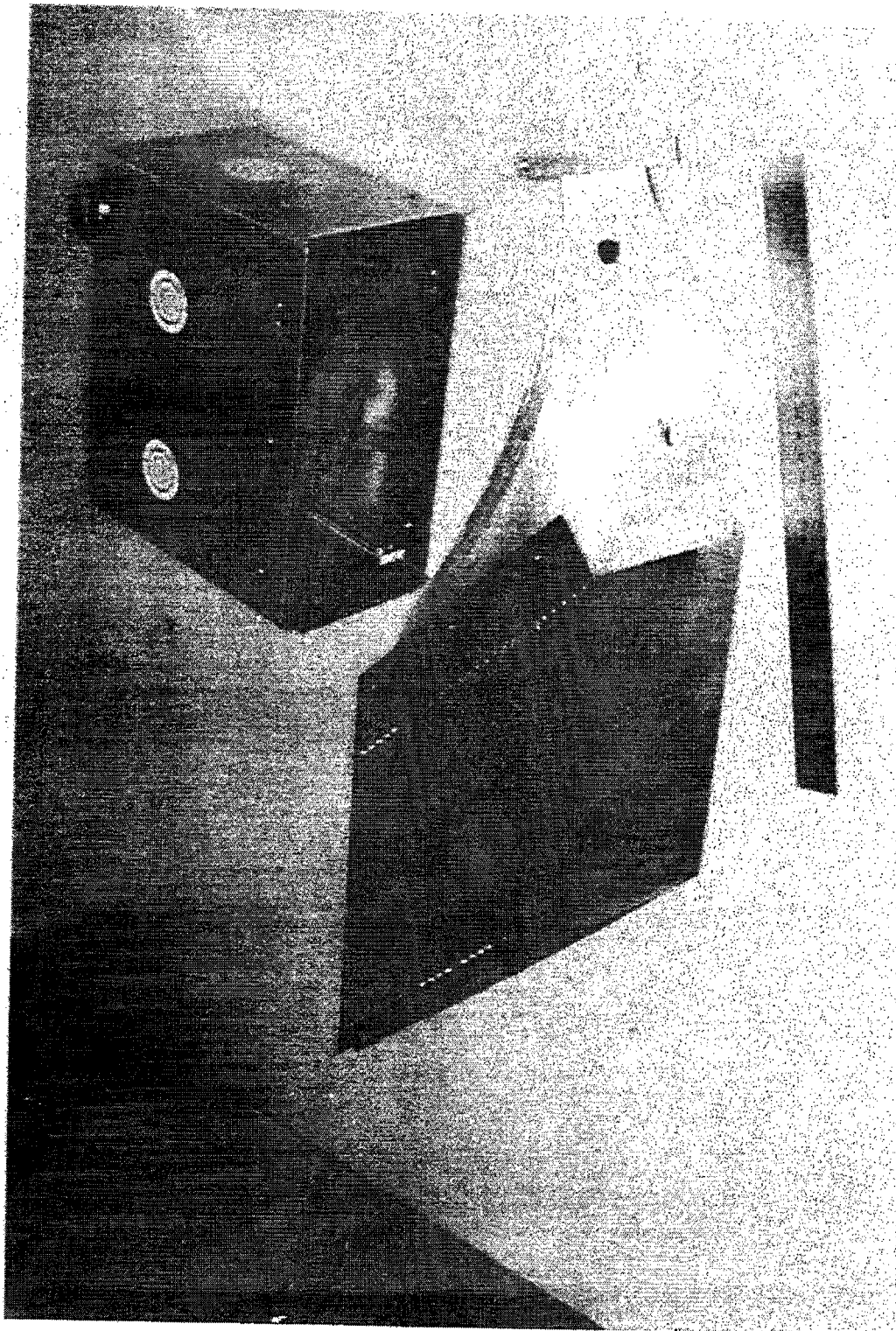

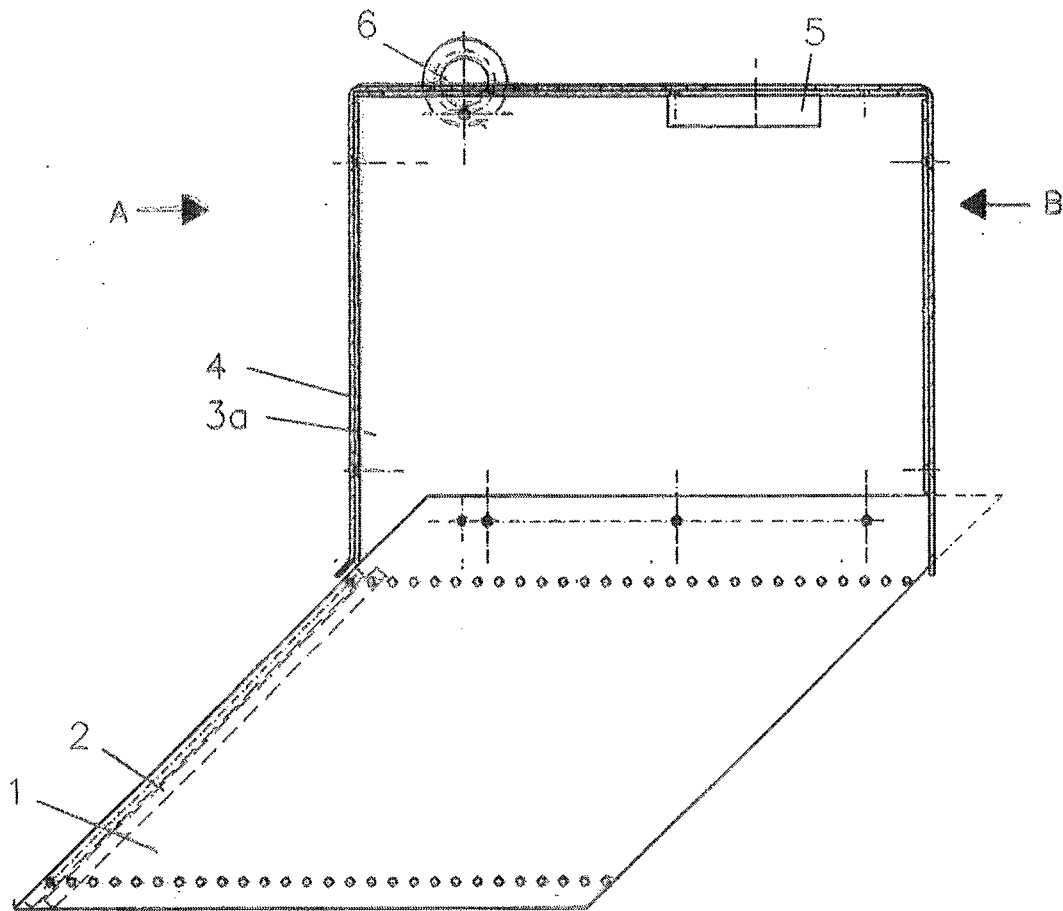

M 1:2

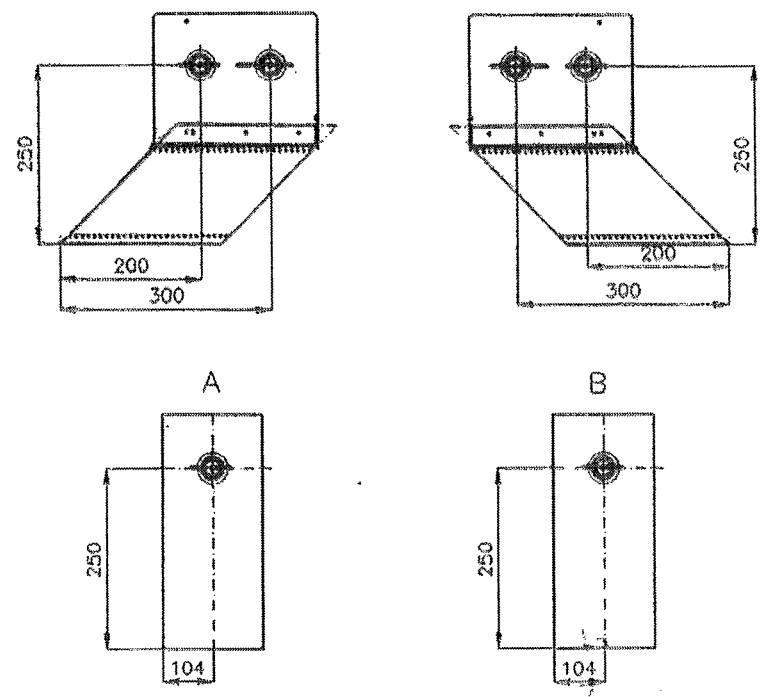

reference points

Calorimeter Module

Institut für
Kernphysik
Frankfurt/M

**Zero Degree Calorimeter
Design Review
October 2, 1998
Installation**

Installation Procedure

- **Installation the same at Sectors 1, 5, 6, 7, 8, 9 and 10.
-Sector 2 is an additional 18" higher, may use crane.**

- **All Z-Cal segments (3) transported to installation location.
- Cart or wagon**

- **Placed individually on stand with "engine" hoist using eyebolt.
- Hoist capacity 1000 lbs.**

- **Preliminary survey done linking each segment to each other.
- Utilizes survey points on each segment.**

- **Final survey done, all 3 segments treated as single component.
- Utilizes adjust mechanism in stand.**

- **Due to minimal clearance, Z-cal must be removed each time
respective beamtubes are baked out.**

**All required equipment, but transport cart, available from
Installation Section.**

**Zero Degree Calorimeter
Design Review
October 2, 1998
Installation**

Design Requirements, within Z-cal, for Proper Installation

- **Lifting provisions through the center of gravity.**
- **Survey points (4) on each segment, visible when on stand.**
- **Positioning mechanism for calorimeter mounting plate.**
- **Stand must avoid DX/D0 chamber and straddle transfer line.**
- **Preliminary Layout**

Z-CAL INSTALLATION OVERALL PRELIMINARY LAYOUT

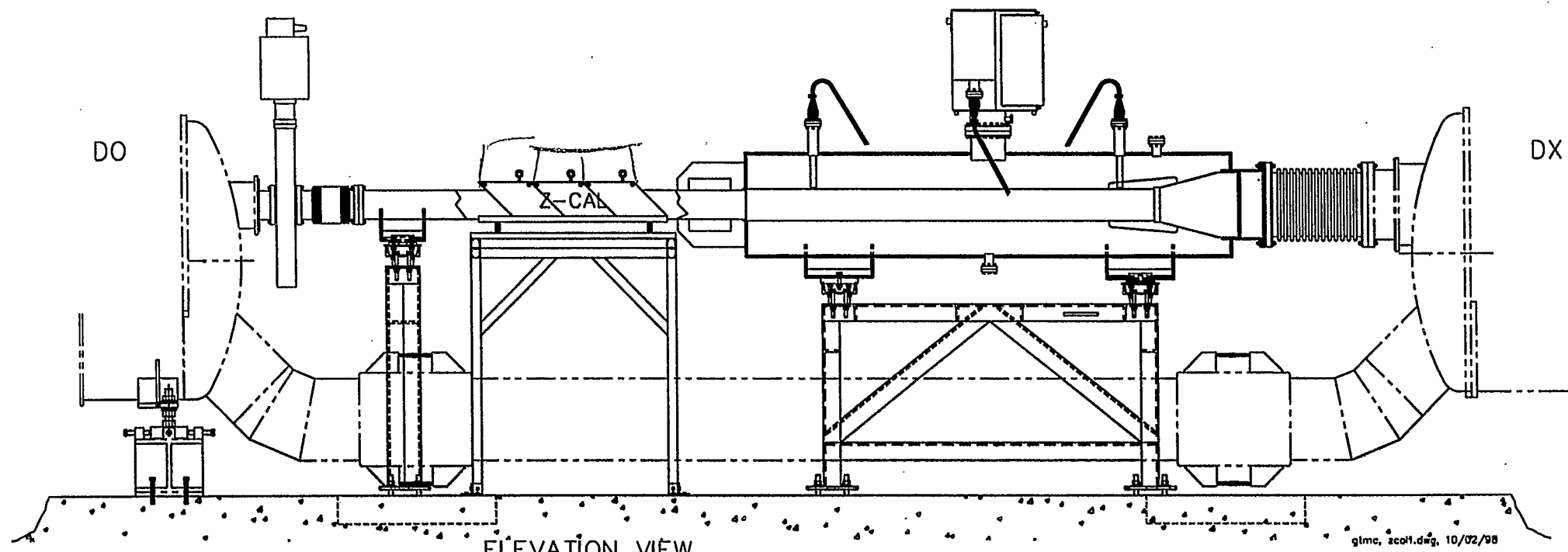
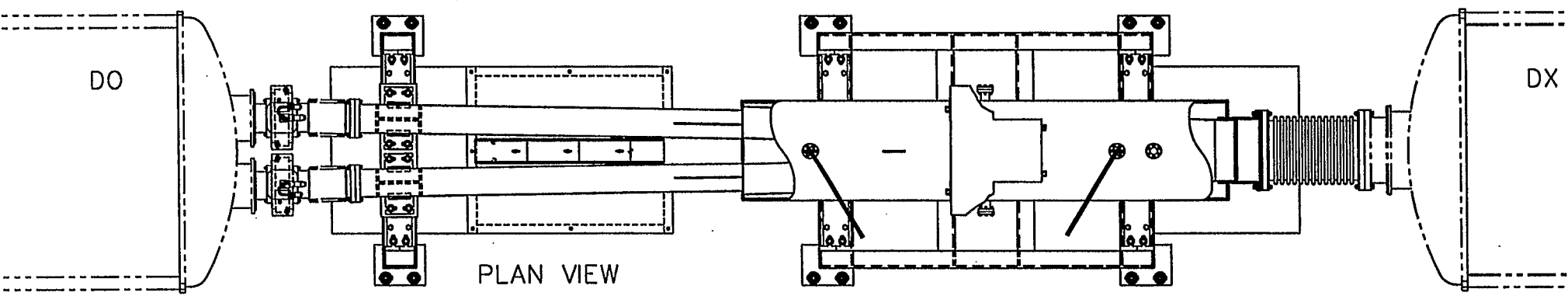

Z-CAL INSTALLATION

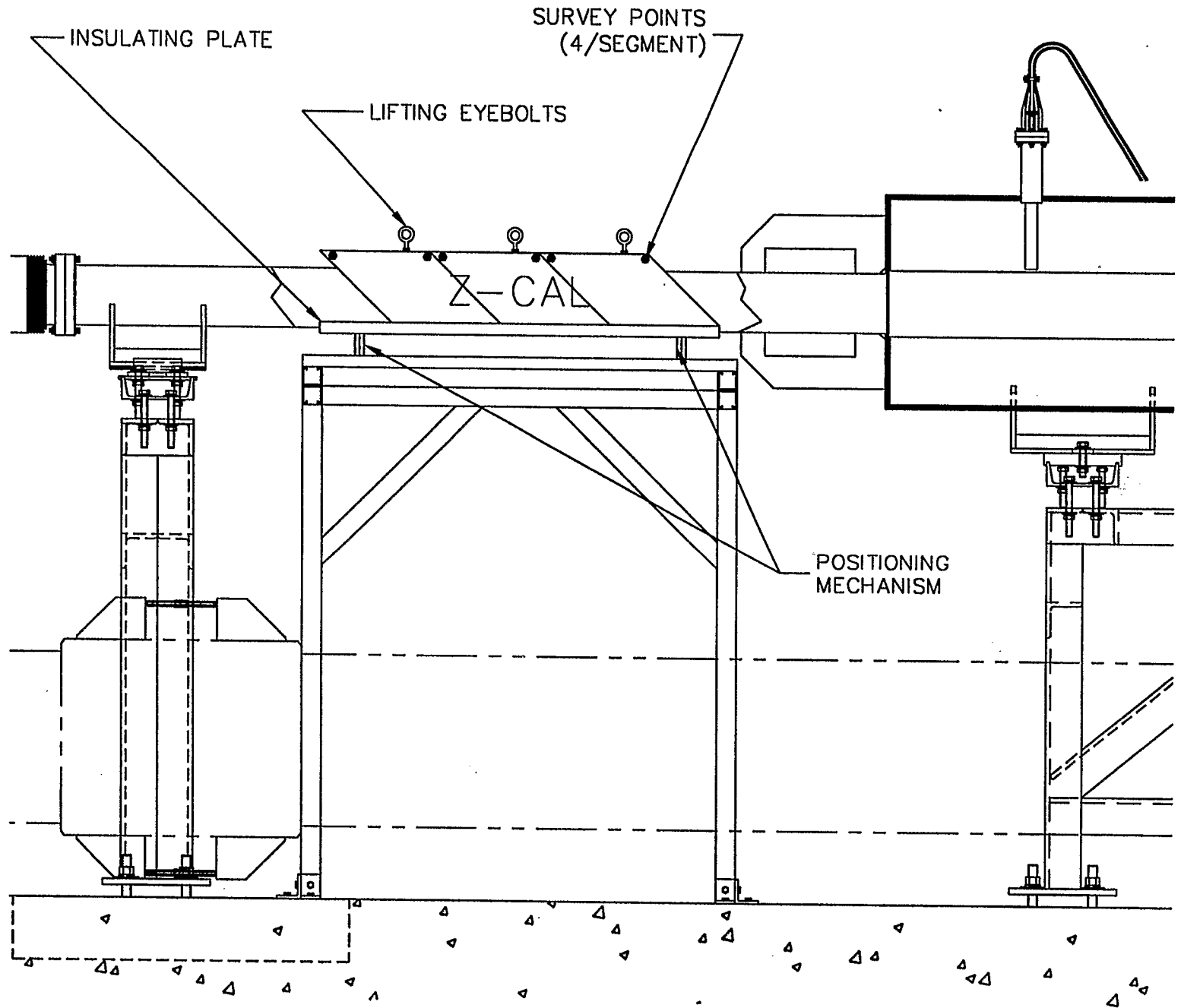

Z-CAL INSTALLATION

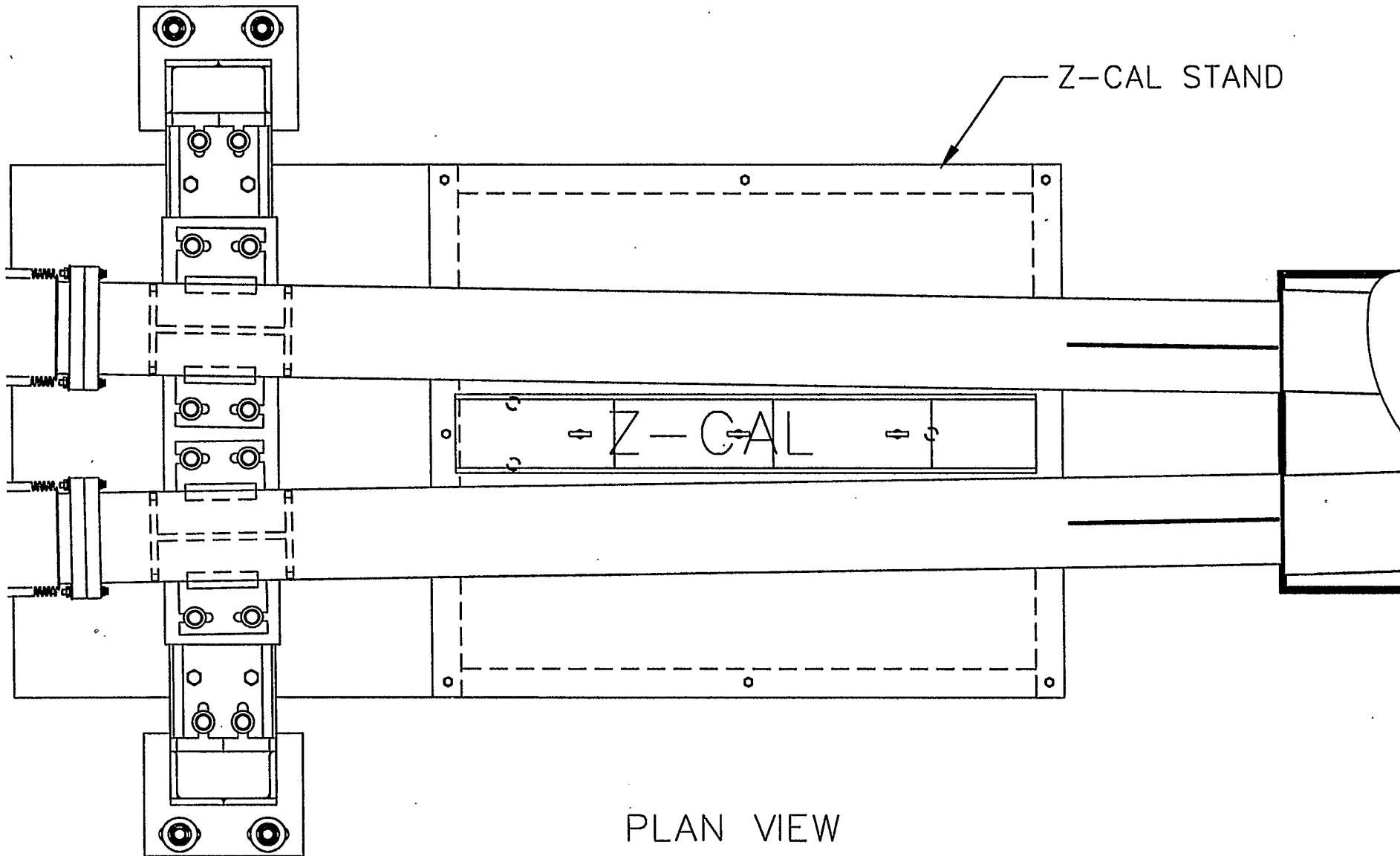

PLAN VIEW

Z-CAL INSTALLATION

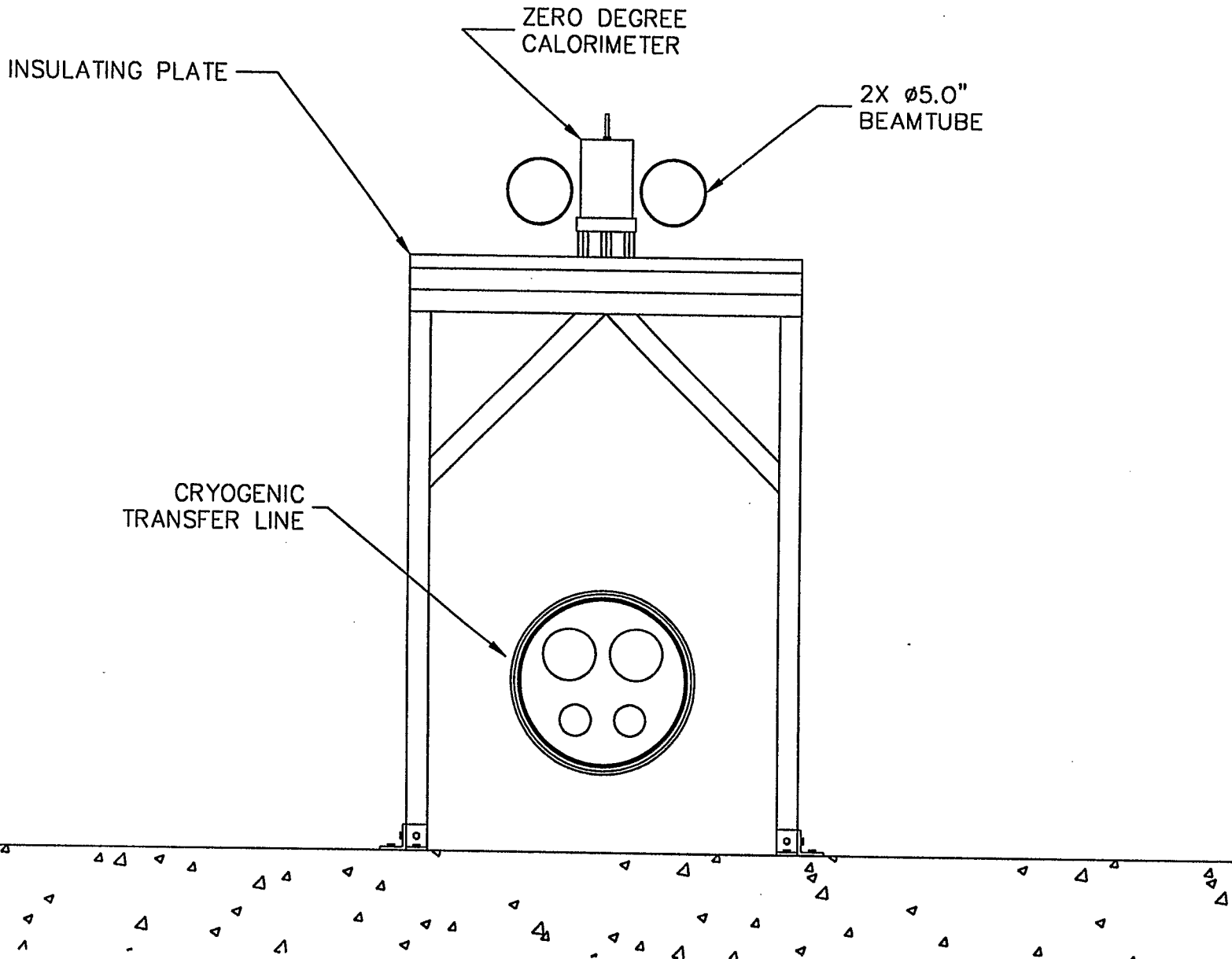

FRONT VIEW

Photomultiplier tubes and readout

Outline:

- phototubes
- readout layout
- electronic and logic connections
- dynamic ranges

photomultiplier tube choice

- ∃ tubes characteristics relevant to the ZDC design:
 - œ response time
 - œ pulse linearity
 - œ photocathode uniformity
 - œ cost and availability
- ∃ two options:
 - œ Philips XP2262B
 - œ Burle (RCA) 8575

tube	photocathode diameter	quantum efficiency	typical gain ⁷	rise time	max. linearity	typical voltage
xp2262b	>44.0 mm	25 %	3 x 10 ⁷	2.0 ns	100 mA	1850 V
8575	>45.7 mm	25 %	2 x 10	2.8 ns	150 mA	2000 V

photocathode uniformity

- ∃ uniformity was measured using LED's for pulse high and scanner to change position along the tube's face
- ∃ uniformity response along the diameter of photocathode for each tube was similar for different directions
- ∃ since ZDC needs uniform response over 4 cm. diameter, we prefer RCA8575

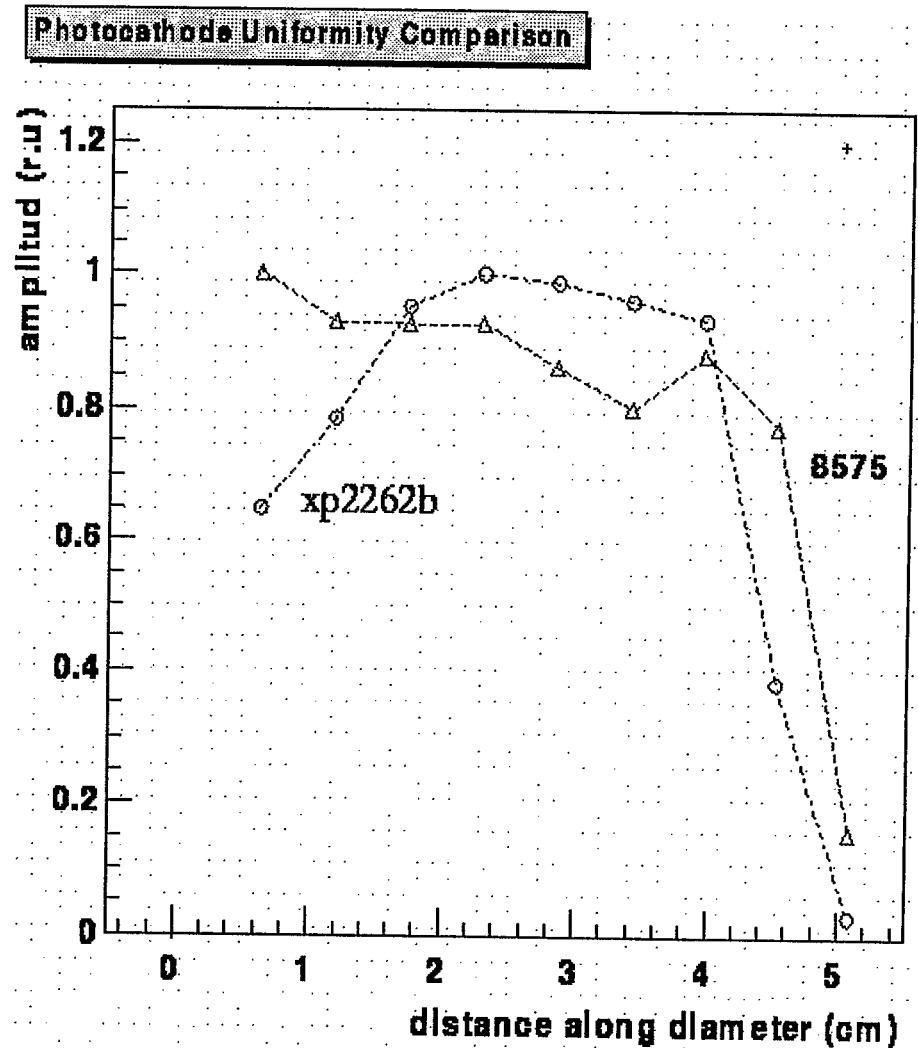

schematic layout of the ZDC system

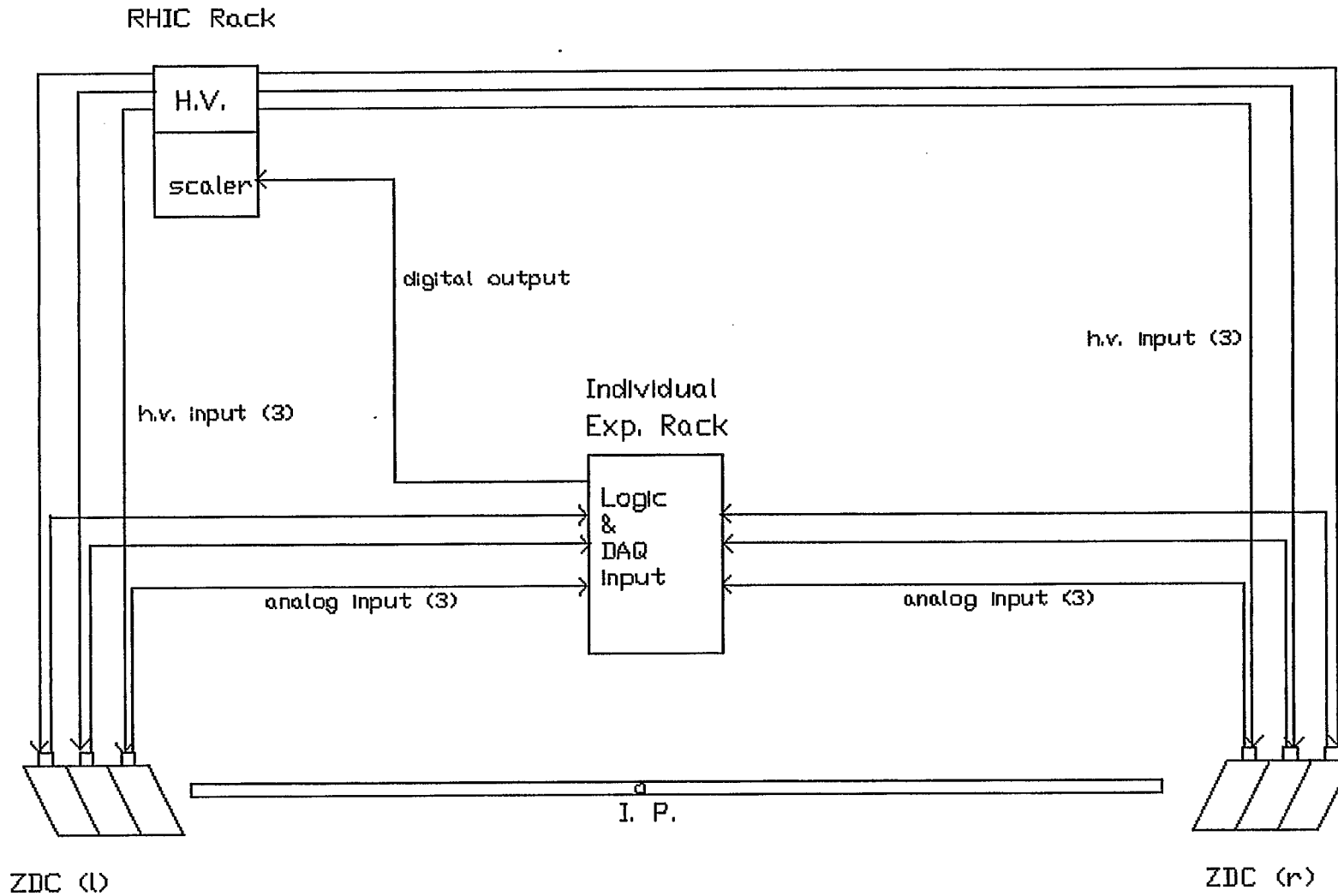

October 98.

Edmundo Garcia, University of Maryland.

coincidence logic and electronics

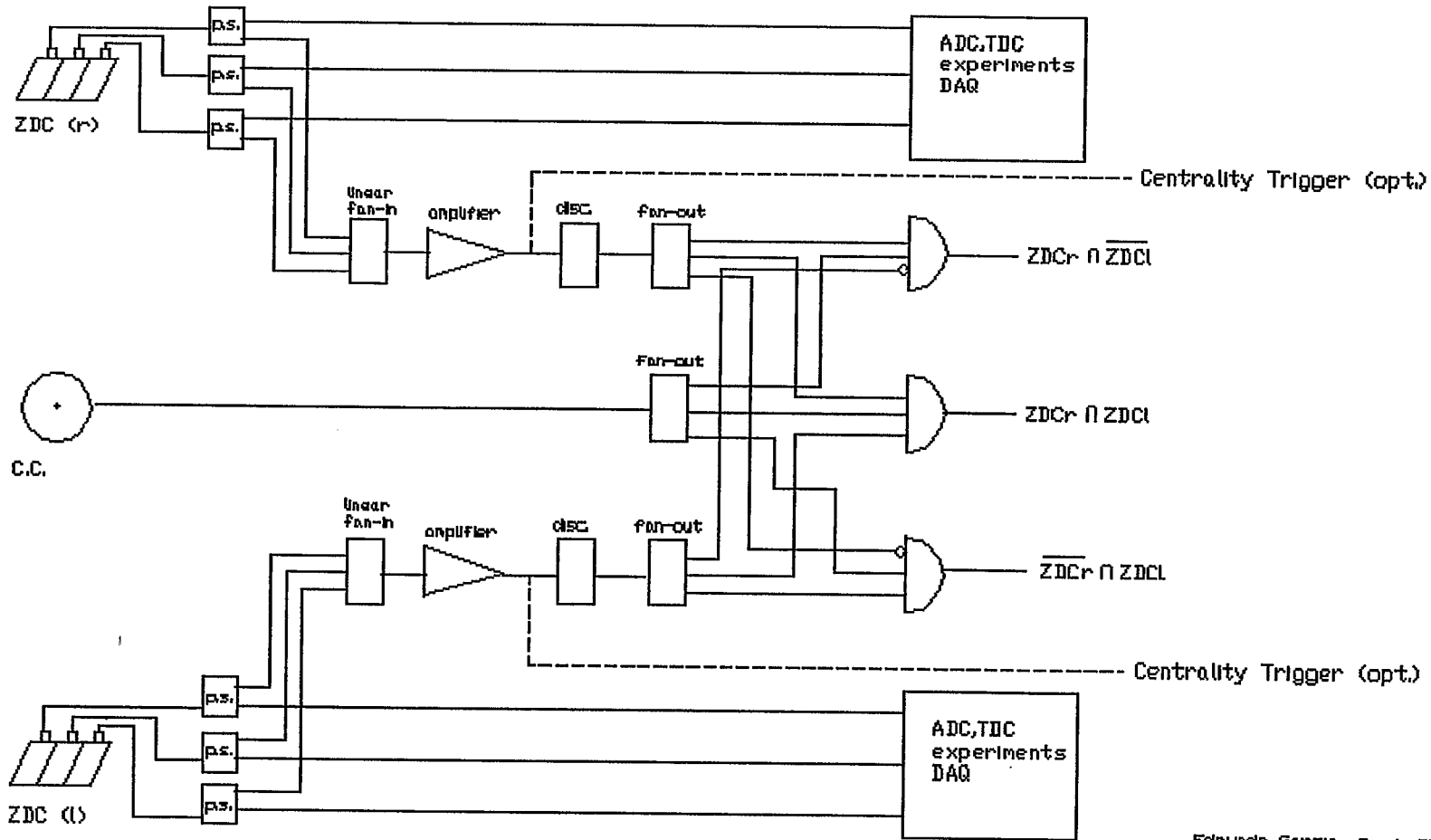

Edmundo Garcia, Sept. 98

October 98.

Edmundo Garcia, University of Maryland.

dynamic range

- relative amplitudes for the interactions with one muon, one proton and thirty protons:

particle type	module 1	module 2	module 3	sum
1 20 GeV muon	10	10	10	10
1 100 GeV proton	380	42	4	426
30 100 GeV protons	7000	3000	740	1040

- based on the response of the prototype modules in the CERN test run and on Monte Carlo simulation
- if maximum pulse current set to 100 mA, for largest amplitude, can be mapped into a relative current table

dynamic range

particle type	module 1 (mA)	module 2 (mA)	module 3 (mA)	sum (mA)
1 20 GeV muon	0.14	0.14	0.14	0.44
1 100 GeV proton	5.40	0.60	0.05	6.70
30 100 GeV protons	100.0	42.29	10.57	152.86

- ∃ Choosing the ratio of 1/3 to the fan-out and 2/3 to the experiments DAQ, it will be possible to record signals from 1 muon to 30 GeV protons, (for standard ADC (TDC) the dynamic range is of about 1000)
- ∃ For the summed signal assuming a 50 Ω impedance and an amplification factor of 6 it will be possible to discriminate at a level fully efficient for a single 100GeV neutron (i.e. less than 60 mV)

final notes

- ∃ there is a set of 30 RCA tubes from TA&M, the set of tubes has to be screened to choose the best ones for the ZDC modules. The screening will be done by January 99, a couple of students from the University of Maryland will help with this project
- ∃ it may be necessary to get bases for the RCA tubes, this may be done at the UMD.

ZCAL-RHIC Interface

- What does RHIC plan to do with the ZCAL ?
- HV control
 - The power supply
 - Location and cabling
- Readout/Interface scheme
 - The scaler
 - Location and cabling
- Summary

What does RHIC want to do with it?

- RHIC uses ZCAL while experiments are OFF!
- test run, March 99
 - at least one module at BRAHMS
 - set up readout electronics (NIM)
 - test control software and application
 - monitor backgrounds (single beam)
- commissioning run, June/July 99
 - all IRs equipped
 - adjust readout electronics (coincidence)
 - understand/measure single beam backgrounds
 - understand/measure collision rate at IRs
- physics run, start Nov. 99
 - tune IR (before data taking)
 - monitor rates while exp. taking data
- any machine study periods later:
 - transverse/longitudinal beam-beam scans
 - background/luminosity related studies
- ➔ requirements for RHIC: measure relative luminosity!

HV control

- 4 BiRa control board: VME 4877PS
 - 6 independent channels (3.5 kV, 2.5 mA) per module
 - external interlock
 - PS residing in separated VME mini chassis
 - total cost: \$17,400 + \$8,000 (for mini VME)
- location:
 - BRAHMS: experimental counting room (trailer)
 - STAR: service building (1006 B)
 - PHENIX: service building (1008 B)
 - PHOBOS: experimental counting room (trailer)
- cabling (SHV cables) done by:
 - BRAHMS & PHOBOS: experiment
 - STAR & PHENIX: RHIC
- controls software:
 - FE software: started
 - application software: 1. draft available
- calibration: experiments

zztry

RHIC LumMon Control

File Scaling Graphs Attributes Delete Add

ZCAI on/off: on

PS status: on

HV.Lchn1 1800

HV.Rchn1 2000

HV.Lchn2 2000

HV.Rchn2 2000

HV.Lchn3 2000

HV.Rchn3 2000

Scroll Plot

Long Term

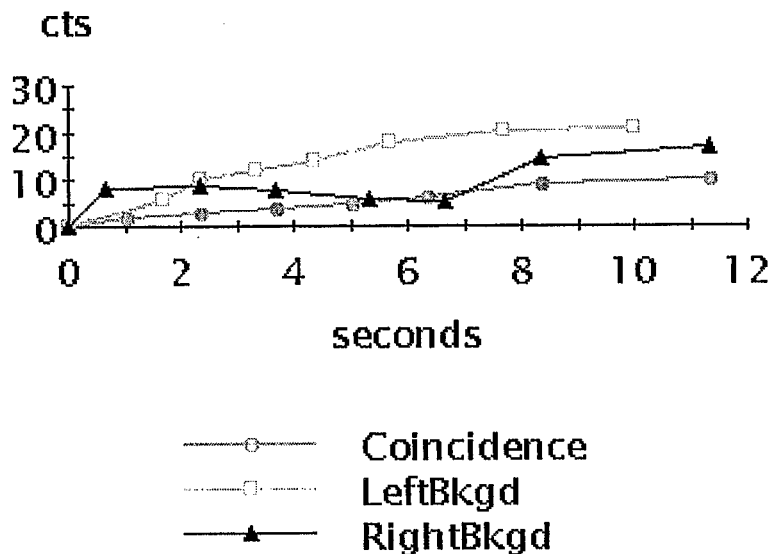
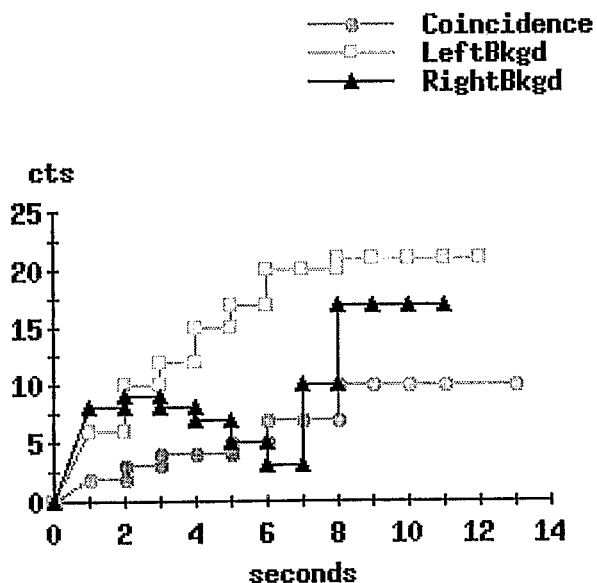

Reset Graph: axis labels set to seconds
Reset Graph: axis labels set to seconds

The Scaler

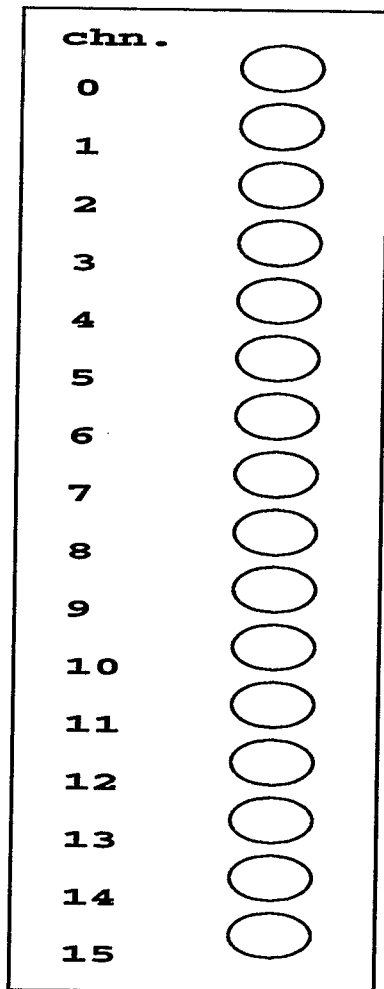

coincident rate
single rate (left)
single rate (right)
BBC (coincidence)
BBC (single left)
BBC (single right)

PIN diode #1
PIN diode #2
PIN diode #3
PIN diode #4
PIN diode #5
PIN diode #6
PIN diode #7
PIN diode #8

• hardware: 4 16-chn. NIM scalers already in hand

• software:

• FE software: started

• first draft application software available

BRAMS, PHENIX, PHOBOS

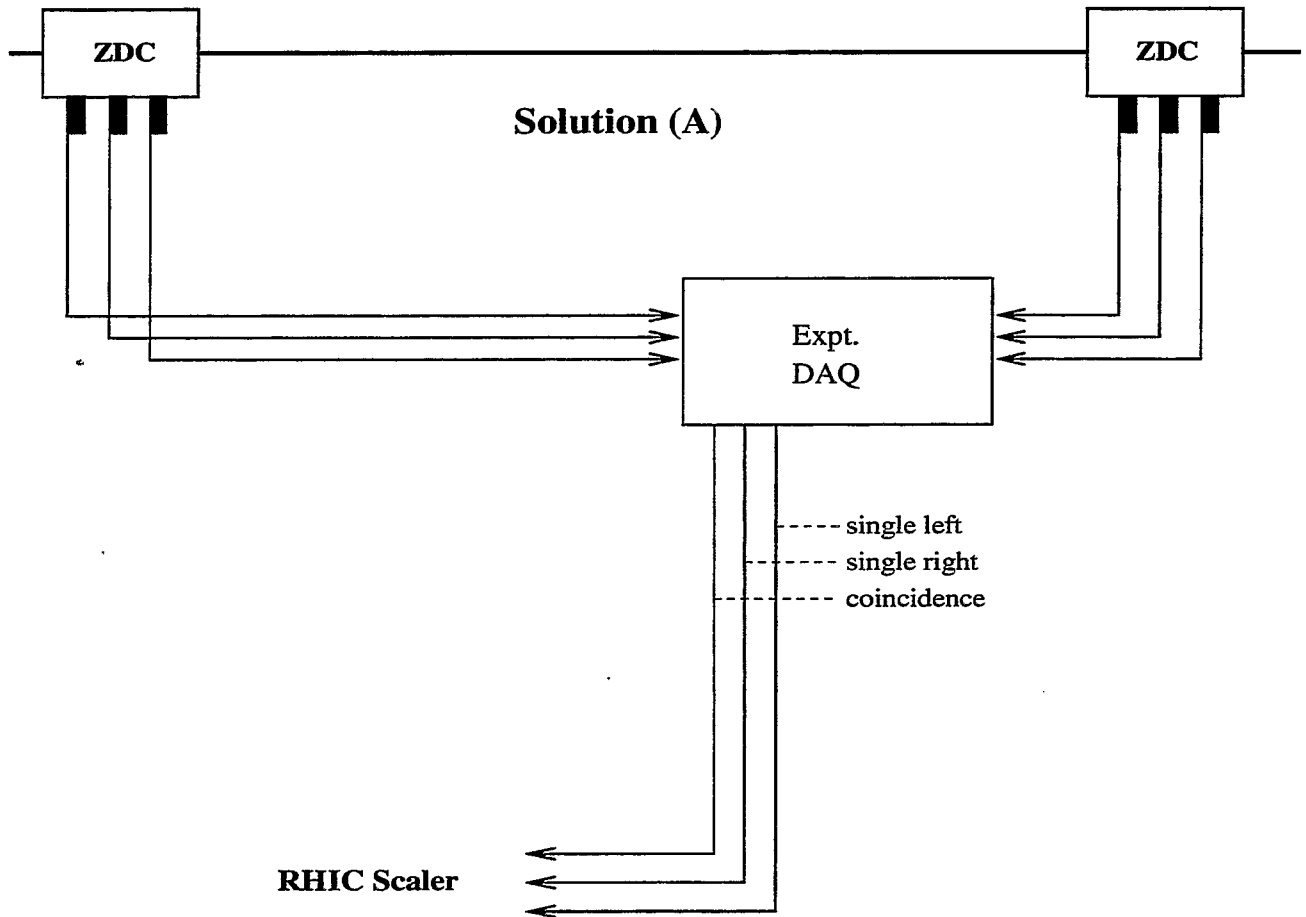

- experimental data acquisition provides logical signal as input to RHIC scaler at any requested time
- scaler to be in experimental counting rooms within RHIC controls VME crate
- cables pulled by experiments

STAR interface scheme

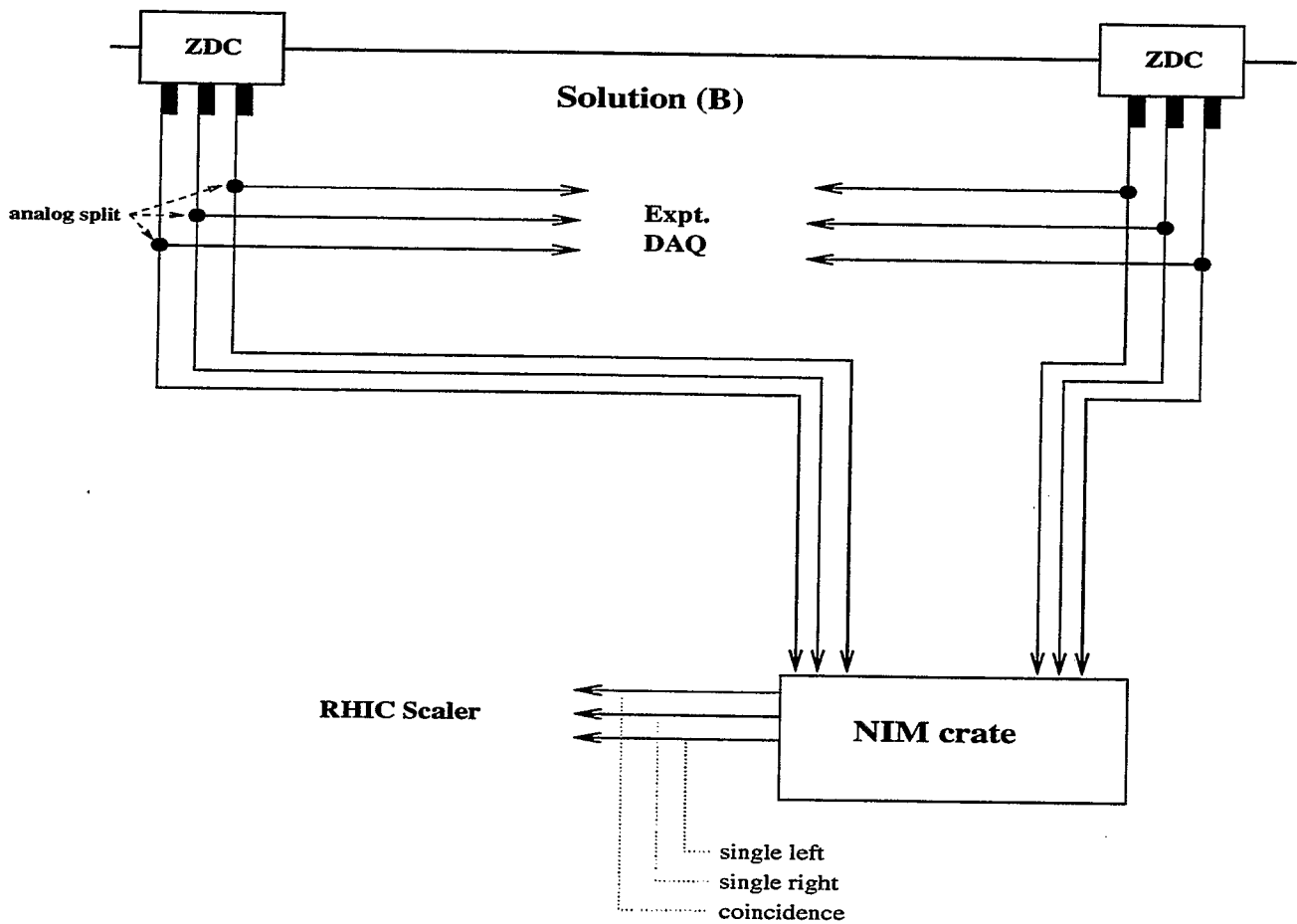

● scaler located in service building 1006 B

● cables will be pulled by RHIC

Summary

summary hardware locations:

Exp.	PS		scaler	
	location	cabling	location	cabling
BRAHMS	trailer	exp.	trailer	exp.
STAR	1006 B	RHIC	1006 B	RHIC
PHENIX	1008 B	RHIC	ctrl. room	exp.
PHOBOS	trailer	exp.	trailer	exp.

open questions:

- analog split for STAR
- STAR scaler really in service building?
- communication protocol to be defined



Minutes of the RHIC Experiment Safety Subcommittee meeting
October 2, 1998

Subject: The zero degree calorimeters

Present: A. Etkin, Y. Makdisi, S. Musolino

A. Drees, E. Garcia, G. McIntyre, W. MacKay, W. Murray, S. White

Each Zero Degree Calorimeter consists of three compact detectors made from interleaved layers of tungsten and scintillator. The light is carried by fibers optics to a photo tube mounted on top of each unit. Two calorimeters will be installed on either side of an intersection region in the location between the beam pipes between the DX and D0 magnets.

Each calorimeter section weighs approximately 50 kg. Lifting eyes were installed and tested to 135 kg and the analysis determined that the lifting eyebolts may fail at approximately 200 kg.

- The lifting eyes should be certified prior to installation at BNL.
- The MSDS for all material will be provided to the Safety Committee.

A low flow of dry nitrogen gas may be circulated in the detectors to retard radiation damage. This is not perceived to present a safety issue.

- Photo tube bases shall be tested to twice the operating voltage + 1000 Volts.
- The cabling, high voltage and signal, and connectors shall be procured consistent with the RHIC SEAPPM regarding color coding, tray and flame ratings and if possible separated inside the cable trays. It is recommended that the same cable be utilized in all intersection regions.

The readout electronics will utilize commercial VME crates and power supplies, the details of which were not presented.

- All exposed high current busses should be covered.

cc:

L. DeBobes	T. Ludlam	S. Ozaki
D. Lowenstein	M. Murtagh	File