



BNL-99352-2013-TECH

C-A/AP/201;BNL-99352-2013-IR

Numerical Simulation on Nitrogen Migration and ODH in RHIC Tunnel

L. Jia

May 2005

Collider Accelerator Department
Brookhaven National Laboratory

U.S. Department of Energy

USDOE Office of Science (SC)

Notice: This technical note has been authored by employees of Brookhaven Science Associates, LLC under Contract No. DE-AC02-98CH10886 with the U.S. Department of Energy. The publisher by accepting the technical note for publication acknowledges that the United States Government retains a non-exclusive, paid-up, irrevocable, world-wide license to publish or reproduce the published form of this technical note, or allow others to do so, for United States Government purposes.

DISCLAIMER

This report was prepared as an account of work sponsored by an agency of the United States Government. Neither the United States Government nor any agency thereof, nor any of their employees, nor any of their contractors, subcontractors, or their employees, makes any warranty, express or implied, or assumes any legal liability or responsibility for the accuracy, completeness, or any third party's use or the results of such use of any information, apparatus, product, or process disclosed, or represents that its use would not infringe privately owned rights. Reference herein to any specific commercial product, process, or service by trade name, trademark, manufacturer, or otherwise, does not necessarily constitute or imply its endorsement, recommendation, or favoring by the United States Government or any agency thereof or its contractors or subcontractors. The views and opinions of authors expressed herein do not necessarily state or reflect those of the United States Government or any agency thereof.

C-A/AP/#201
May 2005

Numerical Simulation on Nitrogen Migration and ODH in RHIC Tunnel

L. Jia



**Collider-Accelerator Department
Brookhaven National Laboratory
Upton, NY 11973**

Numerical Simulation
on
Nitrogen Migration and ODH in RHIC Tunnel

Lin Xiang Jia

February, 2005

Collider-Accelerator Department
Brookhaven National Laboratory
Upton, NY 11973

Introduction

An investigation by numerical simulation to reveal possible oxygen deficiency hazards caused by controlled and uncontrolled release of nitrogen purge gas into the RHIC tunnel was initiated by the Accelerator Systems Safety Review Committee (See Appendixes).

A computational fluid dynamics package, FLUENT, was used to carry out the numerical simulation on mole fraction of oxygen in the tunnel by means of three dimensional and transient. This report presents the simulation results by providing the data in contour and profile plots in space and time.

The species modeled include only oxygen and nitrogen, no other chemical species are considered. A multiple species mass transfer model with effects of gravity acceleration is applied. The Fick's law is used to model diffusion of chemical species in turbulent flows as:

$$J_i = -(\rho D_{i,m} + \mu_i / Sc_i) \nabla Y_i - D_{T,i} \nabla T / T$$

Where $D_{i,m}$ is the mass diffusion coefficient for species i in the mixture in laminar flow and $D_{T,i}$ is the thermal diffusion coefficient, Sc_i is the effective Schmidt number for the turbulent flow.

The physical model of RHIC tunnel is determined by taking the information provided in Appendixes, which is somewhat simplified according to the limitation of the numerical package and the knowledge of author as well.

The work is divided in a fashion of five study CASES in order to emphasize the focus and to deal with the problem under different initial and boundary conditions. For each CASE, the physical model is illustrated in a schematic depicting the cross section and a length of one sextant. Only one sextant is modeled. A brief description for each CASE is also provided for flow arrangement with the space and time information.

In the first part of the simulation, the curvature of the tunnel was taken into account, which was found later that some post processing advantages were sacrificed in different coordinate system. In later part, the tunnel was treated as straight and only half of the tunnel was modeled for its symmetry. The difference of the curved or straight tunnel modeled has been proved trivial. Results by both methods are presented in the report.

For the CASE of "squirrel-cage" and "elephant trunk" in the last section, section 5, of this report provides some discussions in detail for the effect of two different discharging directions.

The author thanks Woody Gleen and Gary McIntyre for providing the necessary information helping to complete this work.

CASE I

- (1) One curvature sextant of tunnel is modeled.
- (2) No blowing fan and no leaking out in the sextant.
- (3) At time=0, the tunnel is full of air (20.946% O₂+78.084% N₂ by Mole or 23.2%+75.5% by Mass).
- (4) At time>0, gaseous N₂ at 5.4g/s (10CFM) at room temperature (300K) is discharging into the tunnel at a spot somewhere near the center of sextant.
- (5) Geometry model is shown in following figure. A coordinate system is shown in the figure.

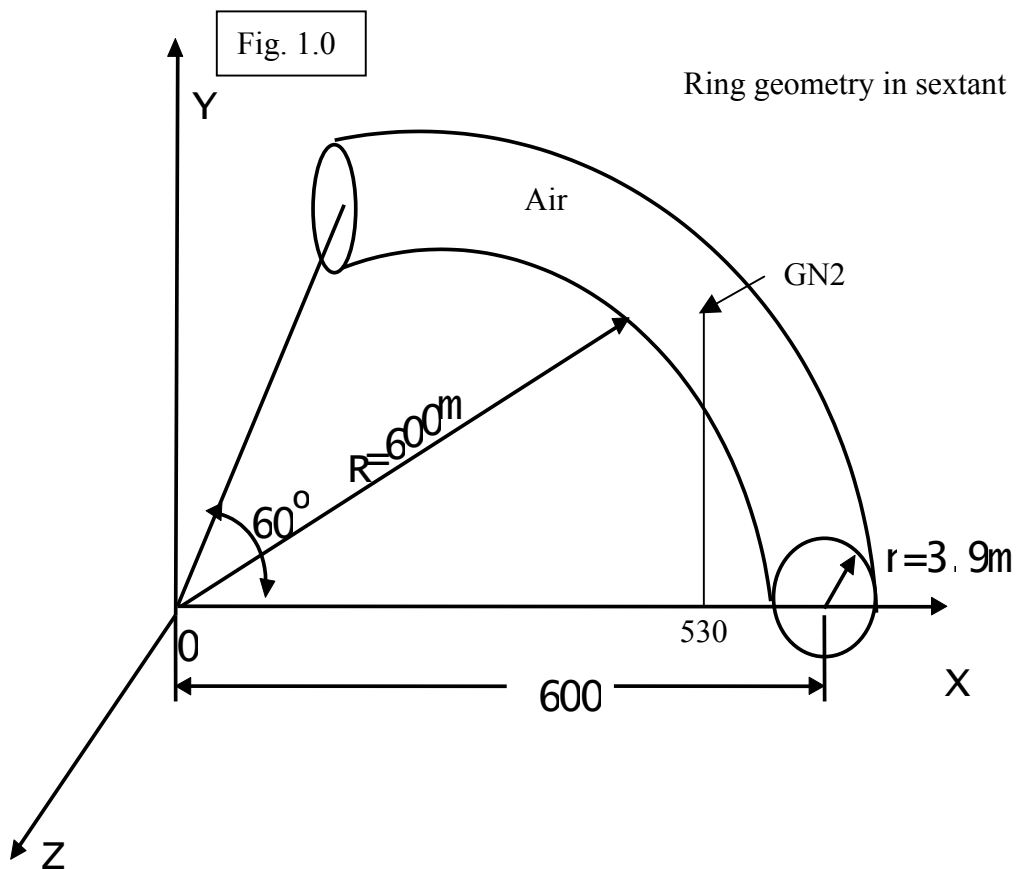

1.1 Contour of mole fraction of O₂ at t=65s. Nitrogen is symmetrically diffusing along the tunnel. The lowest oxygen concentration is higher than 19.4%.

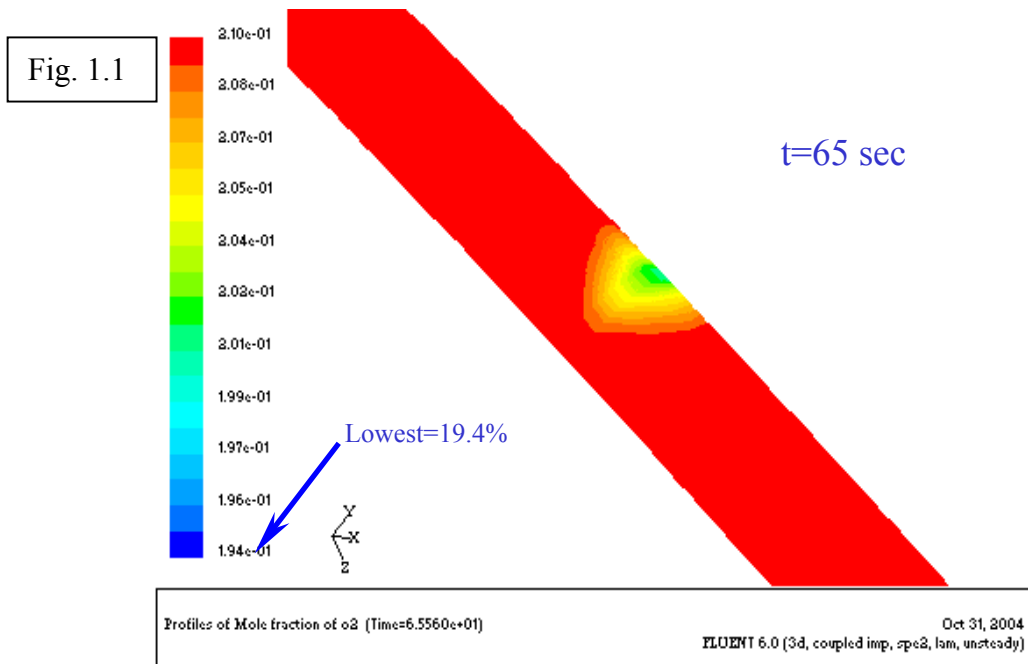

1.2 Contour of mole fraction of O₂ at t=648s. Nitrogen is symmetrically diffusing along the tunnel. The lowest oxygen concentration is still higher than 19.4%, slightly dropped in a small fraction of percentage, not shown in the color bar.

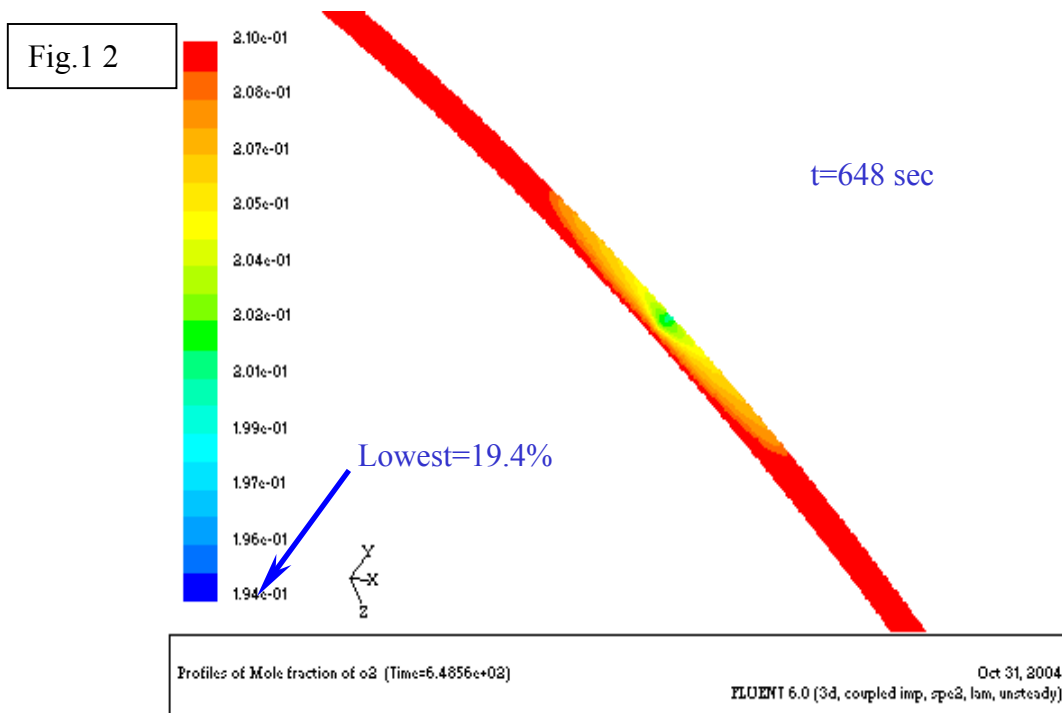

1.3 Contour of mass fraction of O₂ at x=530m (near discharging point) at t=648s. The cutting plan is elliptic shape and off centered, because it is parallel to x direction.

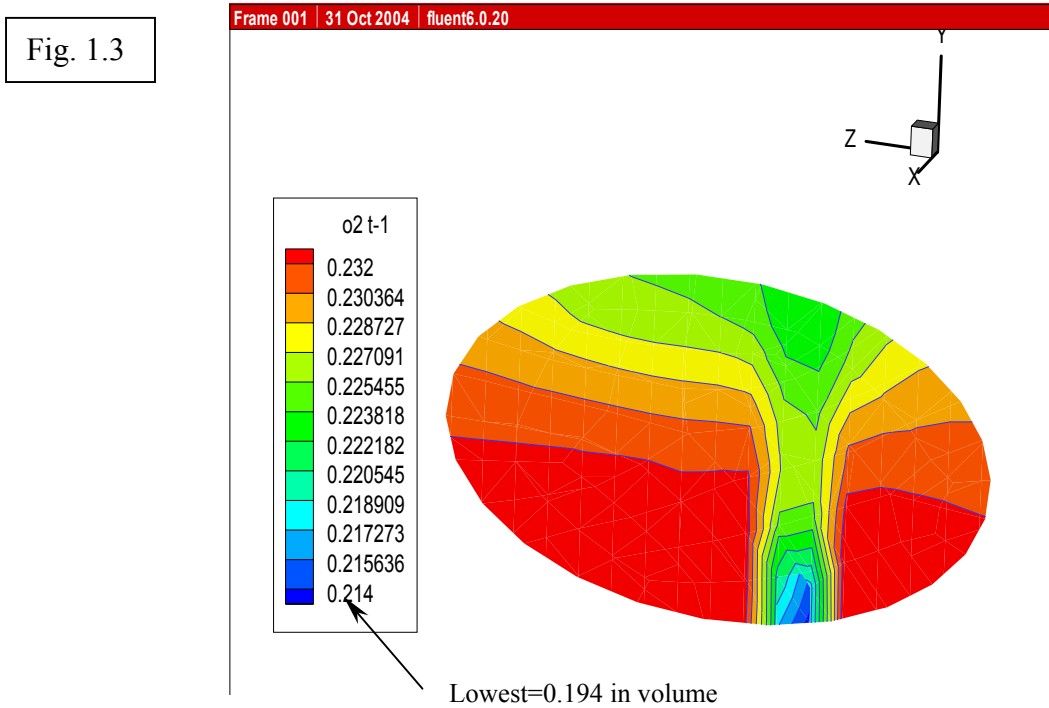

1.4 Mole fraction of O₂ at different height of tunnel along x direction at t=648s. Setting y=0 at bottom of tunnel, mole fractions of O₂ are given at y=0.5m (black), y=1.8m (red), y=7.8m (green), respectively, along z direction.

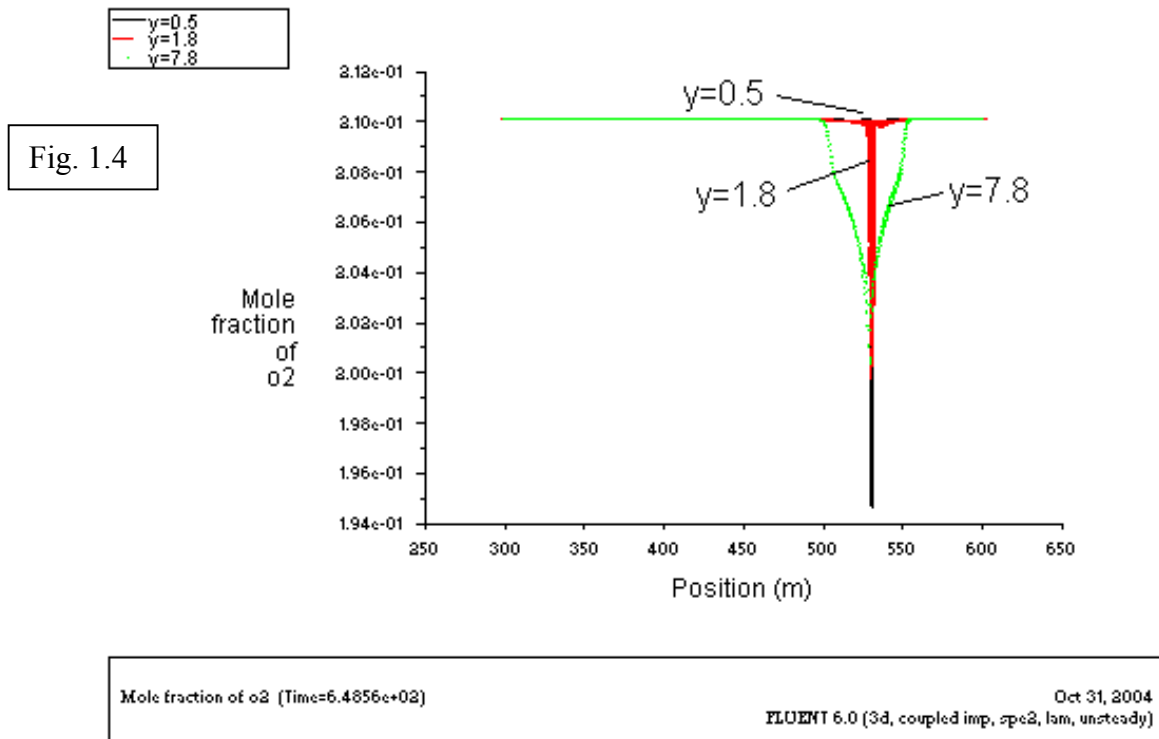

1.5 Mole fraction of O₂ at t=2948s. The lowest oxygen concentration is still higher than 19.4%.

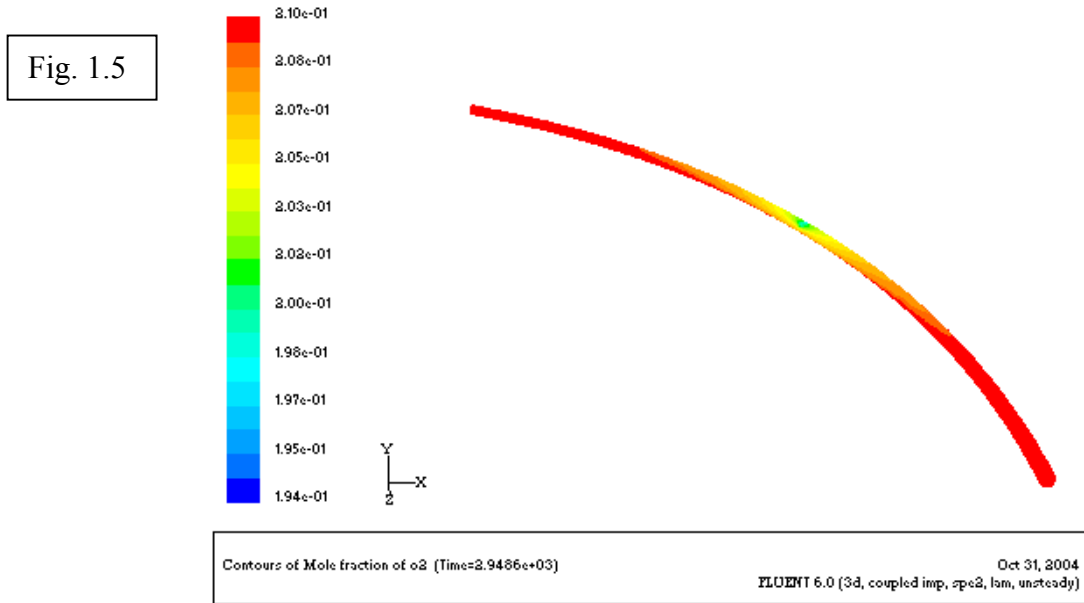

1.6 Mole fraction of O₂ at different heights of tunnel along x position at t=2948s.

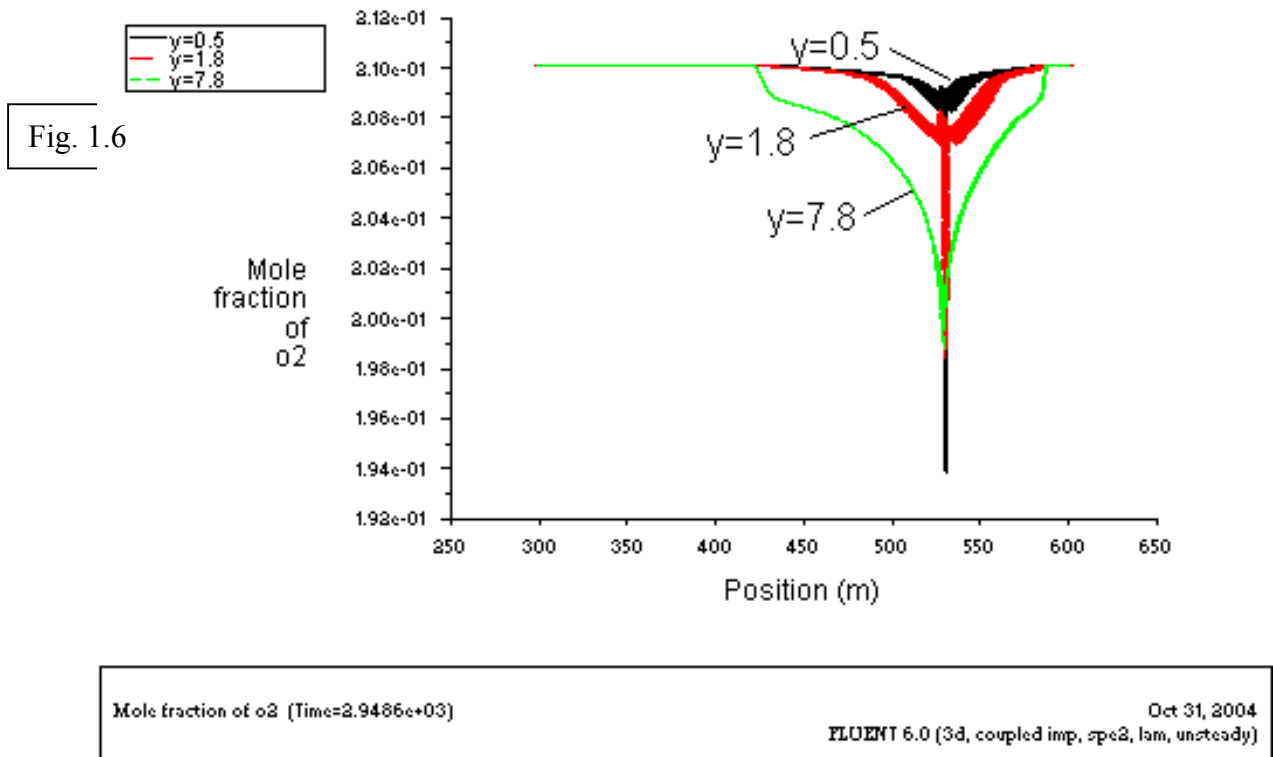

1.7 Mole fraction of O₂ at t=11949s (~200 minutes), The lowest O₂ concentration is higher than 18.9%.

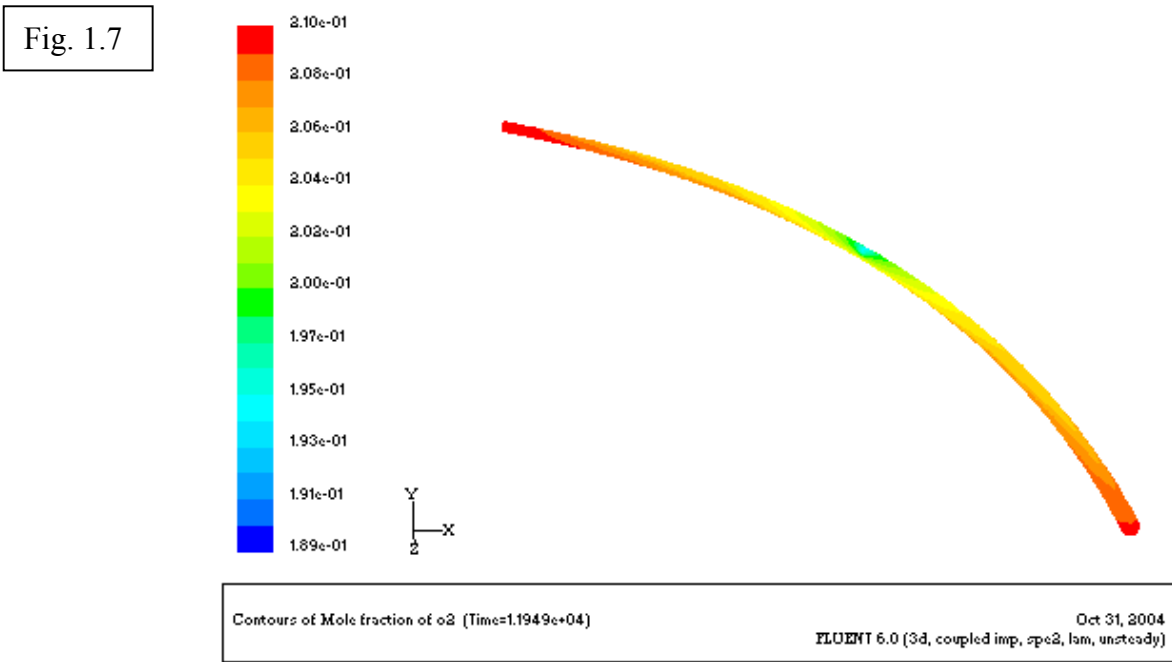

1.8 Mole fraction of O₂ at different height of tunnel along x direction, t=11949s (~200 minutes)

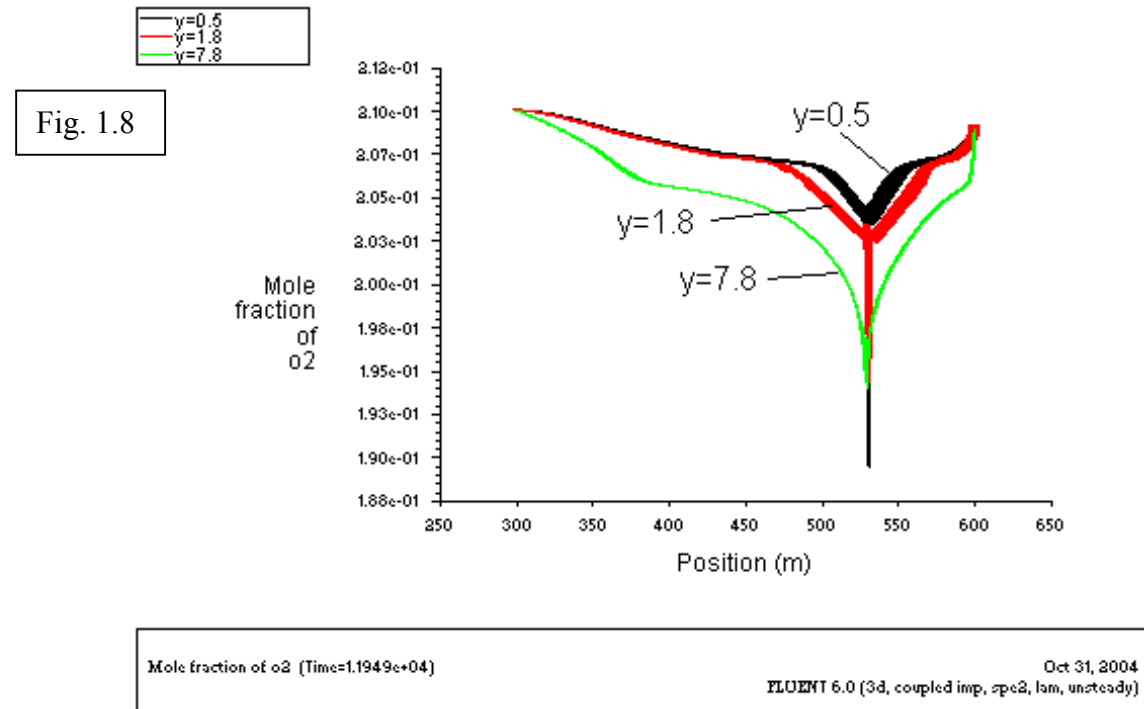

1.9 Contour of mass fraction of O2 at x=450m at t=48249s (~800min)

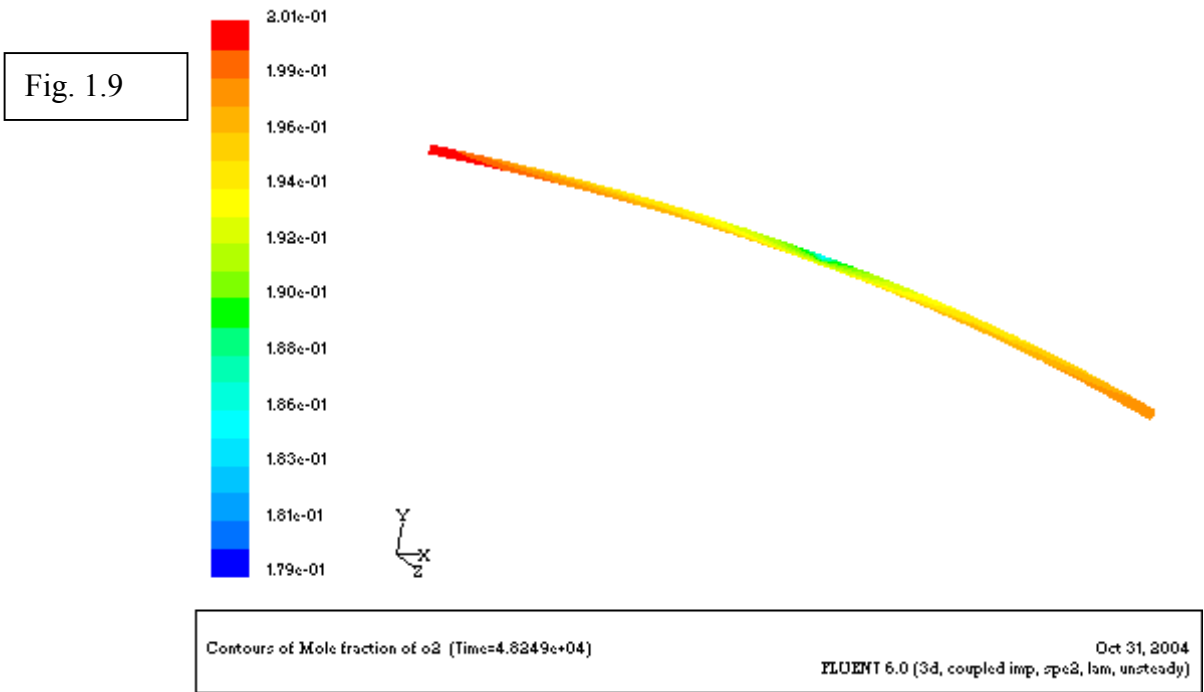

1.11 Contour of mass fraction of O2 at x=450m at t=48249s. The cutting plan is elliptic shape and off centered, because it is parallel to x direction.

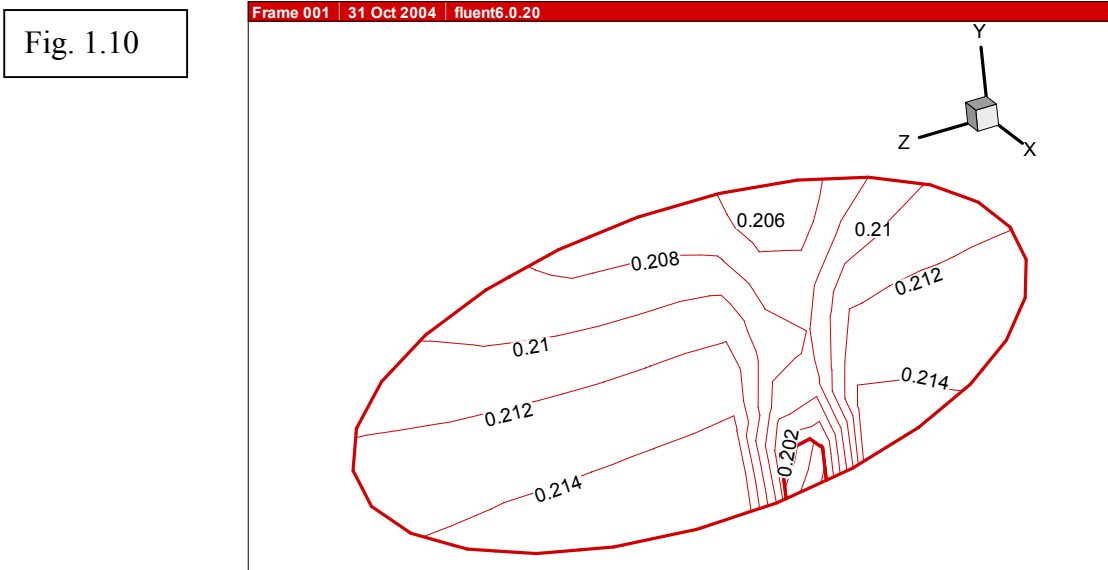

1.11 Mole fraction of O2 at different height of tunnel along x direction, t=48249s (~13 hrs)

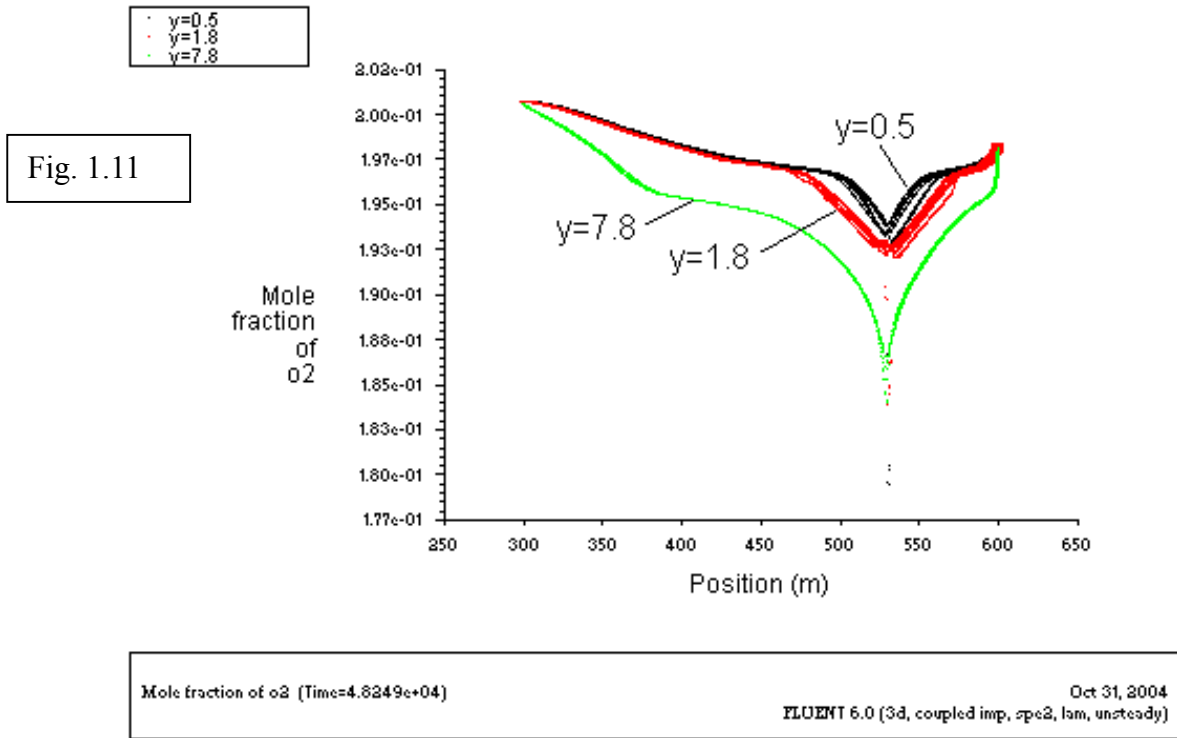

CASE II

Similar to CASE I except that the mixed gas is leaking out of the sextant at one end. The discharging point of GN2 is at $x=570\text{m}$ close to one end that is different from CASE I.

Fig. 2.0

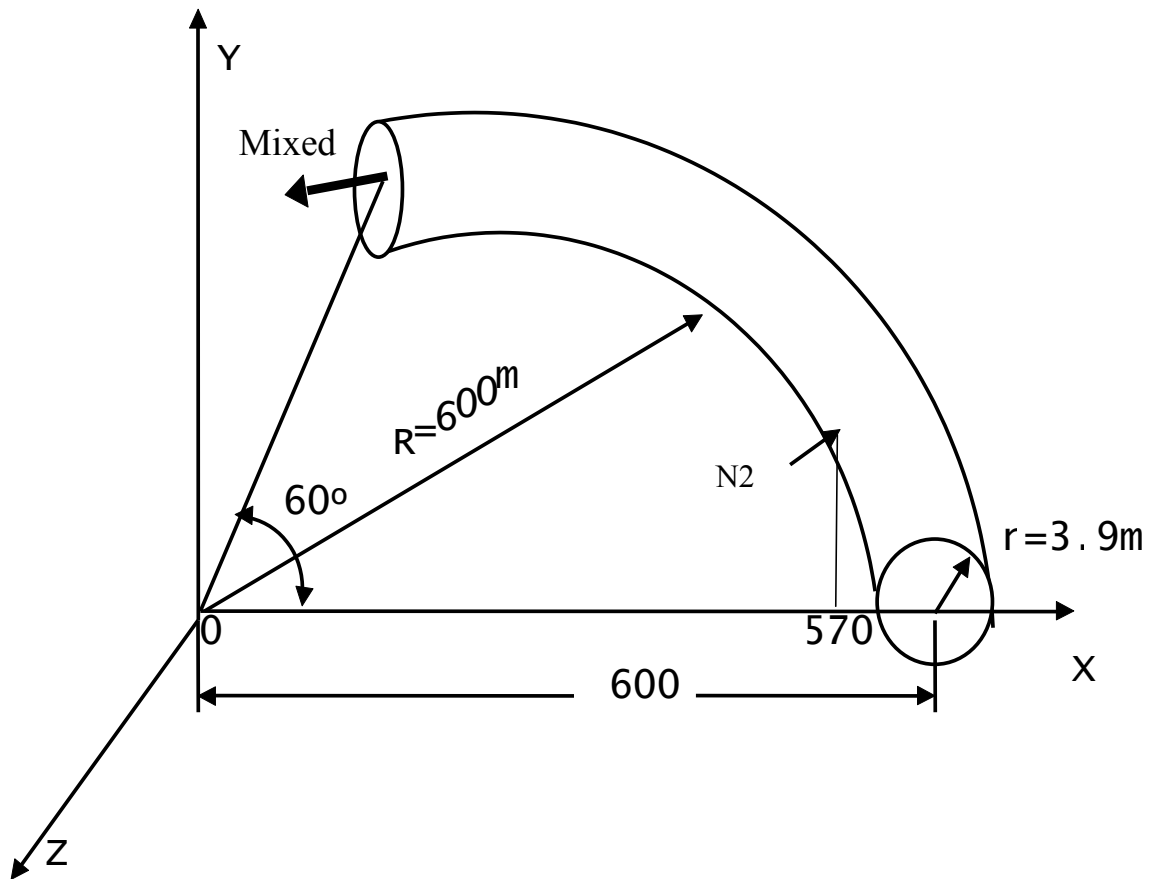

2.1 Mole fraction of O₂ at t=59s, the lowest O₂ concentration is higher than 17.7%.

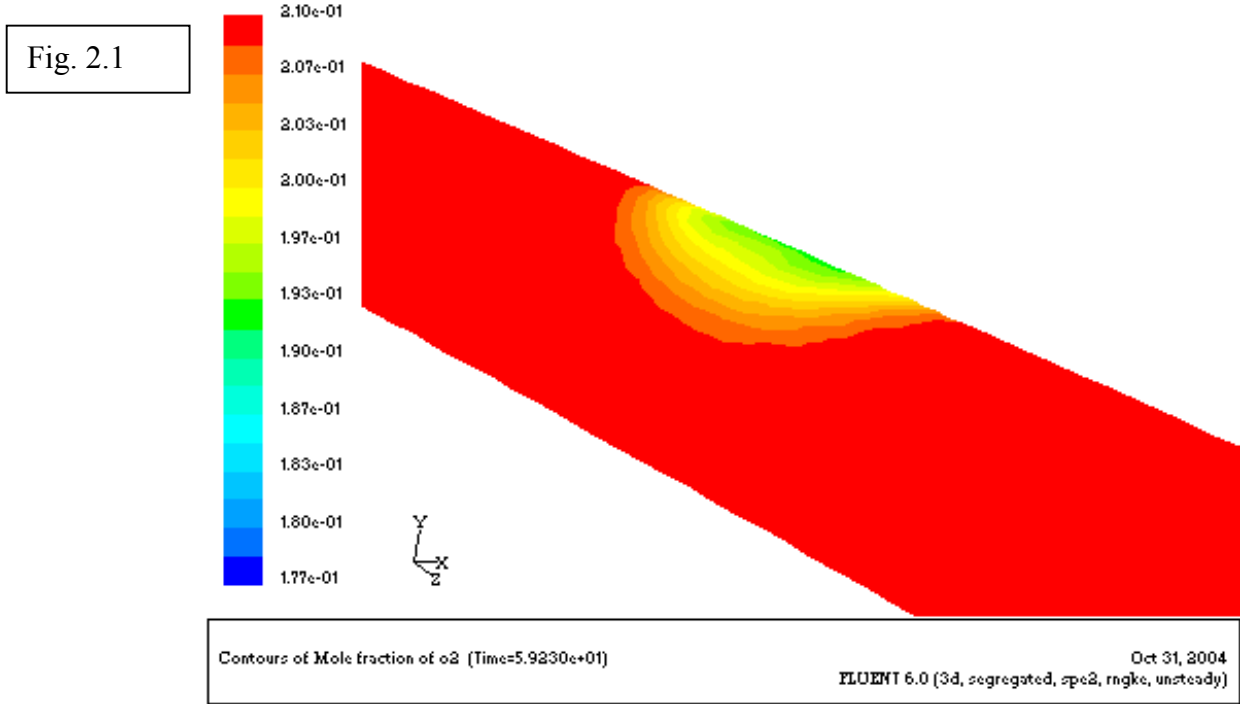

2.2 Mole fraction of O₂ at t=259s, the lowest O₂ concentration is still higher than 17.7% but in a large affected area.

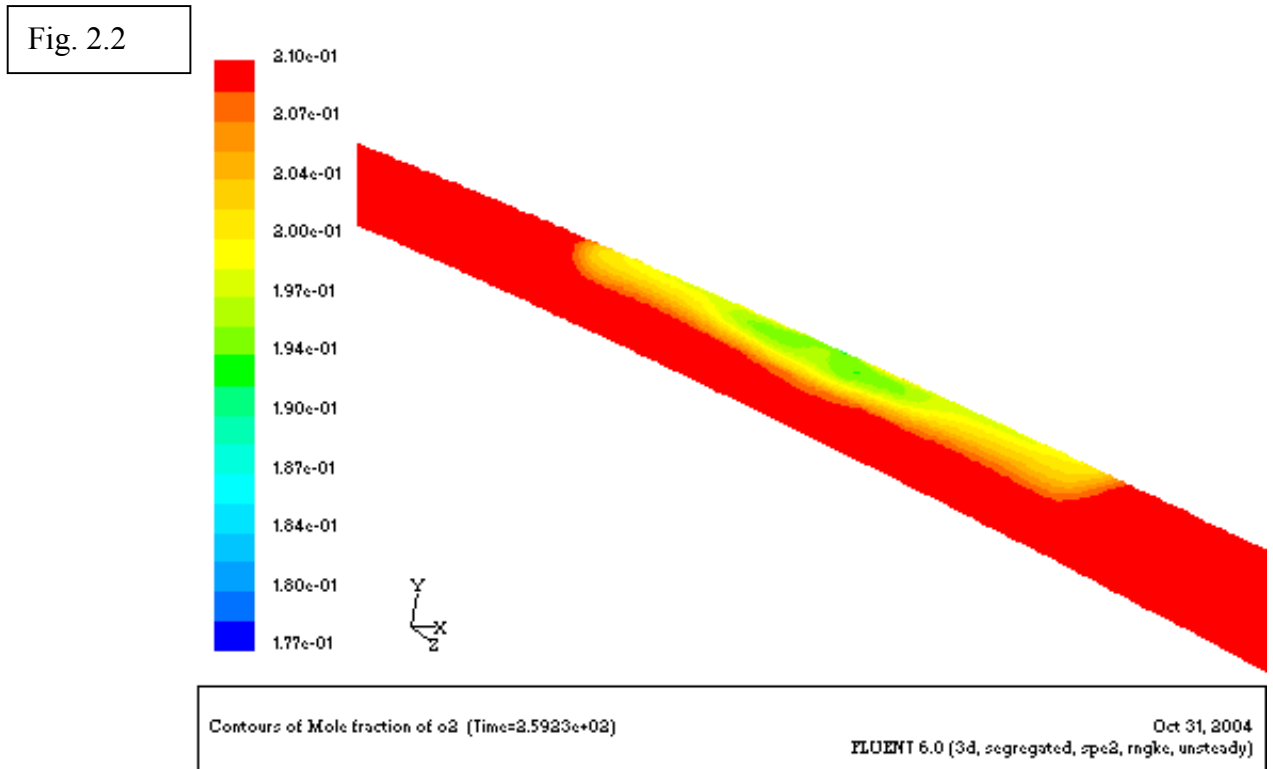

2.3 Mole fraction of O₂ at different heights of tunnel along x position. t=259s.

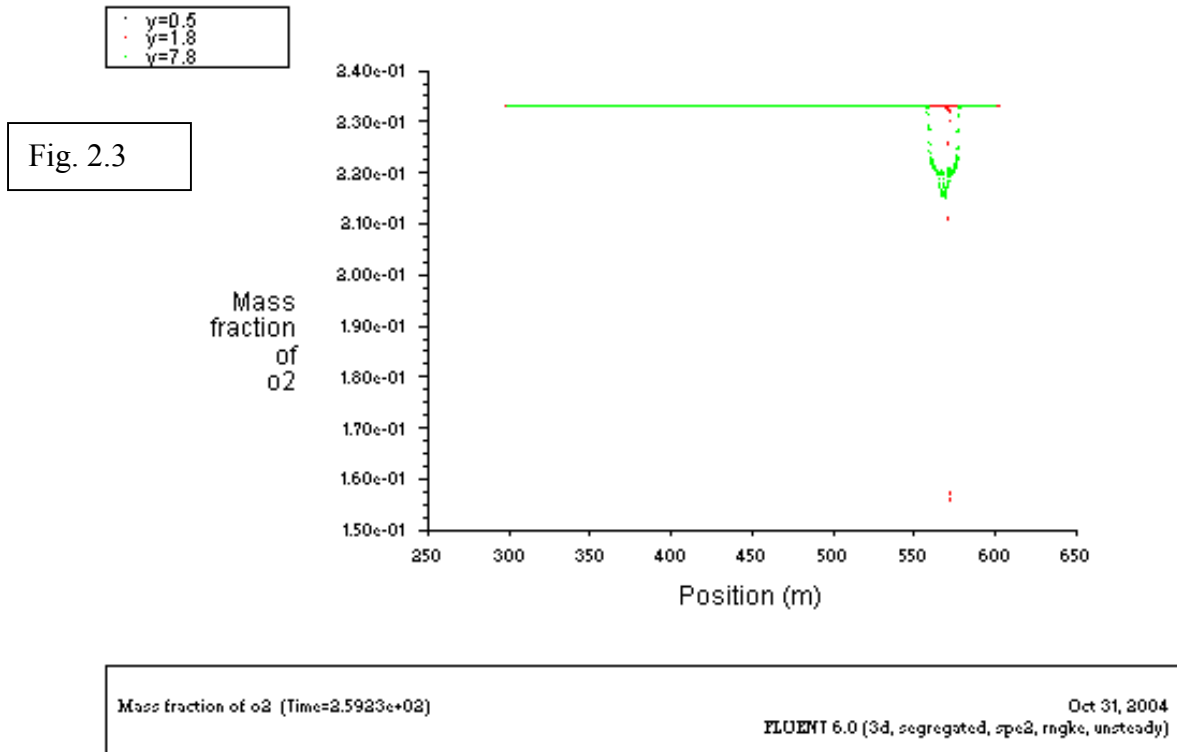

2.4 Mole fraction of O₂ at different heights of tunnel along x position. t=2159s.

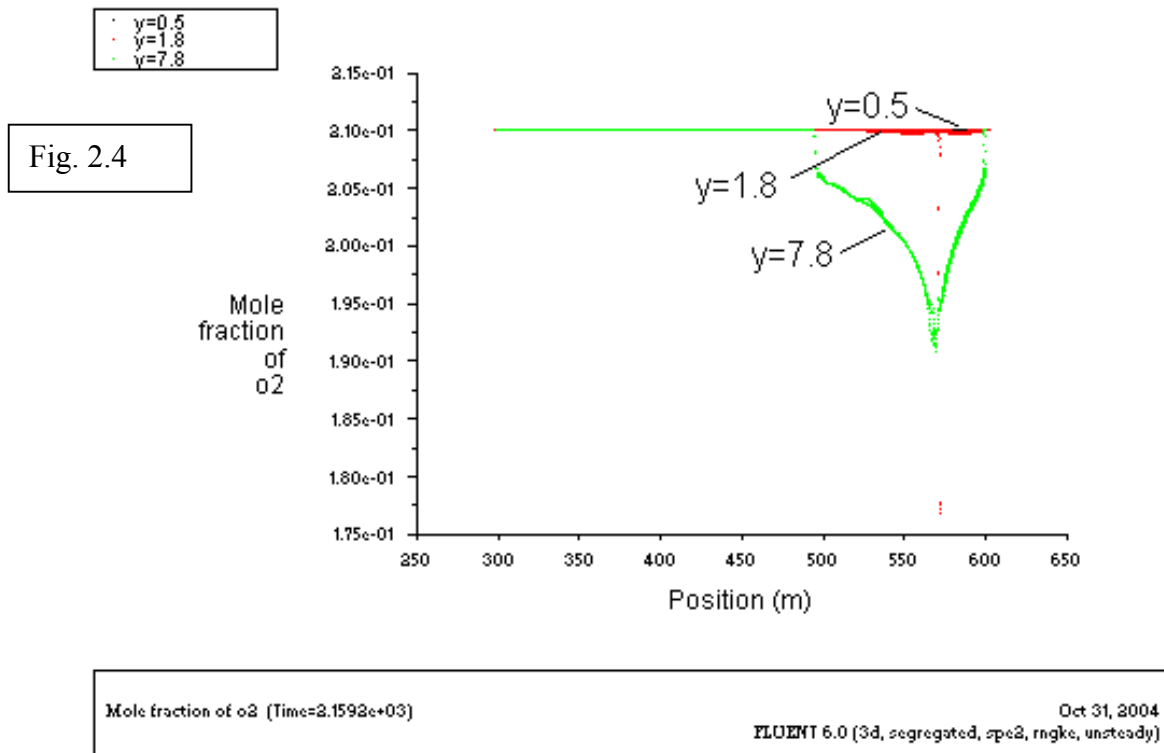

2.5 Mole fraction of O₂ at different heights of tunnel along x position. t=3989s.

· y=0.5
· y=1.8
· y=7.8

Fig. 2.5

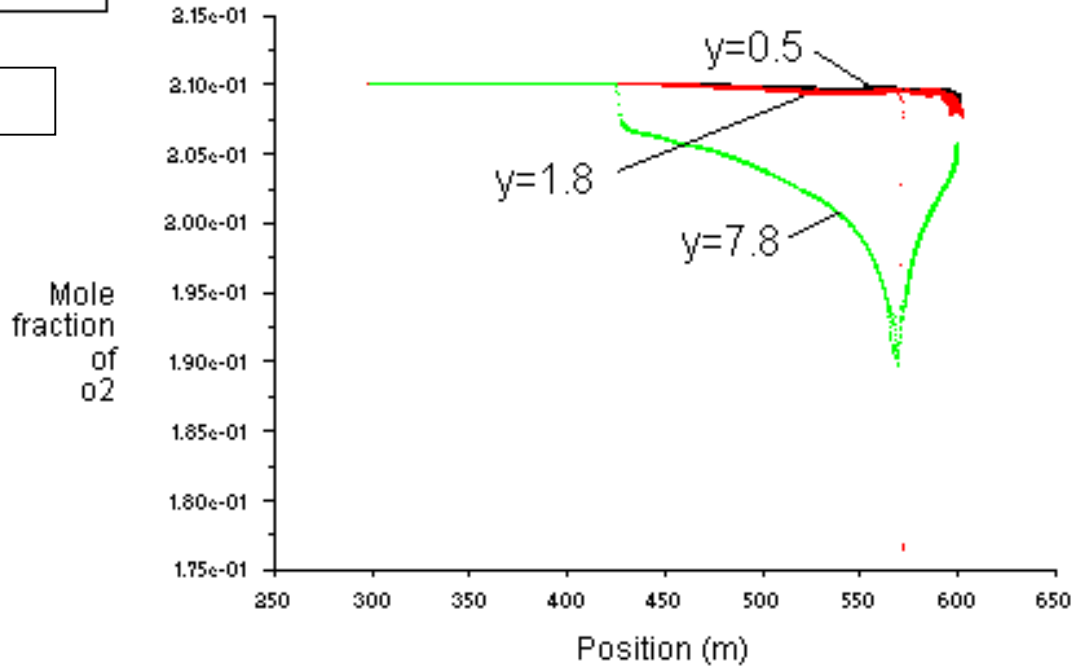

Mole fraction of o2 (Time=3.9892e+03) Oct 31, 2004
FLUENT 6.0 (3d, segregated, spe2, rngke, unsteady)

CASE III

The physical model is shown in Fig. 3.0, the curvature of the sextant is neglected. The GN2 at $z=10\text{m}$ is discharging into the sextant at flow rate of **10CFM**. An outlet is at the other end of the sextant, which keeps the pressure in sextant constant by discharging mixed gas out of the sextant at the same flow rate.

Fig. 3.0

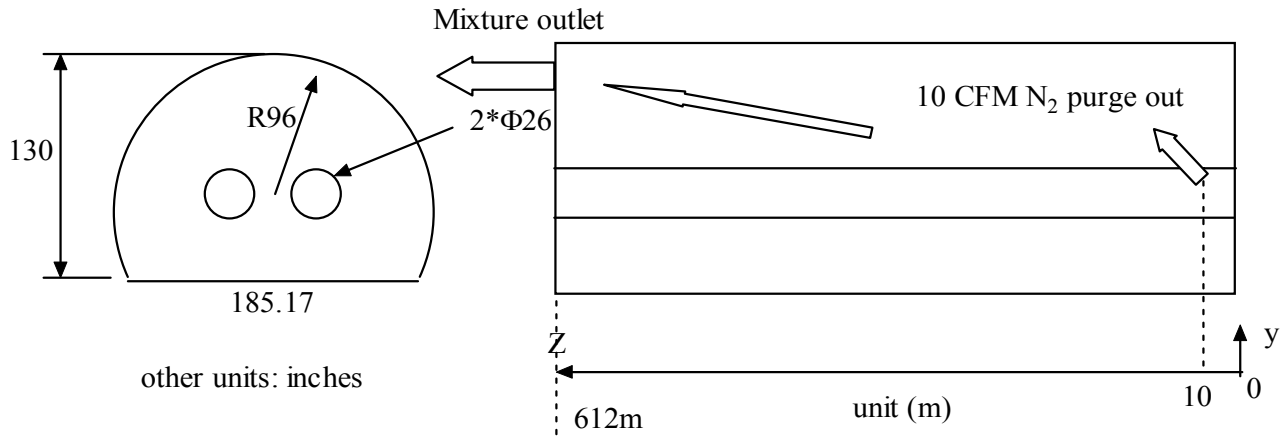

3.1 Mole fraction of O₂ at t=2619s, the lowest O₂ fraction is higher than 18.4%. The discharging point is at z=10m, where presents the lowest O₂ mole fraction. The discharging point is at the southeast side of the yellow ring at a view facing the cross section.

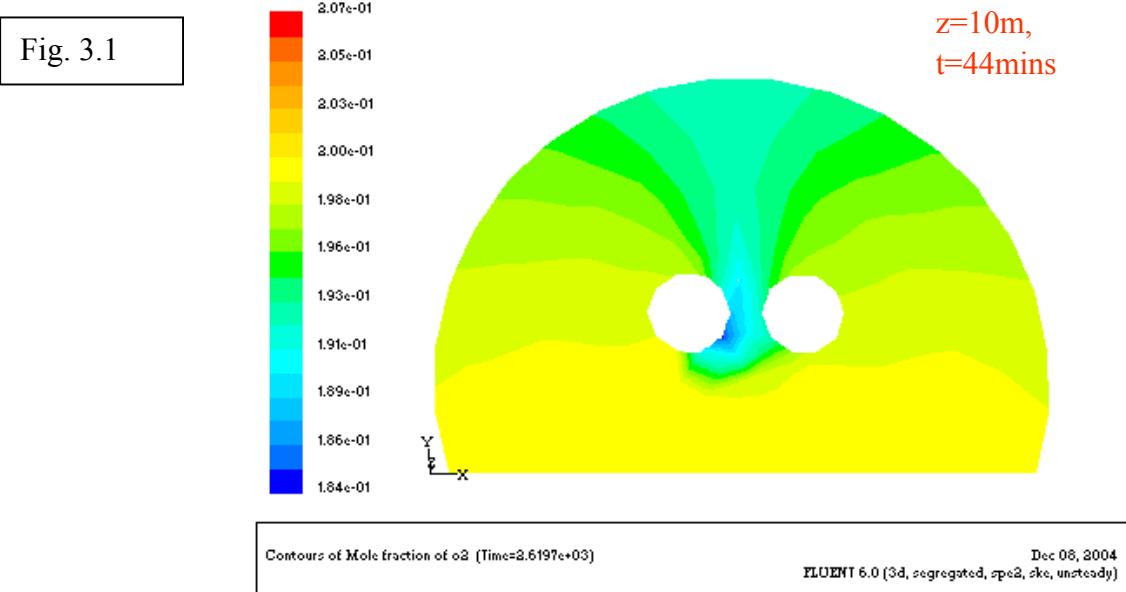

3.2 The O₂ mole fraction profile at a height of 1.8m above the ground of tunnel, along the axial direction of the sextant. It is 20.25% at t=860s and 19.75% at t=2620s. In a range between z=10m and z=40m along the tunnel (at y=1.8m), the O₂ level increases from 20.25% to normal air at t=860s. At t=2620s the lowest is 19.75% and extended to normal air at z=65m.

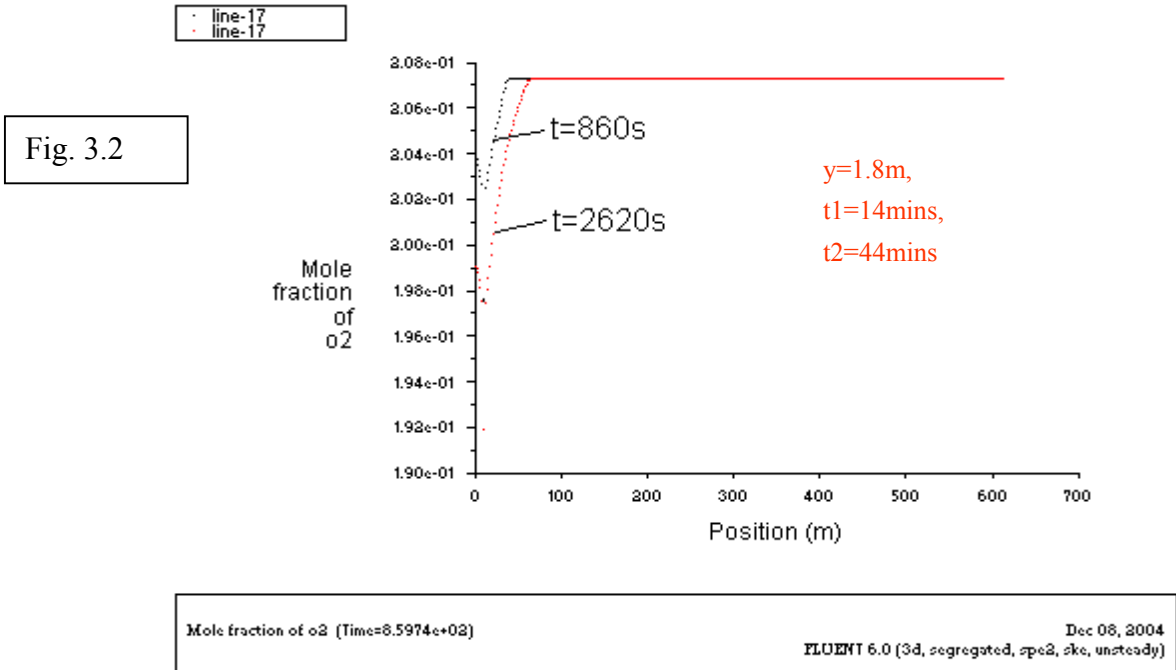

3.3 Mole fraction of O₂ at t=11510s, the lowest O₂ fraction is higher than 15.7%.

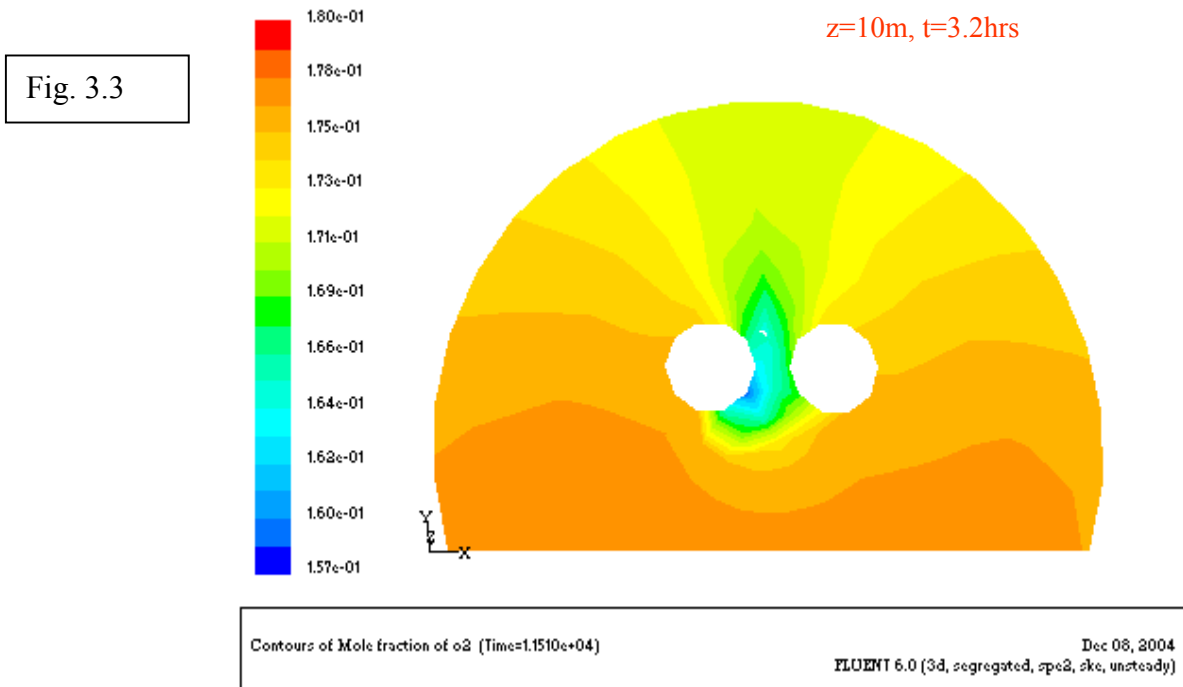

3.4 The O₂ mole fraction profile at a height of 1.8m above the ground of tunnel, along the axial direction of the sextant (z coordinate). The discharging point is at 10m in z direction, where presents the lowest O₂ mole fraction. In a range between z=10m and z=110m along the tunnel (at y=1.8m), the O₂ level increases from 18.5% to normal air at t=7270s. At t=11510s the lowest is 17.5% and extended to normal air at z=190m.

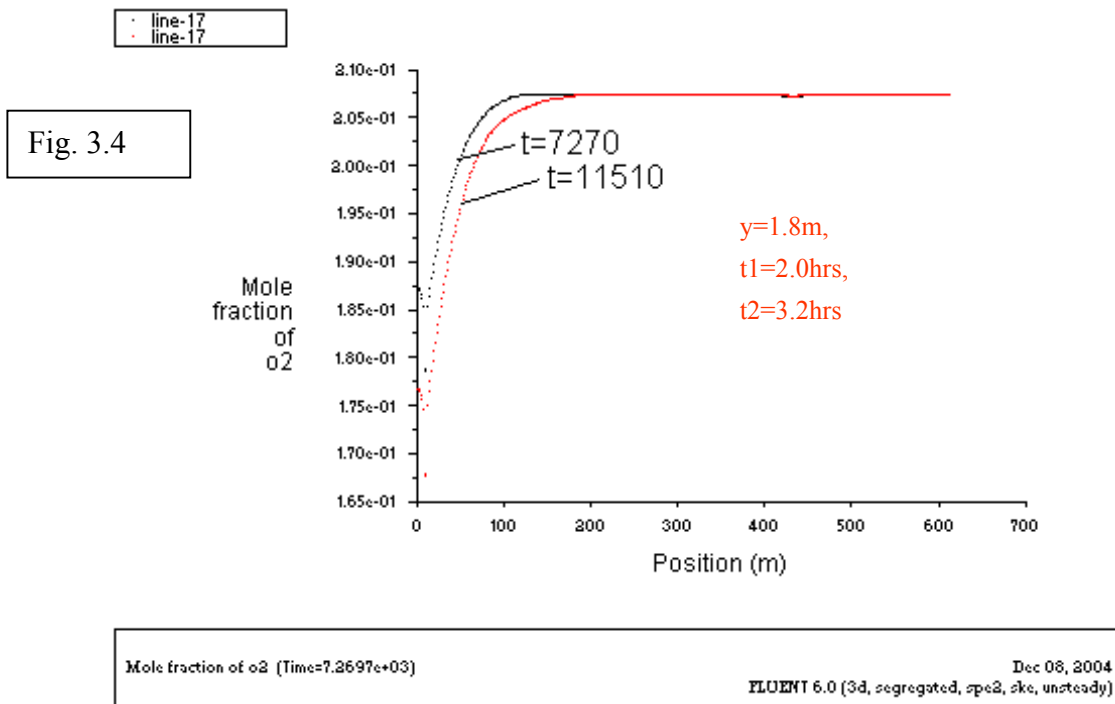

3.5 Contour of mole fraction of O2 at z=10m (discharging point) at t=16510s.

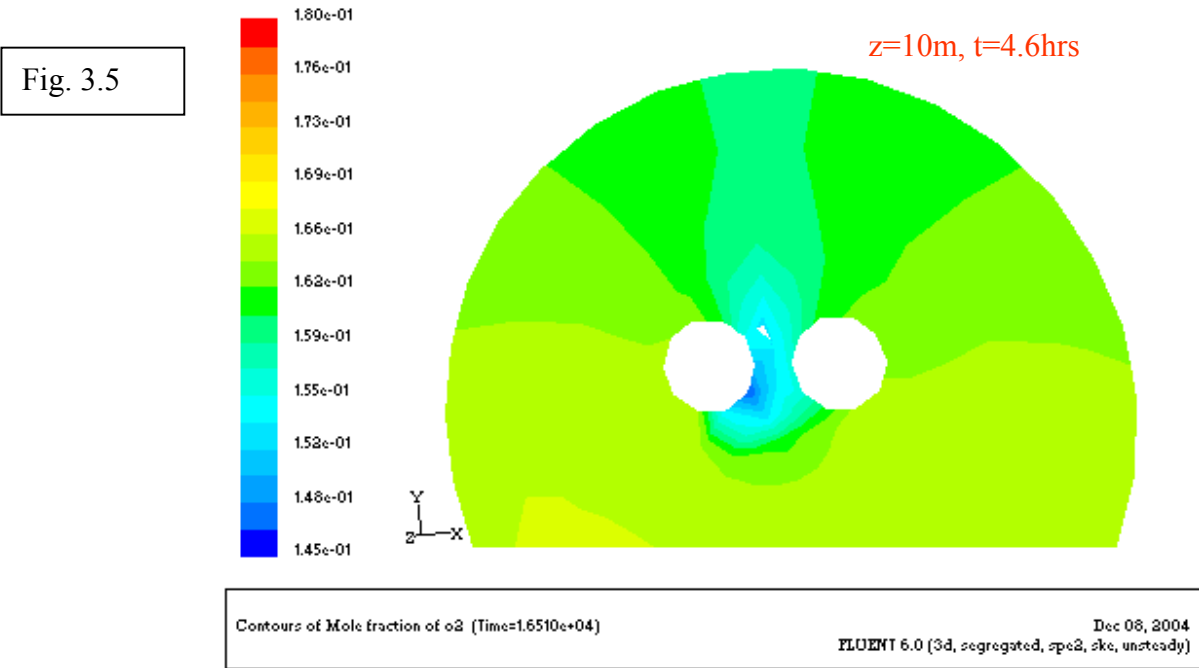

3.6 Contour of mole fraction of O2 at z=50m at t=16510s



3.7 The O₂ mole fraction profile at a height of 1.8m above the ground of tunnel, along the axial direction of the sextant (z coordinate).

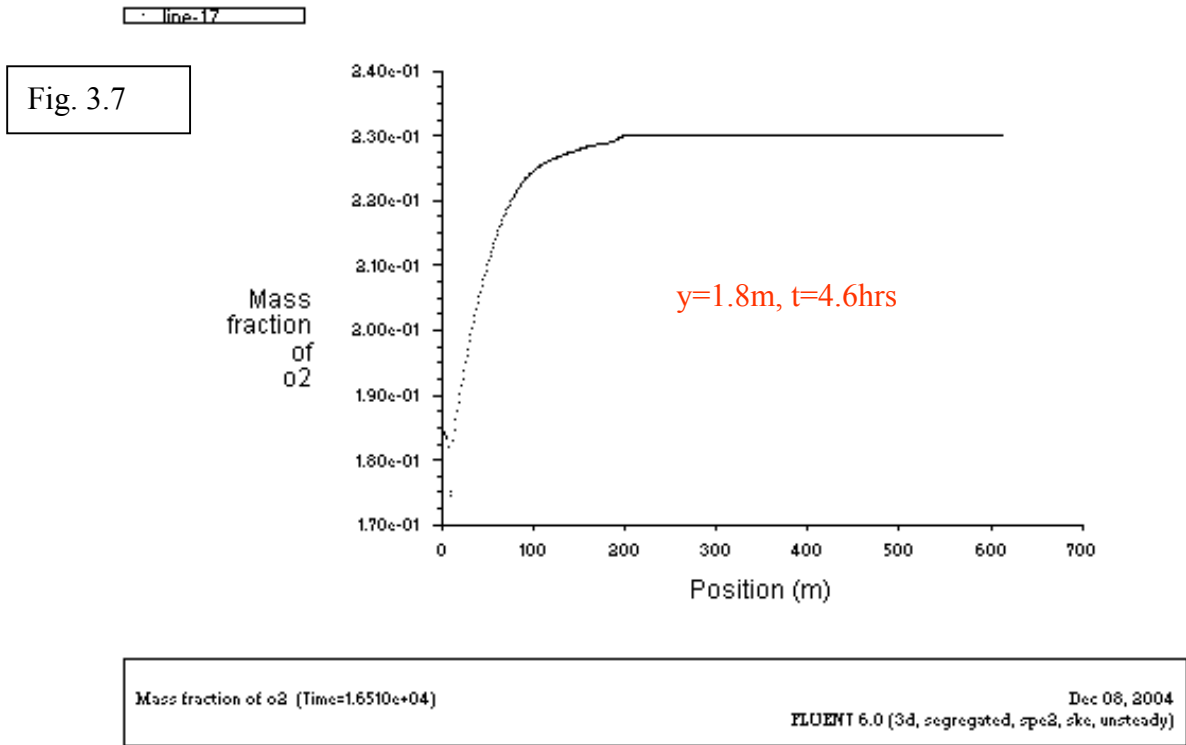

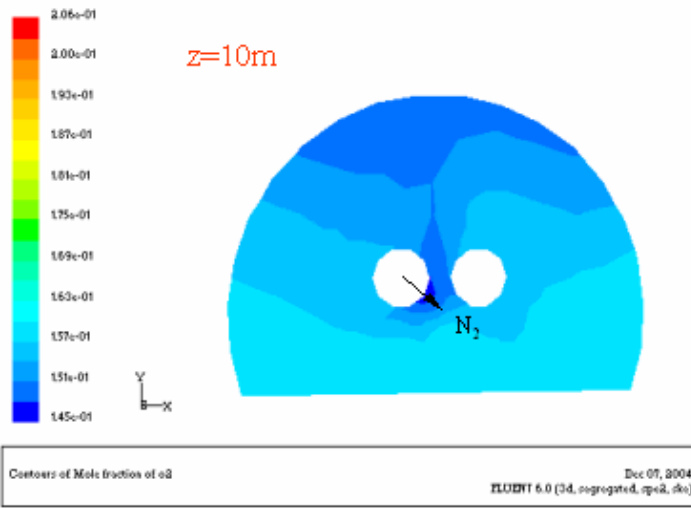

CASE IV

“Steady State”

70000s=19.4hrs

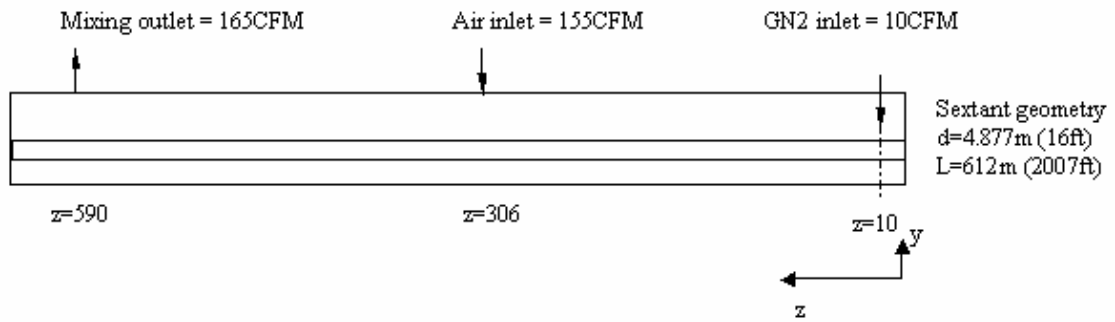

12-9-04

ODH in sextant with GN2 migration

1

4.2 Contour of mole fraction of O₂ at z=50m in steady state.

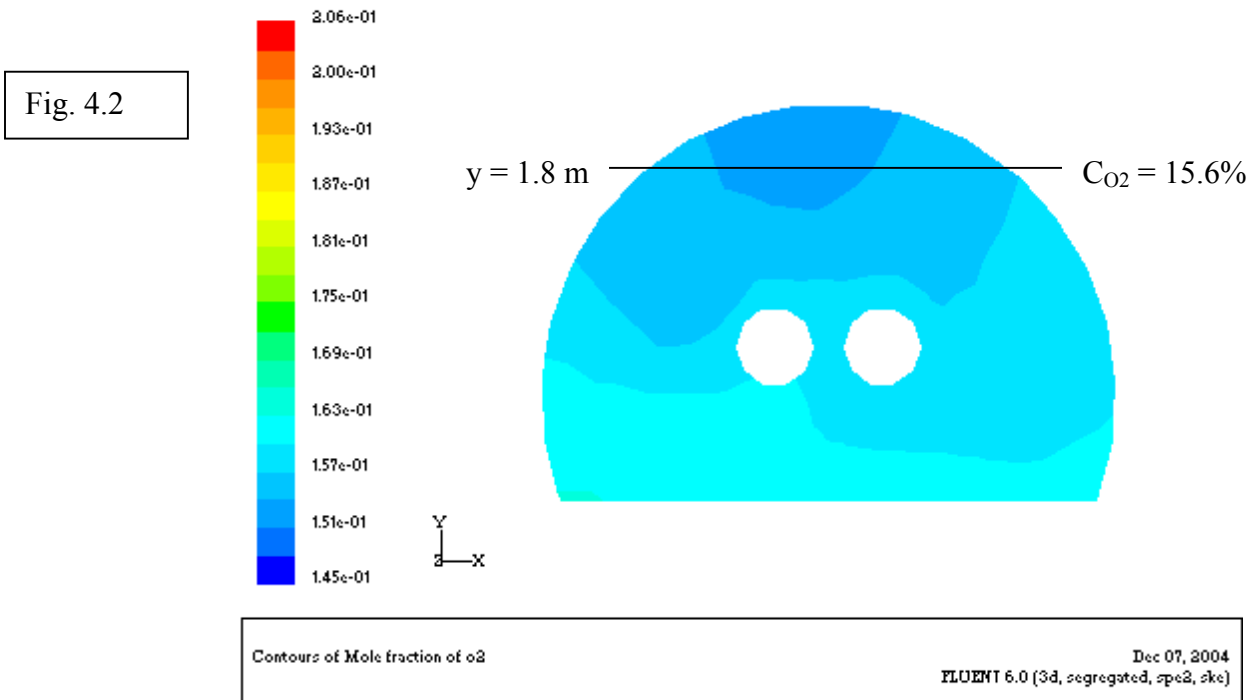

4.3 Profile of mole fraction of O₂ at y=1.8m along z direction

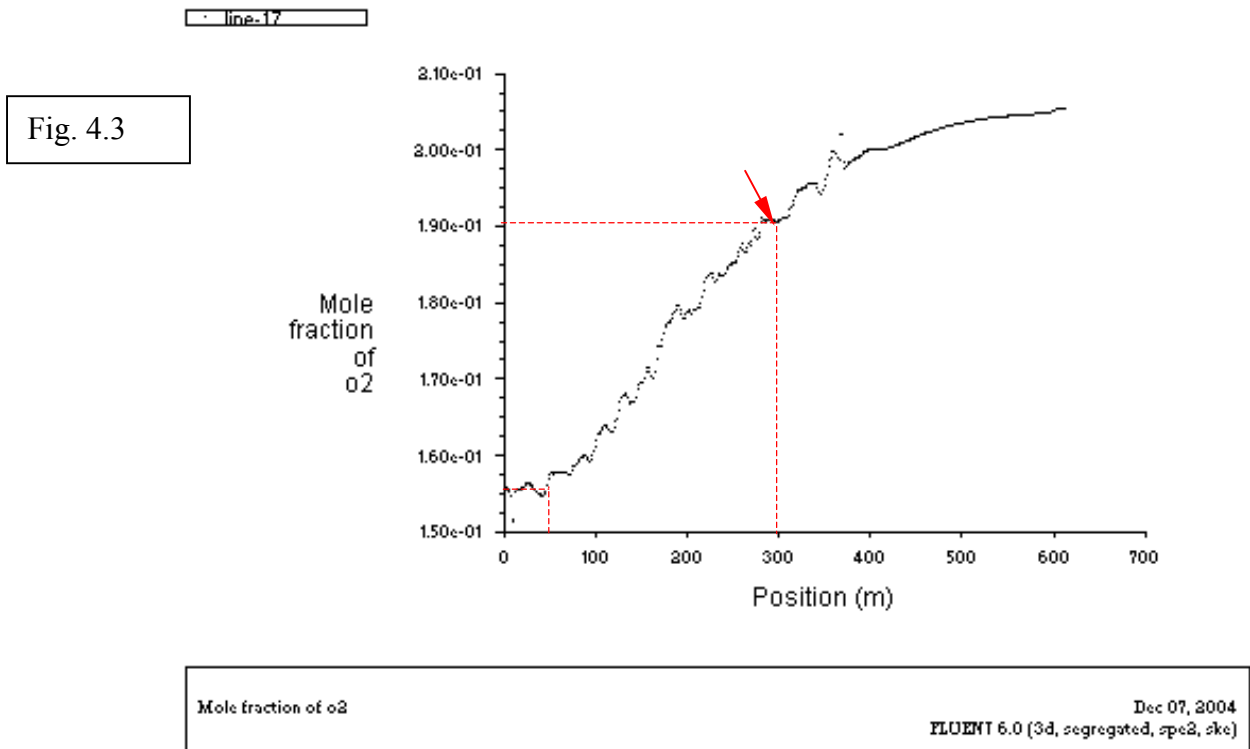

CASE V

Fig. 5.0

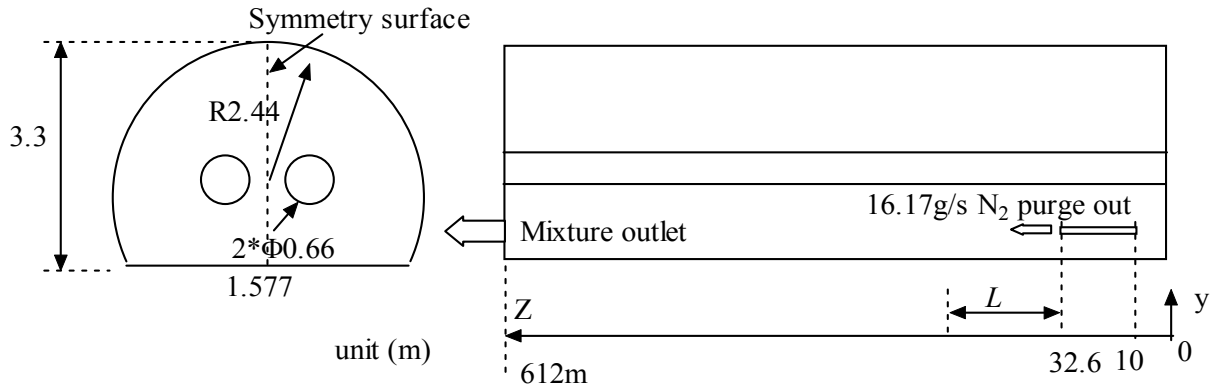

Fig.5.0 shows the cross section and straight length of one sextant. The room-temperature nitrogen from the magnets is purged into the tunnel by a “squirrel-cage” fan through an “elephant trunk” hose with inner diameter of 152.4 mm. The “elephant trunk” hose in 22.6m long runs from $z=10\text{m}$ to $z=32.6\text{m}$ in one side of the sextant.

The purging mass flow rate of GN_2 is 16.17g/s, while 83.54g/s air in tunnel is also sucked into the flow at $z=10\text{m}$, because of the high capacity of the fan. The mixture is then discharged into the same sextant at $z=32.6\text{m}$. At the other end of sextant, locally mixed gas is discharged out of this sextant.

For the short length of the hose comparing with the total length of tunnel, the locally circulating mixture around the hose is considered to have inappreciable effects on species distribution in tunnel, especially for most of the spaces away from the hose, so is neglected.

Two cases are modeled to investigate O_2 fraction variety at the ceiling just above the discharging point. One case is that the pure N_2 is discharged into the tunnel horizontally and another is that N_2 is discharged vertically.

5.1 N₂ discharging into the tunnel horizontally

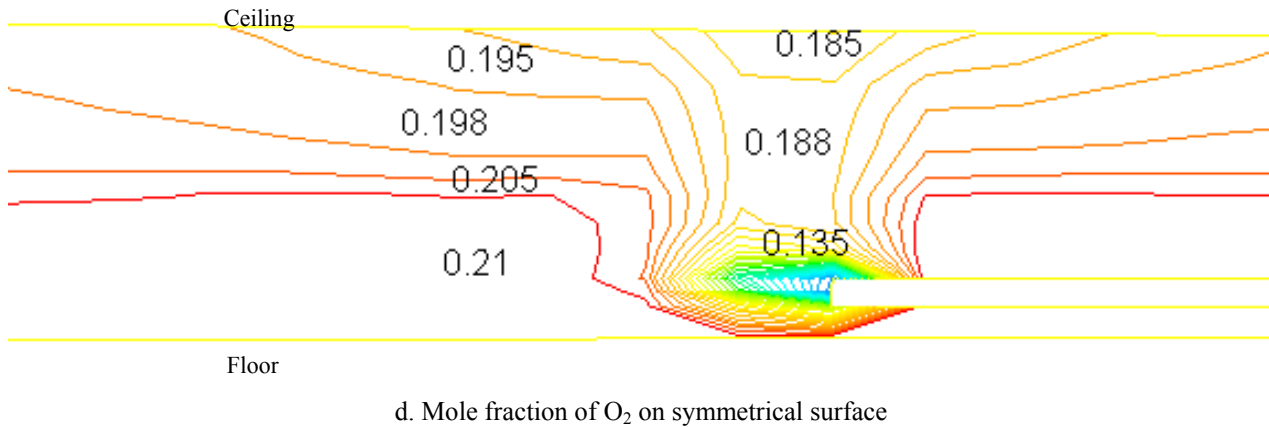
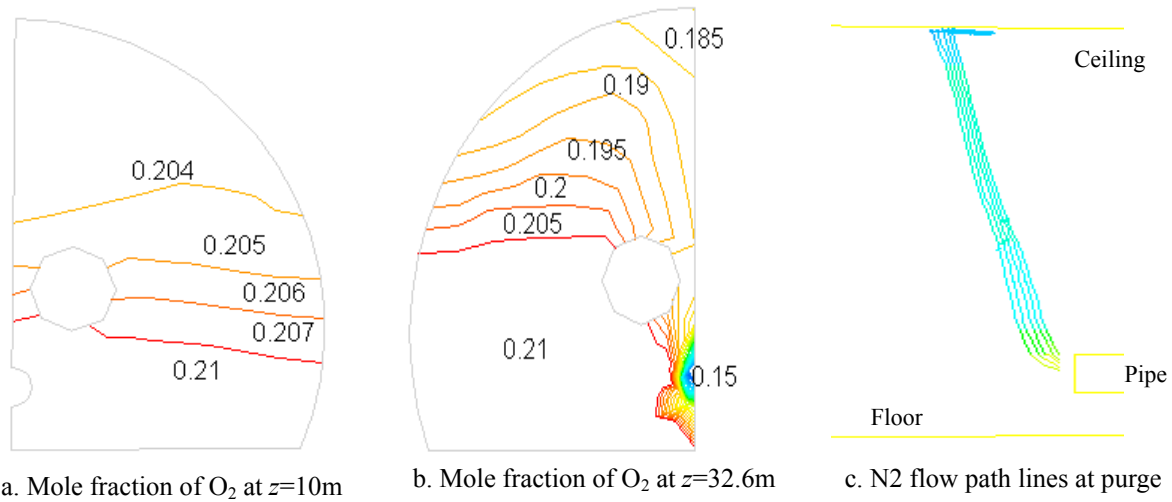

Fig. 5.1.1 Results of numerical simulation at $t=829s$

Fig. 5.1.1 shows the numerical simulation results of N₂ with mass flow rate of 16.17g/s discharging into the tunnel in $t=829s$. For the area at $z=32.6m$, the O₂ fraction at the ceiling above the discharging point quickly drops to 18.66% at 150s and to 18.5% at 829s from initial 21%, respectively.

For the area at $z=10m$, the O₂ fraction is only affected after about 5 minutes. It is 20.8% at $t=329s$ and 20.4% at $t=829s$. If the nearest oxygen sensor fitted in the ceiling at “working area,” $z=10m$ where is 22.6m away from the discharging point, it will alarm when the local O₂ mole fraction drops to 19% after about 2.5 hours, which is revealed by the simulation. However, the O₂ mole fraction near the discharging point, $z=32.6m$ has already dropped below 19% for over

2 hours. For the worst-case scenario, if any incidental breaks or failed bypass of the “squirrel-cage” or “elephant trunk”, close to where people happen to work, the ODH will take place.

It is also found from Fig. 5.1 b that the content of O_2 in center is lower than that at each side of the dome and it is always true for other cross sections along the tunnel, which revealed by the simulation.

The discharging velocity of GN_2 from the pipe is small and its disturbance to the fluid in tunnel is limited and localized. The molecules of N_2 go up right away from the hose in form of approximate bias, see Fig. 5.1 c, then they flow in adversely direction of air flow after get to the ceiling.

5.1.2

Fig. 5.1.2 shows the changes of mole fraction of O_2 with time at ceiling of the tunnel in different distances from the N_2 discharging point. The corresponding times that content of O_2 still keeps 21% at $L=50m$, $100m$, $150m$ are about 1250s, 4250s, 8050s, respectively. The contents of O_2 of these points drop linearly after a period of time, say, about 4 hours.

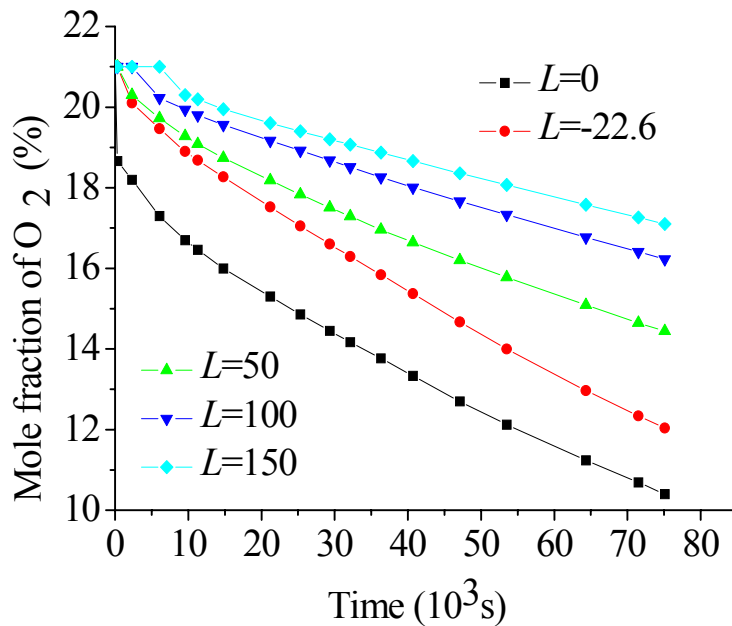

Fig. 5.1.2 Mole fraction of O_2 at points of ceiling of tunnel and at different distances L from discharging point changes with time.

5.1.3

Assuming the average height of the person working in tunnel is 1.8m, Fig. 5.1.3 gives the distribution of mole fraction of O₂ along the tunnel at height of 1.8m at different time. The propagation velocity of N₂ wave front (boundary of affected zone) decreases with time as expected because of the huge volume of tunnel. The velocity that N₂ wave front moves from z=150m to z=205m is 12.2mm/s, and it is 11.1mm/s from z=205m to z=255m. It takes about 75109s, 21 hours, to move to z=475m.

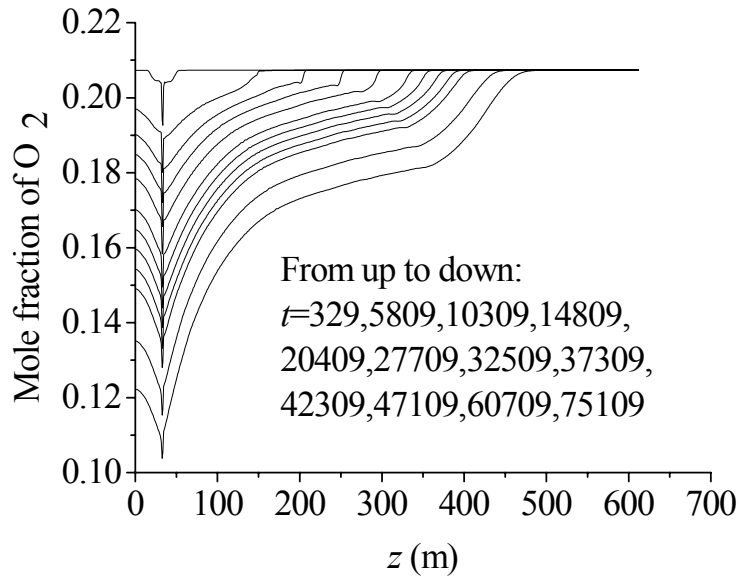
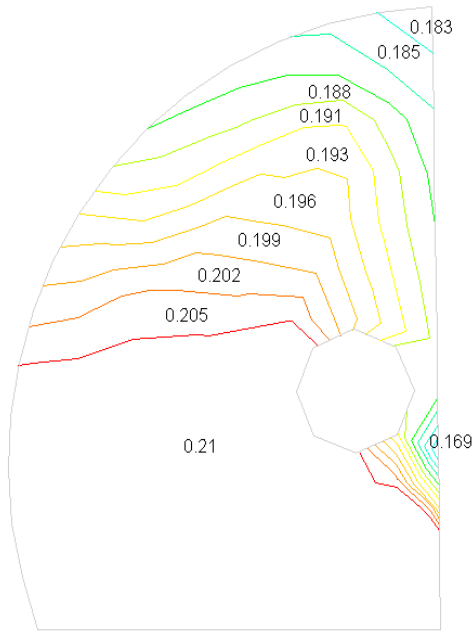

Fig. 5.1.3 Mole fraction of O₂ at height of 1.8m on symmetry surface at different times.

5.2 N₂ discharging into the tunnel vertically

For the case of N₂ discharging vertically into the tunnel and maintaining other boundary conditions unchanged from the horizontal case, the simulation results at $t=830s$ is given in Fig. 5.2. O₂ fraction at ceiling at $z=32.6m$ drops a little bit compared with the results in Fig. 5.1 at same time frame. No obvious discrepancies are found for those points beyond $z=82.6m$ for long enough time.



a. Mole fraction of O₂ at $z=32.6m$

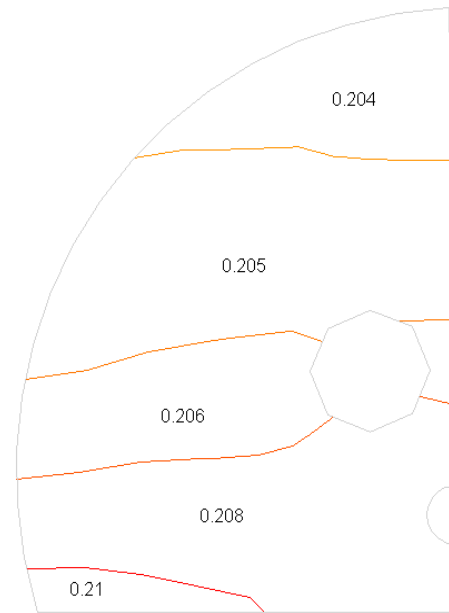

b. Mole fraction of O₂ at $z=10m$

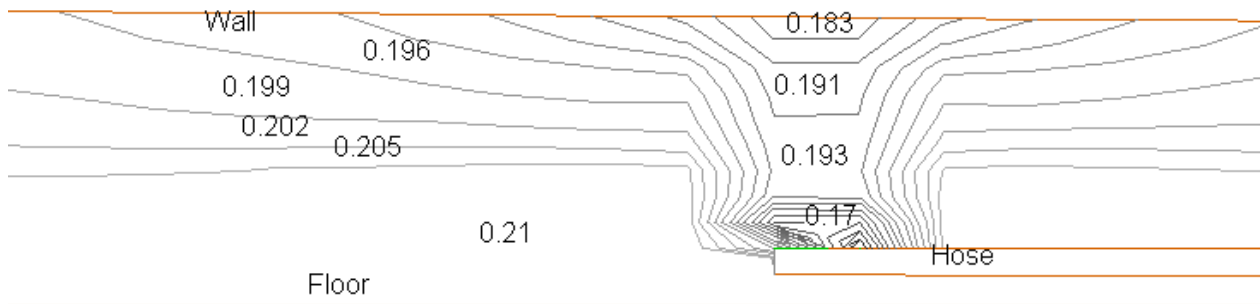

c. Mole fraction of O₂ on vertical symmetrical surface

Fig. 5.2 Results of numerical simulation at $t=830s$

5.3 Comparison of two cases

Fig. 5.3 shows mole fraction of O_2 at the point on the ceiling at $z=32.6m$ changes with time both for vertically and horizontally discharging with same mass flow rate. The O_2 fraction changes corresponding to the vertically case is somewhat faster than to the horizontally case assuming both discharging velocities are same and small.

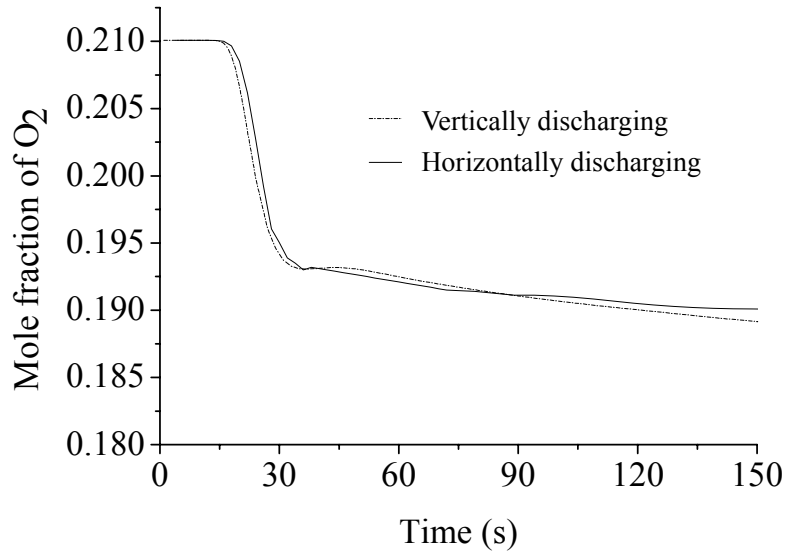

Fig. 5.3 Mole fraction of O_2 at points on ceiling at $z=32.6m$

End of report

Appendix 1

Memo

Accelerator Systems Safety Review Committee

date: October 11, 2004

to: J. W. Glenn

from: G.T. McIntyre

subject: Minutes from RHIC Tunnel Feedback Meeting held 09/14/04

Attendees: L. Jia, J. W. Glenn, G. McIntyre

The meeting was held to initiate an investigation into possible oxygen deficiency hazards caused by controlled and uncontrolled release of nitrogen purge gas into the RHIC tunnel. (See ASSRC minutes, "SubCommittee Meeting on ODH Controls at RHIC Related to Nitrogen Purge Gas Safety", dated 08/05/04)

W. Glenn tasked L. Jia with running calculations to determine the possible ODH due to the flow of 10 CFM of nitrogen gas into the tunnel. After further review this flow was increased to 30 CFM total.

Glenn ask McIntyre to provide Jia with the following information:

- 1. The velocity of the output air from the "squirrel-cage" fans used in the purge gas evacuation system.

Test performed by R. Anderson using a calibrated "hot-wire" anemometer revealed these results:

Unrestricted maximum performance of system

- Each of the four 1.5" ID inlet hoses to the fan had a maximum flow of 62 CFM with the inlets unrestricted.

- The maximum flow from the fan's 24 foot, 6"ID outlet hose was 230 CFM total.

Increasing the air pressure at the inlet did not increase the flow at the outlet.

Simulated In-tunnel maximum performance of system

- The four 1.5" ID inlet hoses to the fan were restricted to a 1/2 " inlet hole.

- The maximum flow from the fan's 24 foot, 6"ID outlet hose was reduced to 165 CFM total.

Increasing the air pressure at the inlet did not increase the flow at the outlet.

- 2. Volume of a tunnel sector, removing the volume of the superconducting magnets.

The volumes below are taken from the Sextant 1 Emergency Ventilation drawing SK-1.

sector 12- 16ft plate region -1	23800
sector 12- 16ft plate region -2	13500
sector 12- 16ft plate region -3	37100
sector 12- 16ft plate region -4	26180
sector 12- 16ft plate region -5	26180

sector 1- 16ft plate region -1	26180
sector 1- 16ft plate region -2	26180
sector 1- 16ft plate region -3	34150
sector 1- 16ft plate region -4	16030
sector 1- 16ft plate region -5	12880
sector 1- 20ft plate region -5	<u>341510</u>
	604945

Triplet volume	length	
D0 end can	33.5	140
D0	115.2	483
Q1D0 interconn	59.48	249
Q1	57.8	242
Q1Q2 interconn	37.75	158
Q2	163.8	686
Q2Q3 interconn	37.75	158
Q3	139.8	586
Q3 end can	37.63	158
Q3 end can interconn	41.28	<u>173</u>
		3033

Magnet volume		
(over 1440 feet long X 2)	1440	10619
	Magnet volume total	13651

Net Volume	
Tunnel volume - magnet volume	591294

3. Determine the approximate distance from the fan outlet to barricade.
 - Estimates put this distance at 15 feet.
4. Drawing showing tunnel geometry and a sketch of the purge gas evacuation system.
 - pdf of SK-1 and AutoCAD drawing, "Tunneldimensions.dwg", are attached showing tunnel geometry, as well as "Pgasevac1.dwg" showing a schematic of the purge gas evacuation system.

Appendix 2

SEXTANT 121 LAYOUT

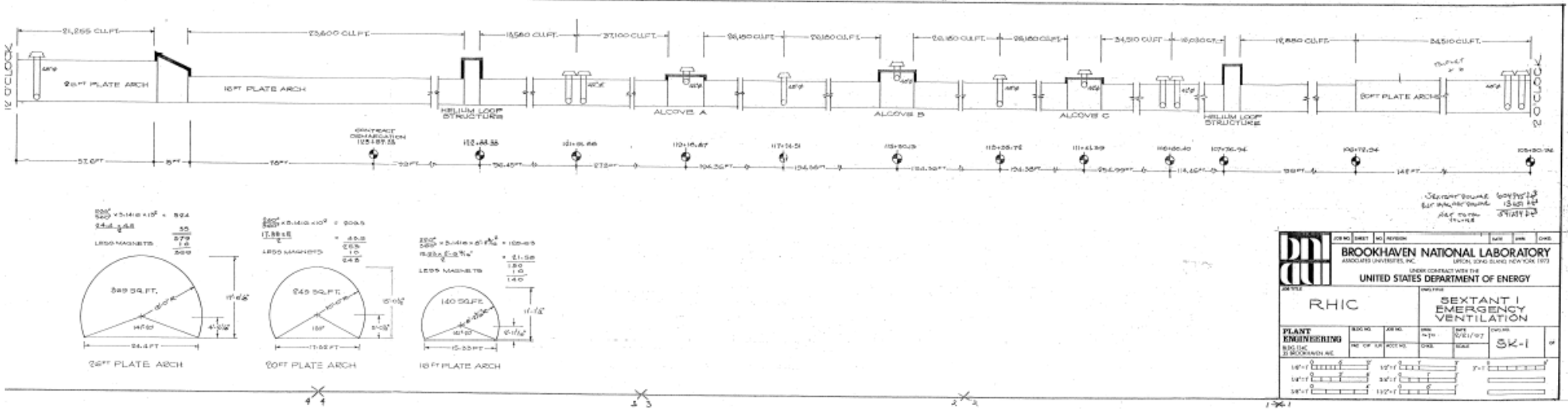

Appendix 3

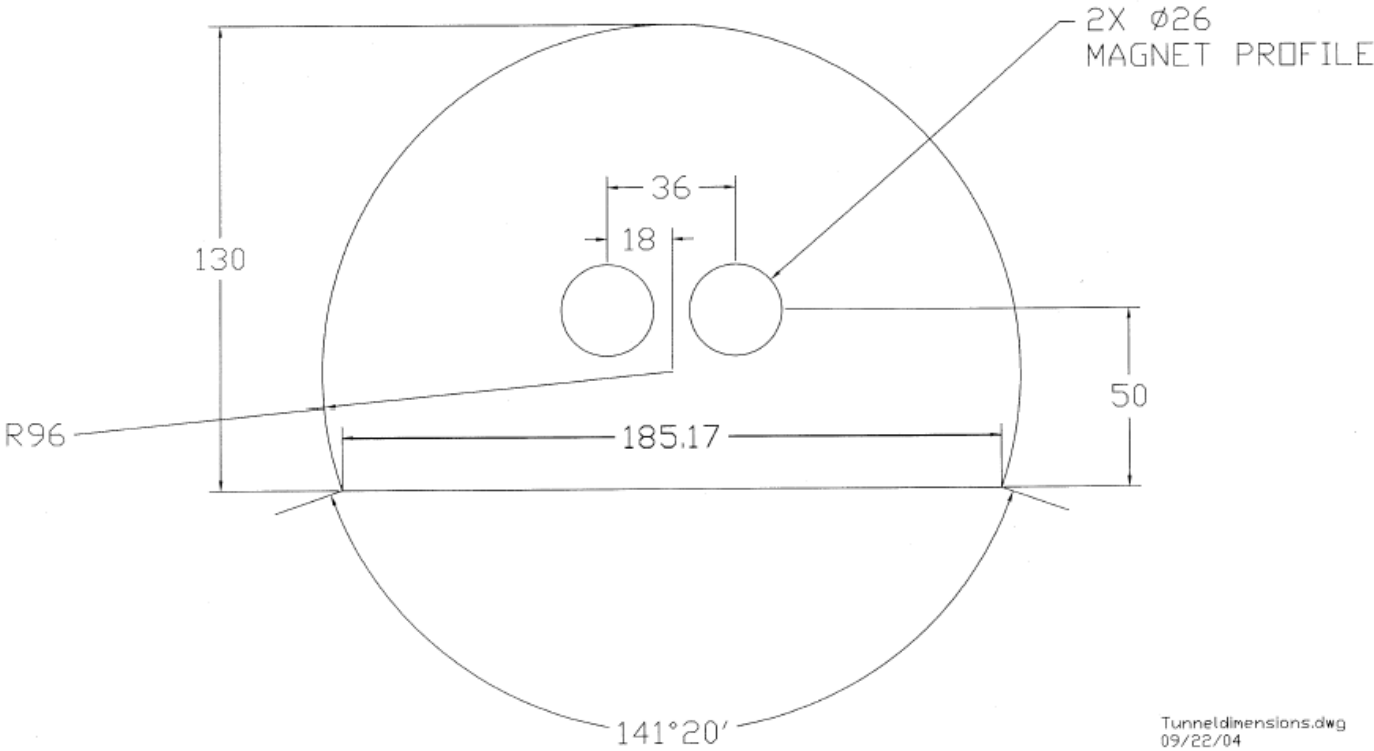

Ø 16 FT TUNNEL SECTION ALL DIMENSIONS IN INCHES

Tunneldimensions.dwg
09/22/04

Appendix 4

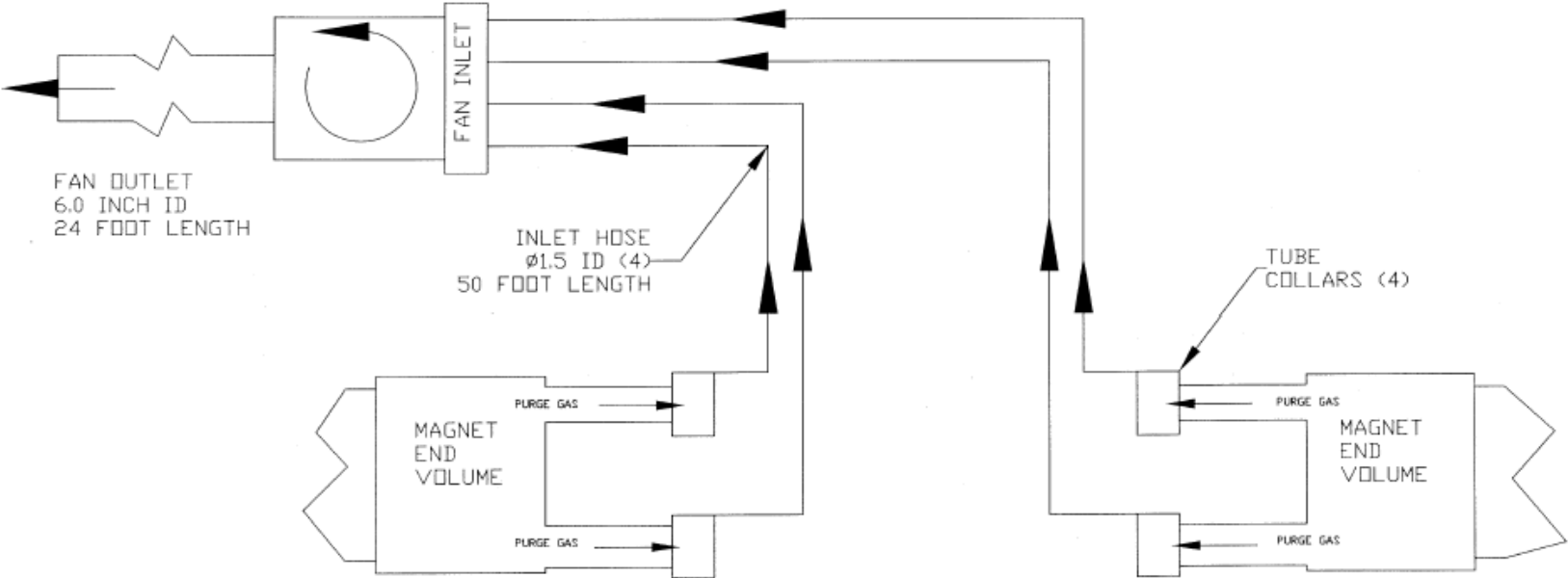

SCHEMATIC OF PURGE GAS EVACUATION SYSTEM

Pgssevac1.dwg
09/22/04

Flow out of evac system with 1/2" holes @ inlets (4)	165	CFM						
Flow from N2 purge gas (max.)	30	CFM						
Therefore, the purge gas is what % of total flow?	0.18							
Nitrogen is what % of ambient air?	0.78							
Air Nitrogen is what % of mixed air? ****	0.638181818							
Ambient + purge N2 is what percentage of outlet gas	0.82							
This leaves less than	0.18	O2						
% of O2 in ambient air is approximately	0.21							
		is needed to cause the POM to alarm at the inlet.						
	CFM N2	2	5	10	15	20	30	50
165-N2	CFM air	163	160	155	150	145	135	115
(CFM air * .785 + CFM N2)/ 165	N2 %	78.76%	79.15%	79.80%	80.45%	81.11%	82.41%	85.02%
1-%N2	O2 %	21.24%	20.85%	20.20%	19.55%	18.89%	17.59%	14.98%
	@hose end					****		