



BNL-105869-2014-TECH

EP&S No. 154;BNL-105869-2014-IR

Motor control system for the Expt. No. 821 Plan B compressor

V. Castillo

May 1998

Collider Accelerator Department
Brookhaven National Laboratory

U.S. Department of Energy

USDOE Office of Science (SC)

Notice: This technical note has been authored by employees of Brookhaven Science Associates, LLC under Contract No. DE-AC02-98CH10886 with the U.S. Department of Energy. The publisher by accepting the technical note for publication acknowledges that the United States Government retains a non-exclusive, paid-up, irrevocable, world-wide license to publish or reproduce the published form of this technical note, or allow others to do so, for United States Government purposes.

DISCLAIMER

This report was prepared as an account of work sponsored by an agency of the United States Government. Neither the United States Government nor any agency thereof, nor any of their employees, nor any of their contractors, subcontractors, or their employees, makes any warranty, express or implied, or assumes any legal liability or responsibility for the accuracy, completeness, or any third party's use or the results of such use of any information, apparatus, product, or process disclosed, or represents that its use would not infringe privately owned rights. Reference herein to any specific commercial product, process, or service by trade name, trademark, manufacturer, or otherwise, does not necessarily constitute or imply its endorsement, recommendation, or favoring by the United States Government or any agency thereof or its contractors or subcontractors. The views and opinions of authors expressed herein do not necessarily state or reflect those of the United States Government or any agency thereof.

or Internal Distribution Only

Alternating Gradient Synchrotron Department
Brookhaven National Laboratory
Brookhaven Science Associates
Upton, New York 11973-5000

EXPERIMENT PLANNING and SUPPORT DIVISION

AGS/EP&S Technical Note 154

MOTOR CONTROL SYSTEM
for the EXPT. NO. 821 'PLAN B' COMPRESSOR

V. Castillo, D. Derryberry, Z. P. Huang, T. Tallerico

May 1, 1998

**Alternating Gradient Synchrotron Department
Brookhaven National Laboratory
Brookhaven Science Associates
Upton NY 11973**

Experimental Planning and Support Division Technical Note

AGS / EP&S Technical Note No. 154

Motor Control System for the Expt No. 821 "Plan B" Compressor

V. Castillo, D. Derryberry, Z. P. Huang, T. Tallerico

The following description of the Motor Control System for the Experiment # 821 "Plan B" Compressor follows the Wiring Diagram: C Series Helium , SSC / CCI, Drawing No. 02250044-959, Rev 01 from Sullair Corporation, the Manufacturer of the compressor. This drawing also has the BNL Drawing No.: D19-E-116. For the purposes of this Tech note this drawing has been divided into 2 parts, each 8.5" x 11", and referenced as Fig 1, which contains the electrical information and Fig 2, which shows the mechanical layout of the various components in the control panel. This technical note deals almost exclusively with Fig 1.

Fig 1, the electrical diagram is divided into rungs: 1 thru 52, which are listed in the left margin of the diagram, and which run from left to right across the page. On the right side of the rung is, generally, a relay; some rungs just have indicator lights. In the right margin are listed numbers indicating the rungs where the contacts of the relay are located. Example on rung 6 is Relay 1CR with contacts on rungs 8 and 14.

This document examines the conditions that would make the various rungs conductive and the functions that will be performed when these rungs become conductive. **Information that is pertinent to SAFETY will be presented explicitly in the text.** The account has two parts, the first deals with starting the compressor in the Auto Mode and the second with loading and unloading the compressor in the Manual Mode.

Starting the compressor in the Manual mode and Loading and Unloading the compressor automatically will be described in Appendix-I because the compressor will not be operated in these modes at BNL. Appendix II has a summary of components in the control diagram and their functions.

PART - I: STARTING THE COMPRESSOR IN THE AUTO MODE

1. Power Panel Switch:

When the Power Panel Switch is closed 110VAC is fed to the rails of the control panel.

Conduction will take place across a rung if there is a conduction path.

SAFETY ITEM - 1:

When the power switch is closed there is 110 VAC in the wiring in the control panel. The exposed wiring is confined to the upper part of the panel. The Interlock Switches that need to be routinely accessed for resetting are in the lower part of the control panel.

2. Rung 1:

With relay 4CR contacts 9&3 normally closed, relay 1M contacts 9&3 normally closed and the Oil Heater Switch closed, the oil heater is powered and heats the oil. During a startup, when the start button is pressed, 1M gets powered opening contacts 9&3; relay 4CR on rung 14 gets powered, opening contacts 9&3, only if the SOP (Start Oil Pressure) switch also on rung 14 closes during startup.

3. Rungs 4 thru 8:

Rung 4 is the Interlock indicator rung. The interlocks are : HDT (High Discharge Temperature), HOT (High Oil Temperature), HD/LP (High Discharge / Low Pressure) and LOP (Low Oil Pressure). The RS (Remote Shutdown) is jumpered out for BNL application.

Rung 5 is the Startup, Emergency Stop and Protection Shutdown rung. The switches that control the interlocks mentioned above are located on this rung. All interlocks switches must be closed for startup, along with the Emergency Stop. The HDT, HOT, HD/LP switches have hardware resets at the switch locations in the lower compartment of the control panel. The LOP is reset by setting the AS/MR switch in the MR position and pressing the PB (Push Button). With all interlocks cleared and the AS / MR (Auto Start / Manual Reset) switch set to AS and the PB pressed, 1CR, the Protection Shutdown relay is powered. This closes 1CR 6&9, rung 8 and 1CR 8&5, rung 14.

Rung 8 sustains power on 1CR when contacts 6&9 are closed.

4. Rung 9 thru 12:

9CR is located on rung 9 and must be powered to satisfy the LOP interlock on rung 6. This is accomplished by setting the AS / MR switch to manual and pressing the PB.

On rung 12, 1TRA contacts 9&3 are normally closed for a preset period during startup and allows power to 9CR when the PB is pressed. When 9CR is powered contacts 6&9 close sustaining the power on 9CR and 5&8 close arming the LOP interlock on rung 6.

The LOP switch, on rung 9, which is open at startup closes when the oil pressure is > 25psi. When this happens it provides the current path to 9CR in place of 1TRA 9&3. If the LOP switch fails to close a LOP interlock is delivered to rung 6 (9CR 5&8 opens) and the system shutdowns.

5. Rung 11 thru 23:

For the compressor to start the Motor Start relay 4CR must be powered and the power on 4CR must be sustained.

But before this can take place the oil pressure levels must be satisfied. The next few steps accomplish this function.

Power gets to 1M, the oil pump contactor, during startup from rung 19 thru ART (Anti-Recycle Timer relay) contacts 1&4 which are normally closed, 11CRL contacts 6&9 which are latched closed at the end of a shutdown cycle, switch HSP (High Suction Pressure) which is closed if the suction pressure is above the cut in pressure (15 psia), 1CR 8&5 closed from paragraph 3, 1TRA normally closed contacts 2&8 and the oil pump timer 7TR contacts 8&5 which are normally closed and remain so for the setting (60 secs presently) of the timer, 7TR. See the Event-Time Sequence Diagram, Fig 3. Note that after the 60 secs timer setting, 7TR is powered and opens contacts 8&5, shutting down the Oil Pump.

If the oil pressure reaches the SOP (Start Oil Pressure) level within the 60 secs of the running of the oil pump the SOP switch will close supplying power to the Motor Start indicator on rung 11; 5CR, the Auxiliary Relay on rung 12; 4CR, the Motor Start Relay on rung 14 and the Hourmeter on rung 16.

When powered 4CR closes contacts 8&5 that will start the **MOTOR**; closes contacts 9&6 that sustains power to components fed by rung 14; closes contacts 4&7 putting power to 1TRA after a **10sec delay** set by 1TR.

When 1TRA is powered 1TRA contacts 9&3 opens cutting power from rung 12 to 9CR; 1TRA contacts 2&8 opens cutting power to 7TR and subsequently to 1M and to the oil pump; 1TRA contacts 1&7 open triggering the start of ART, the Anti-recycle Timer currently set for 26mins.

Before the end of that **10sec delay** the oil pressure must be > than 25psi for the LOP switch to close providing power to 9CR to prevent a LOP interlock and to allow a startup.

If the 25psi level is not attained before the 10 secs, the LOP switch does not close, 9CR loses power opening contacts 5&8 and setting up a LOP interlock.

When ART is triggered ART contacts 1&4 opens cutting power to components fed by rung 14 and ART contacts 1&3 closes powering the Anti-Recycle indicator. During the time, 26 mins that the ART is powered the compressor cannot be started. This is an equipment safety feature.

Summary of Startup in Auto Mode:

IN SUMMARY, FOR A STARTUP OF THE COMPRESSOR IN AUTO MODE ALL THE

INTERLOCKING FEATURES MUST BE CLEAR, THE AS/MR SWITCH MUST BE IN AUTO POSITION, THE PUSH BUTTON MUST BE PRESSED AND THE SOP PRESSURE MUST BE ATTAINED WITHIN 50 SECONDS AND THE LOP MUST BE ATTAINED WITHIN THE NEXT 10 SECS.

SAFETY ITEM - 2:

The function of the ART (Anti-Recycle Timer) is to prevent restart(s) of the compressor before the timer interval, set at 26 minutes by the Manufacturer. Restart(s) within the prescribed interval will DESTROY the MOTOR.

SAFETY ITEM - 3:

The function of 7TR (Oil Pump Timer) is to abort the startup by shutting down the Auxiliary Oil Pump if the oil pressure does not attain the SOP level within 60 secs. This time interval was set by the Manufacturer.

SAFETY ITEM - 4:

The function of 1TRA is to cut off the Auxiliary Oil Pump 10 secs after the SOP level is attained; transfer control of the LOP interlock to the LOP switch; and start the ART to prevent a restart before the prescribed time interval of 26 minutes.

SAFETY ITEM - 5:

The function of timer 1TR is to impose a fixed time period of 10 secs within which the SOP level must exceed the LOP level as a criterion for startup. If this criterion is not met 1TRA contacts 9&3 open taking power off 9CR and creating a LOP interlock.

PART - II: LOADING AND UNLOADING THE COMPRESSOR IN MANUAL MODE

SAFETY ITEM - 6:

The compressor load valve must be in the minimum position before shutting down the compressor. Alternately, at startup, the load valve must be in the minimum position. After a power failure the load valve will return to the minimum position when power is restored.

6. Rung 25:

The components on this rung control the motor-overload condition and will be handled in paragraph 12.

SAFETY ITEM - 7:

The Load/Auto/Unload switch must not be left in the Auto position for BNL application. It must be in either the Load or Unload position.

7. Rung 27 thru 39: (Loading the Compressor)

With the Load/Unload switch in the Load position and the PB pressed, on rung 27 current flows thru 1TRA 9&6, the Load switch contacts, rung 35, 4TR 1&4, rung 37, 12CRL normally closed contacts 1&7 to the Loading indicator and to 10CR normally closed 8&2. From 10CR 8&2 it powers the EVA (Electric Valve Actuator) to load the compressor and it unlatches 11CRL opening 11CRL contacts 6&9, rung 16 and closing 11CRL contacts 1&7, rung 29. Unlatching 11CRL prepares the Unloading circuit for the next unload cycle.

While the PB is pressed the compressor continues to load until the EVA reaches the maximum load position when EVA contacts 3&5 are closed and 12CRL is powered opening 12CRL contacts 1&7 taking power off the EVA. This terminates the loading process with the compressor in the maximum loaded position.

8. Rung 27 thru 39: (Unloading the Compressor)

With the Load/Unload switch in the Unload position and the PB pressed, on rung 27 current flows thru 1TRA 9&6, the Unload switch contacts, rung 33, 11CRL normally closed contacts 1&7 to the Loading indicator, rung 27, and to 10CR, the unload relay on rung 29. Power on 10CR opens 10CR normally closed contacts 8&2, closes 10CR 9&6 which allows power to the EVA to unload the compressor and unlatches 12CRL. Unlatching 12CRL prepares the Loading circuit for the next loading cycle.

While the PB is pressed the compressor continues to unload until the EVA reaches the minimum load position when EVA contacts 2&4, rung 31, are closed and 11CRL is powered opening 11CRL normally closed contacts 1&7, taking power off 10CR, thus opening 10CR 9&6 and taking power off the EVA. This terminates the unloading process with the compressor in the minimum load position.

Appendix -I

PART - I: STARTING THE COMPRESSOR IN THE MANUAL MODE

9. Startup in Manual Mode:

The compressor has to be started in manual mode if the suction pressure is below the cut-in pressure of the HSP switch, rung 16.

To start the compressor in manual mode all interlocks must be cleared as described in paragraph 3 and the AS/MR switch must be set to the AS position and the PB pressed. This powers 1CR, the Protection Shutdown relay but only prepares the compressor for startup because HSP is open. To effect the startup the AS/MR switch must now be set to the MR position. When this is done the startup sequence described in paragraph 5 commences, culminating with a startup.

PART - II: LOADING AND UNLOADING THE COMPRESSOR IN AUTO MODE

The compressor loads and unloads automatically when the Load/Unload switch is set in the Auto position, closing the switch contacts on rung 45.

Automatic Loading and Unloading is controlled from the suction pressure by a dual set-point pressure switch P1-LO, rung 29, and P2-HI, rung 37. Above the high suction pressure P2 the compressor loads and below the low suction pressure P1 the compressor unloads. Between P1 and P2 the compressor maintains a constant capacity, neither loading or unloading.

The compressor also unloads automatically for a motor-overload condition, i.e. the motor draws more than the full-load current of 60 amps. **This will be described separately under unloading for motor overload.**

10. Rung 25 thru 48: (Loading the Compressor in Auto mode)

With the Load/Unload switch in the Auto position and the suction pressure above the high suction pressure, P1-LO contacts com & no close along with P2-HI contacts c & no.

Current gets to the EVA from rung 27 thru 1TRA contacts 9&6, closed because 1TRA is powered, thru P1-LO contacts com & no, thru P2-HI, contacts com & no, thru 3TR contacts 1&3 which are closed momentarily, see Fig 4, each timer period, set for 50 secs by Manufacturer, thru 4TR 1&4. Power thru P1-LO also gets to Capacity Control Timer, 3TR, rung 45 thru the closed contacts of the Load/Unload switch.

With power to 4TR 1&4 the loading process follows the account described in paragraph 7. The EVA is pulsed in the loading direction by the momentary closing of 3TR 1&3 until the compressor is fully loaded.

11. Rung 25 thru 45: (Unloading the Compressor in Auto mode)

When the suction pressure falls below the P1 set-point P1-LO contacts com & nc close along with P2-HI contacts com & nc. On rung 27 current flows thru 1TRA contacts 9&6, closed from startup, thru P2-HI com & nc to both Timer 3TR, rung 45 and thru P1-LO com & nc to 3TR 8&6 which are momentarily closed, see Fig 4, each timer period and which thru 11CRL normally closed contacts 1&7 power 10CR. With 10CR powered the unloading process follows the description given in paragraph 8.

12. Rung 25 thru 48: (Unloading the Compressor for motor-overload condition)

The Amp relay, with contacts on rung 25, is located in the main power panel external compartment and is powered by a current sensing transformer inductively coupled to one of the incoming power lines. When the current to the motor crosses a set point the Amp Relay is powered and closes its contacts allowing power to 13CR. When powered 13CR closes contacts 5&8, rung 46. This causes 4TR (Load Limit Timer) to open 4TR contacts 1&4 and close 4TR contacts 1&3 which prevents loading and powers the Load Limiting indicator on rung 41. 13CR also closes 13CR contacts 9&6 on rung 32 sending power to 11CRL 1&7, and relay 10CR both on rung 29. Power on 10CR closes 10CR 9&6 and puts power to the EVA to unload, as described in paragraph 8.

When the power in the Amp Relay drops below the pull-in level 13CR loses power and opens contacts 13CR 5&8 which starts 4TR timing for the set time which is 60 secs. After this time 4TR contacts 1&3 open extinguishing the Load Limiting indicator and contacts 1&4 close, providing a current path to the EVA and thus permitting the loading process.

Appendix -II
Summary of Active Components and their Function(s)

Item	Component	Sub-Assby	Rung No.	Description, Function(s) and Other Details
1	1CR	Relay Coil	6	Protect shutdown relay.
	"	NO: 6&9	8	Sustains power on 1CR after 1CR is powered.
	"	" 8&5	14	Takes power off Motor Start Relay when there is an Interlock.
2	1TR	Timer	18	Provides 10 sec delay for relay 1TRA to allow oil pressure to go from SOP to LOP (>25PSI), a startup criterion.
3	1TRA	Relay Coil	18	Controls Auxiliary Oil Pump, Anti-Recycle timer and Loading/Unloading processes.
	"	NC: 9&3	12	Provides current path for 10 secs to 9CR until LOP switch closes.
	"	" 2&8	20	Provides current path for 10 secs to 7TR, Oil Pump Timer and 1M, Oil Pump Contactor.
	"	NO: 9&6	27	Controls Loading, Unloading and Motor-overload Protection processes.
	"	NC: 1&7	42	Starts the Anti-Recycle timer 10 secs after SOP switch closes.
4	1M	Relay Coil	20	Controls the Auxiliary Oil Pump.
	"	NC: 3&9	1	Provides current path for Oil Heater.
	"	NO: 4&7	50	Provides current path for Auxiliary Oil Pump motor.
5	3TR	Timer	39	Controls Loading/Unloading in Auto mode providing pulsed power according to setting.
	"	NO: 8&6	29	Provides pulsed power thru 10CR for Unloading process.
	"	NO: 1&3	37	Provides pulsed power thru 12CRL 1&7 for the Loading process.
6	4CR	Relay Coil	14	Controls Compressor Motor Startup.
	"	NC: 9&3	1	Provides current path for Oil Heater.

Appendix -II (Cont'd)
Summary of Active Components and their Function(s)

Item	Component	Sub-Assby	Rung No.	Description, Function(s) and Other Details
	4CR	NO: 9&6	14	Provides current path for rung 14 after startup.
	"	" 4&7	18	Provides current path for 1TRA after startup.
	"	NC: 8&2	31	Provides current path for Unloading process after recovery from power shutdown.
	"	NO: 8&5	50	Controls power to the Compressor Motor Contactor.
7	4TR	Timer	48	Defeats the Loading process during a Motor-overload condition. Controlled by 13CR, rung 25.
	"	NC: 1&4	37	Must be closed for the Loading process.
	"	NO: 1&3	37	Close to defeat Loading process during Motor-overload condition and powers Load Limiting indicator.
8	5CR	Relay coil	12	Controls the ART. Controls solenoid to EV69 which is not used for BNL application.
	"	NO: 9&6	42	Controls the ART.
	"	NO: 8&5	52	Controls solenoid to EV69 which is not used for BNL application.
9	9CR	Relay coil	9	Controls the LOP interlock and sustains power on itself.
	"	NO: 5&8	6	Controls the LOP interlock.
	"	NO: 6&9	12	Sustains power on 9CR.
10	11CRL	Relay coil	31	A Latching relay: provides current path to 4CR for startup; controls the Unloading process.
	"	NO: 6&9	16	Provides current path to 4CR for startup, by being latched closed at shutdown.
	"	NC: 1&7	31	Provides current path to EVA during the Unloading process.
11	12CRL	Relay coil	35	A Latching relay which controls the current path to the EVA during the Loading process.

Appendix -II (Cont'd)
Summary of Active Components and their Function(s)

Item	Component	Sub-Assby	Rung No.	Description, Function(s) and Other Details
	12CRL	NC: 1&7	37	Controls power to the EVA the Loading process.
12	13CR	Relay Coil	25	Controls the Unloading process for the Motor-overload condition.
	"	NO: 9&6	32	Provides current path to EVA for Unloading process during Motor-overload condition.
	"	NO: 5&8	46	Triggers 4TR to terminate Loading when a Motor-overload condition arises.
13	7TR	Timer	21	Cuts power to the Auxiliary Oil Pump if the startup is aborted.
	"	NC: 8&5	20	Controls current path to Oil Pump Contactor.
14	ART	Timer	44	Anti-Recycle Timer which prevents restart(s) after an aborted startup. It is set at 26 mins presently. This is a Safety feature to prevent destruction of the Compressor motor.
	"	NC: 1&4	19	Provides a current path to 4CR during startup.
	"	NO: 1&3	19	Closes for the setting of the timer, preventing restart and powering the Anti-Recycle indicator.
15	Amp Relay	Relay	Pwr. Pnl.	This is powered by a Current Transformer coupled to an Input power line for sensing Motor-overload.
	"	NO: A-R	25	Close during Motor-overload and along with 13CR initiate the Unloading process.
16	EVA	Motor	33	Electric Valve Actuator (motor) that moves the Slide Valve to set the Load/Unload level.
	"	2&4	31	Contacts close at the minimum Load position.
	"	3&5	35	Contacts close at the maximum Load position.
17	Aux Oil Pump	Oil Pump	50	Oil pump that provides lubrication during startup.
18	HM	Hour Meter	16	Records the cumulative runtime of the compressor.

Appendix -II (Cont'd)
Summary of Active Components and their Function(s)

Item No.	Component	Sub-Assby	Rung No.	Description. Function(s) and Other Details
19	OHU	Oil Heater Unit	1	Located at the base of the Oil Separator. It is powered with the main switch and loses power when there is power on 4CR and or 1M.
20	HDT	Interlock switch	6	Opens normally closed contacts to shutdown compressor for High Discharge Tempt.
21	HOT	Interlock switch	6	Opens normally closed contacts to shutdown compressor for High Oil Tempt.
22	HD/LP	Interlock switch	6	Opens normally closed contacts to shutdown compressor for High Discharge or Low suction pressure.
23	LOP	Interlock contacts	6	Contacts open when Low Oil Pressure criterion is not met during startup. Controlling relay 9CR loses power.
24	RS	Interlock contacts	6	This interlock is jumered out for BNL application.
25	LOP	Sensor switch	9	This normally open switch closes when the LOP criterion is satisfied during startup and while the compressor is operating.
26	SOP	Sensor switch	14	This normally open switch closes when the SOP criterion is satisfied during startup and remains closed while the compressor is operating.
27	HSP	Sensor switch	16	Senses suction pressure and starts/stops compressor operating in Auto mode.
28	P1-LO	Sensor switch	29	Monitors the Suction pressure and along with P2-HI controls the Loading/Unloading process of the compressor.
	"	NO: com & no	29	When the suction pressure is above the suction pressure limit these contacts are closed to allow the Loading process.
	"	NC: com & nc	29	When the suction pressure is below the suction pressure limit these contacts are closed to allow the Unloading process.

Appendix -II (Cont'd)
Summary of Active Components and their Function(s)

Item No.	Component	Sub-Assby	Rung No.	Description, Function(s) and Other Details
29	P2-HI	Sensor switch	37	Monitors suction pressure and along with P1-LO controls the Loading/Unloading process.
	"	NO: com & no	37	When the suction pressure is above the suction pressure limit these contacts are closed to allow the Loading process.
	"	NC: com & nc	37	When the suction pressure is below the suction pressure limit these contacts are closed to allow the Unloading process.
30	AS/MR	Switch	6	Dual position switch with PB option.
	"	AS posn.	6	With interlocks cleared and PB pressed the compressor will attempt to start. Startup will be completed only if oil pressure criteria are satisfied.
	"	MR posn.	6	Pressing the PB will clear the LOP interlock. This position is used to start the compressor if the suction pressure is below the HSP setpoint.
31	Load/ Auto/ Unload	Switch	33	Used for Manual or Automatic control of the Loading and Unloading processes.
	"	Load posn.	35	This is the position for manual Loading of the compressor; the compressor loads each time the PB is pressed.
	"	Auto posn.	39	This is the position for the compressor to automatically Load and Unload.
	"	Unload posn.	33	This is the position for manual Unloading of the compressor. The compressor unloads each time the PB is pressed.
32	Stop	Switch	6	This switch shuts the compressor down when it is pressed because it takes power off 1CR, the protect shutdown relay.
33	EV69	Valve	52	Not used in BNL application.

Reference(s):

1. Operator's Manual, Sulair Refrigeration C Series Compressor Package, Part No. 252666, Sulair Corporation, effective 10/82.

REFERENCE LINE (RUNG)

120VAC 2.5 KVA
FROM MOTOR STARTER

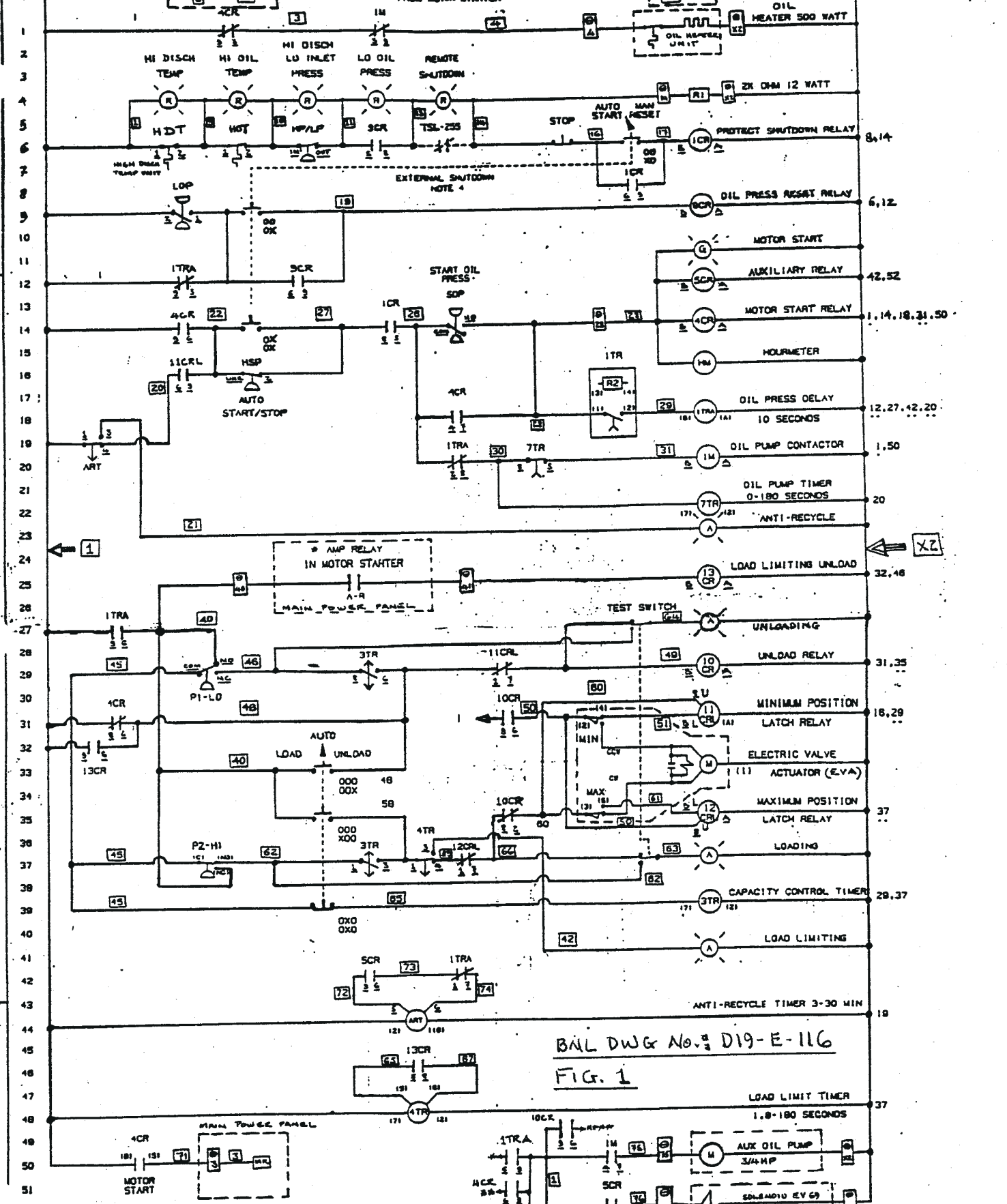

BAL DWG No. 1/2 D19-E-116
FIG. 1

NOTES:

1. THIS SCHEMATIC WAS THE PRODUCT OF A POINT TO POINT CHECK OF THE CONTROL PANEL BEING CONDUCTED BY E.P. HUANG AND V. CASTILLO.
2. NOMENCLATURE: READABLE NO. CONNECTOR NO. TERMINAL NO. ON STRIP
 EXTERNAL TO CONTROL PANEL
3. THIS PRELIMINARY SCHEMATIC IS VALID AS OF 10/16/97

- SEE REFERENCE LINE # 27
28 " " " " # 29
30 " " " " # 31
32 " " " " # 31

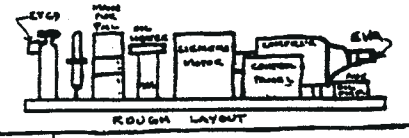

THIS DOCUMENT AND THE INFORMATION DISCLOSED HEREIN ARE PROPRIETARY TO SULLAIR CORPORATION AND MUST BE RETURNED UPON DEMAND. REPRODUCTION OR USE OF ANY INFORMATION DISCLOSED HEREIN, OR THE MANUFACTURE OF ANY ASSEMBLY OR PART DEPICED HEREIN, IS PERMITTED ONLY TO THE EXTENT EXPRESSLY AUTHORIZED IN WRITING BY SULLAIR CORPORATION AND ONLY FOR THE PURPOSE FOR WHICH THIS DOCUMENT IS PROVIDED.

REVISIONS				
REV	CH NO.	DESCRIPTION	DATE	APPROVED
00	39350	RELEASED	12/16/91	GK/KNP
01	39865	ADDED STARTER TIE IN TB'S	01/16/92	GK/KNP

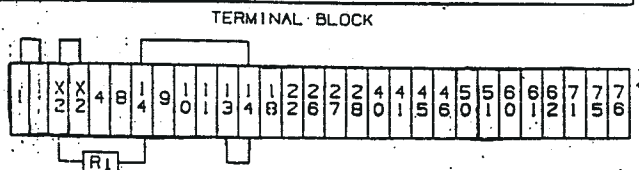
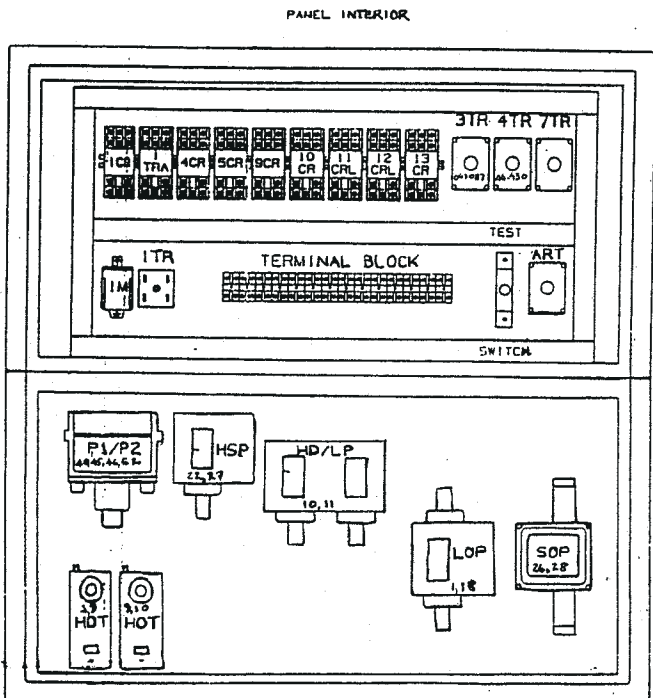
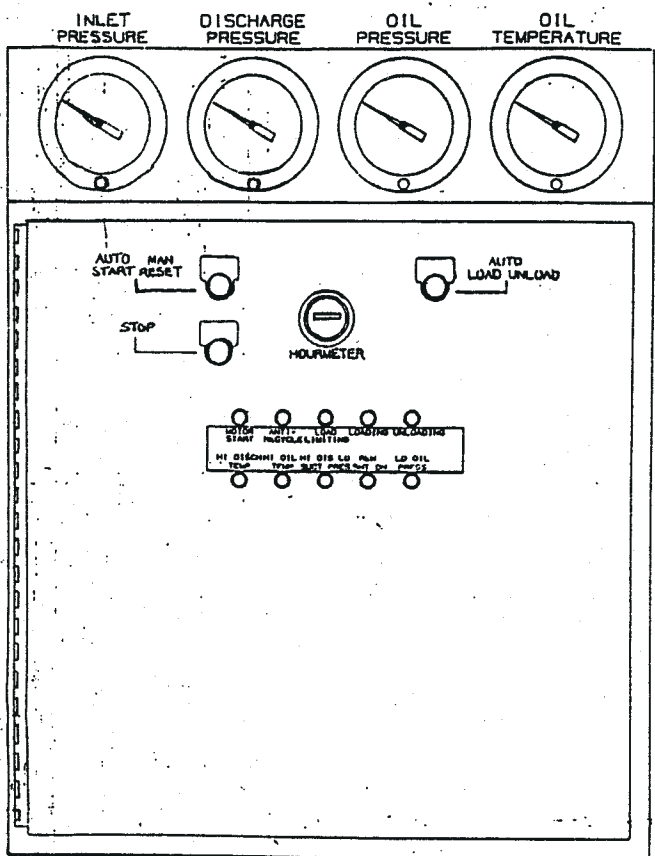

NOTES

- 1- WIRING DIAGRAM SHOWN WITH NO POWER APPLIED. EQUAL PRESSURES, NORMAL TEMPERATURES, VALVE ACTUATOR AT MINIMUM CAPACITY POSITION.
- 2- FIELD WIRING SHOWN BETWEEN DASHED LINES.
- 3- () DENOTES TERMINAL CONNECTIONS AT SPECIFIC DEVICE, (XX) STARTER TERMINALS.
- 4- TERMINALS 13, 14 FOR EXTERNAL PROTECT SHUTDOWN REMOVE JUMPER WHEN USED.

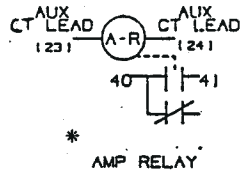
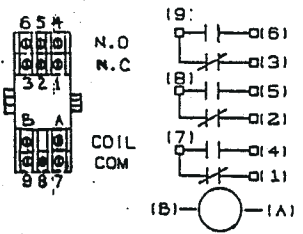
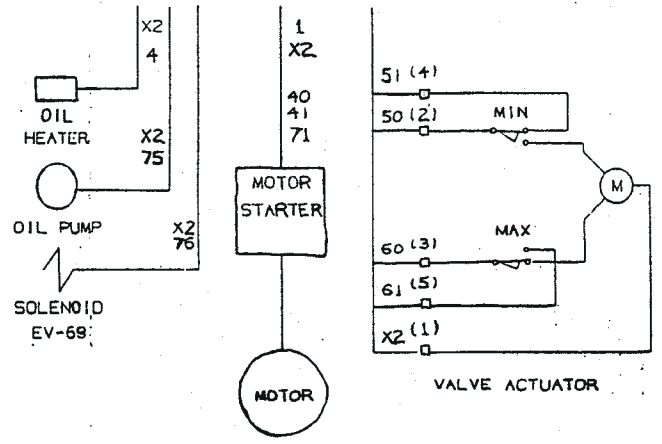

BNL DWG No.: D19-E-110.
FIG. 2

QTY	ITEM NO.	PART NO.	DESCRIPTION	REV	QTY
PARTS LIST (BILL OF MATERIAL)					
MATERIAL SPEC & WEIGHT					
FINISH: 01 - 17 UNLESS NOTED, 02 - AS CAST UNLESS NOTED					
HEAT TREAT, HARDNESS, PAINT PER SULLAIR SPEC. NO., OTHER (SPEC.)					
THIS PRINT IS THE PROPERTY OF SULLAIR CORPORATION AND MAY NOT BE COPIED OR GIVEN TO ANY OTHER CONCERN WITHOUT THE CONSENT OF SULLAIR CORPORATION.					
SULLAIR CORPORATION SUBSIDIARY OF BLACKBURN CORPORATION MICHIGAN CITY, INDIANA					
WIRING DIAGRAM C SERIES HELIUM SSC/CCI					
APPRV	KP	DATE	12/16/91		
CHECKED	KP	DATE	12/16/91		
DRAWN	GK	DATE	12/16/91		
DWG NO	31654	DWG NO	02250044-959	REV	01

SULLAIR

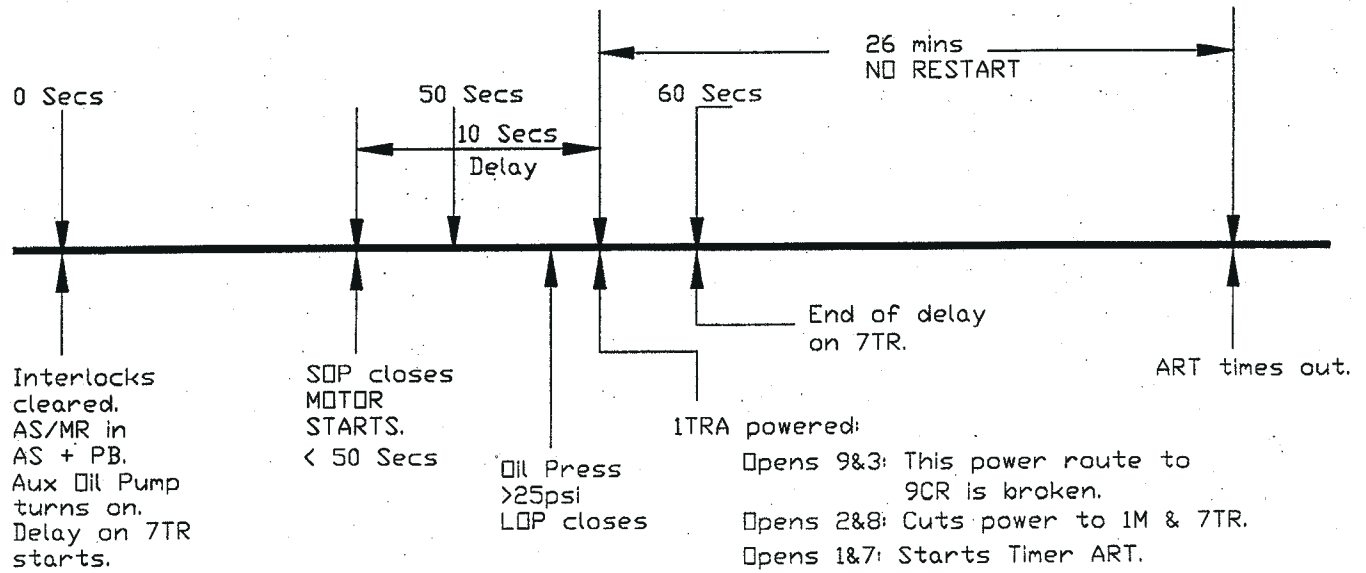

FIG. 3: Event-Time Sequence Diagram.

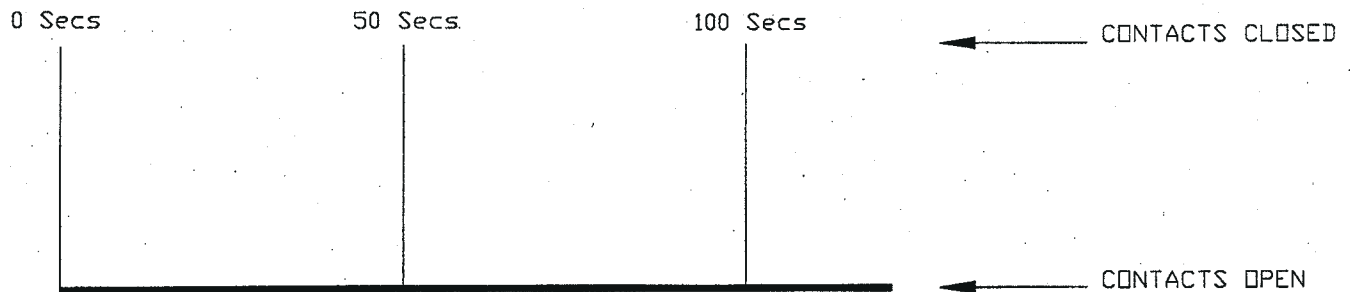

FIG. 4: Pulsed power thru 3TR contacts 1&3; 8&6 for Automatic LOADING/UNLOADING. Contacts are closed momentarily (settable time) each period, 50 secs, which is also settable.