



Brookhaven
National Laboratory

BNL-99515-2013-TECH

C-A/AP/368;BNL-99515-2013-IR

Energy Recovery Linac: Vacuum

M. Mapes

January 2010

Collider Accelerator Department
Brookhaven National Laboratory

U.S. Department of Energy

USDOE Office of Science (SC)

Notice: This technical note has been authored by employees of Brookhaven Science Associates, LLC under Contract No. DE-AC02-98CH10886 with the U.S. Department of Energy. The publisher by accepting the technical note for publication acknowledges that the United States Government retains a non-exclusive, paid-up, irrevocable, world-wide license to publish or reproduce the published form of this technical note, or allow others to do so, for United States Government purposes.

DISCLAIMER

This report was prepared as an account of work sponsored by an agency of the United States Government. Neither the United States Government nor any agency thereof, nor any of their employees, nor any of their contractors, subcontractors, or their employees, makes any warranty, express or implied, or assumes any legal liability or responsibility for the accuracy, completeness, or any third party's use or the results of such use of any information, apparatus, product, or process disclosed, or represents that its use would not infringe privately owned rights. Reference herein to any specific commercial product, process, or service by trade name, trademark, manufacturer, or otherwise, does not necessarily constitute or imply its endorsement, recommendation, or favoring by the United States Government or any agency thereof or its contractors or subcontractors. The views and opinions of authors expressed herein do not necessarily state or reflect those of the United States Government or any agency thereof.

C-A/AP/#368
January 2010

R&D ERL: Vacuum

M. Mapes, L. Smart, D. Weiss, A. Steszyn, R. Todd



**Collider-Accelerator Department
Brookhaven National Laboratory
Upton, NY 11973**

Notice: This document has been authorized by employees of Brookhaven Science Associates, LLC under Contract No. DE-AC02-98CH10886 with the U.S. Department of Energy. The United States Government retains a non-exclusive, paid-up, irrevocable, world-wide license to publish or reproduce the published form of this document, or allow others to do so, for United States Government purposes.

R&D ERL – VACUUM

Contributors: L Smart, D. Weiss, A. Steszyn, R. Todd, M. Mapes

Contents

1. Vacuum Systems Description, General Overview & Introduction
2. Vacuum Systems Details
 - 2.1 Superconducting RF Cavities (Beamline and Cryostat Vacuum): 5-cell, e-gun
 - 2.2 Loop Beamline
 - 2.3 Injection Beamline: G5, Zig-Zag
 - 2.4 Laser Transport
3. Instrumentation & Control
4. Installation and Assembly
5. Research & Development Efforts
 - 5.1 Particulate Free Processing
 - 5.2 SRF Bakeout
 - 5.3 CETs
 - 5.4 Helium Processing
 - 5.5 Diamond Amplified Photocathode Development

Supporting material appendices are NOT included in this document.

1. ERL Vacuum Systems Description: General Overview & Introduction

The ERL Vacuum systems are depicted in Figure 1. ERL has eight vacuum volumes with various sets of requirements. A summary of vacuum related requirements is provided in Table 1.

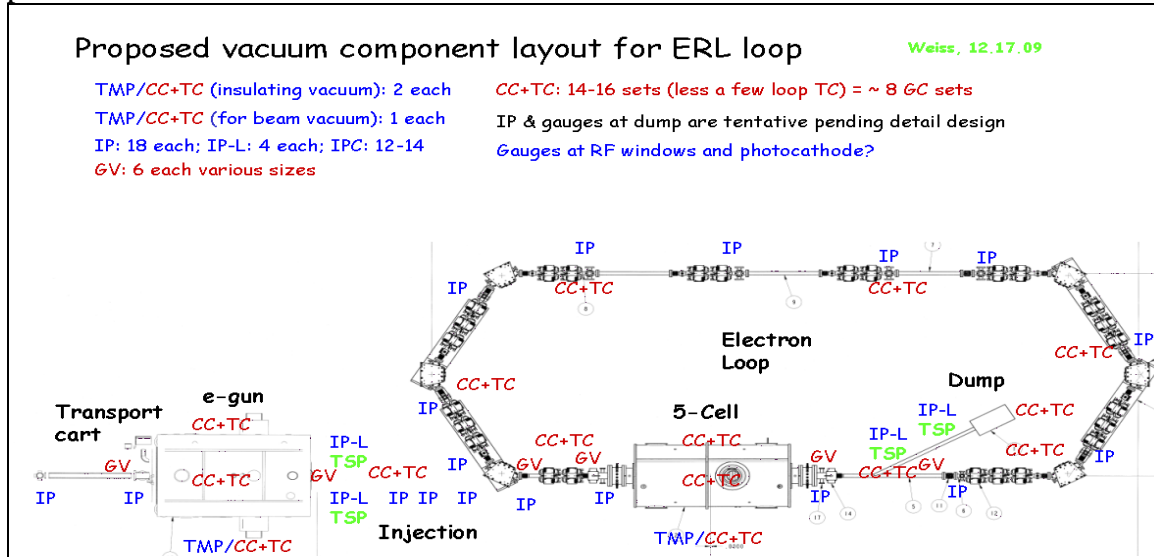

Figure 1. ERL Vacuum Systems

Five of the eight volumes comprise the electron beamline. They are the 5-cell Superconducting RF Cavity, Superconducting e-gun, injection, loop and beam dump. Two vacuum regions are the individual cryostats insulating the 5-cell Superconducting RF Cavity and the Superconducting e-gun structures. The last ERL vacuum volume not shown in the schematic is the laser transport line.

Vacuum Region	Target Vacuum torr	Length meters	Temperature °K	Bakeout	Pumps	Gauges	Materials	Seal Technology
e-gun Beam line	10 ⁻¹¹	1.7	2-293 ¹	120°C Prebake ³	1(60 IP)	1 CC, 1 TC	Nb - SST	Al Hex - Conflat
e-gun Cryostat	10 ⁻⁷	1.5	2-293 ²	No	1(300 TMP)	2 CC, 2 TC	steel	Conflat - ISO
Injection	10 ⁻¹¹ at e-gun exit	6.0	293	150°C in-situ	2(200 IP) 3(25 IP)	1 CC, 1 TC	SST	Conflat - Helicoflex
5-cell Beamline	10 ⁻¹¹	3.2	2-293 ¹	120°C Prebake ³	2(25 IP)	3 CC, 1 TC	Nb - SST	Al Hex - Conflat
5-cell Cryostat	10 ⁻⁷	2.0	2-293 ²	No	1(300 TMP)	2 CC, 2 TC	steel	Conflat - ISO
Electron Loop	10 ⁻⁹	23.0	293	No	11(25 IP)	7 CC, 7 TC	Inconel, Al, SST	Conflat - Helicoflex
Beam Dump	10 ⁻⁹	3.2	293	No	2(200 IP)	1 CC, 1 TC	SST	Conflat - Helicoflex ⁴
Laser Transport	10 ⁻³	5.5	293	No	1(25 IP)	1 CM	SST	Conflat

1. Portions of beamline operate at 2K while ends beyond thermal transitions operate at room temperature
 2. Portions of cryostat surrounding He vessel operate at 2K while outer vacuum vessel operates at room temperature
 3. String Assembly within helium vessel heated to 120C prior to installation by passing heated N2 through the He vessel.
 4. Design incomplete. May incorporate EVAC Chain clamp technology in certain connections for ALARA exposure.

Table 1. Vacuum Systems Requirements and Parameter Summary

The beamline vacuum regions are separated by electropneumatic gate valves. The beam dump is common with loop beamline but is considered a separate volume due to geometry and requirements. Vacuum in the 5-cell SRF cavity is maintained in the ~10⁻⁹ torr range at room temperature by two 20 l/s ion pumps and in the e-gun SRF cavity by one 60 l/s ion pump. Vacuum in the SRF cavities operated at 2°K is reduced to low 10⁻¹¹ torr via cryopumping of the cavity walls. The cathode of the e-gun must be protected from poisoning, which can occur if vacuum adjacent to the e-gun in the injection line exceeds 10⁻¹¹ torr range in the injection warm beamline near the e-gun exit. The vacuum requirements for beam operation in the loop and beam dump are 10⁻⁹ torr range. The

beamlines are evacuated from atmospheric pressure to high vacuum level with a particulate free, oil free turbomolecular pumping cart. 25 l/s shielded ion pumps distributed throughout the beamlines maintain the vacuum requirement. Due to the more demanding vacuum requirement of the injection beamline proximate to the e-gun, a vacuum bakeout of the injection beamline is required. In addition, two 200 l/s diode ion pumps and supplemental pumping provided by titanium sublimation pumps are installed in the injection line just beyond the exit of the e-gun. Due to expected gas load a similar pumping arrangement is planned for the beam dump. The cryostat vacuum thermally insulating the SRF cavities need only reduce the convective heat load such that heat loss is primarily radiation through several layers of multi-layer insulation and conductive end-losses which are contained by 5°K thermal transitions. Prior to cool down rough vacuum $\sim 10^{-5}$ torr range is established and maintained by a dedicated turbomolecular pump station. Cryopumping by the cold mass and heat shields reduces the insulating vacuum to 10^{-7} torr range after cool down.

The superconducting cavities are processed in particulate free environments to achieve the highest gradient possible. Dust particles can act as field emitters and limit the performance of the superconducting cavities. Therefore particles on the inner surface of the cavities need to be eliminated. Particulate must also be eliminated from adjacent components of the injection and loop beamlines to avoid particulate generation and migration into the SRF cavities. The particulate free requirement of beamline components represents the most challenging aspect to meeting the beamline vacuum requirements. A significant effort is focused on developing particulate free capability. Procedures and an on-site clean room processing facility at BNL were developed for processing new beamline components and QA of particulate processed components supplied by outside sources.

Electrons for the electron beam are generated by laser light illuminating a photocathode in the e-gun. The laser light is introduced to the beamline through a vacuum window in the injection beamline. The laser beam travels from the laser room to the photocathode through a transport line consisting of evacuated tube sections and a series of mirrors and lenses prior to entering the ERL injection beamline. Laser transport vacuum is established with a mechanical pump, maintained with a small ion pump and monitored with a vacuum gauge.

Pressure relief to protect both personnel and equipment has been incorporated into the warm and superconducting beamlines to meet the requirements of Section VIII of the Pressure Vessel and Boiler Code. Relief devices include spring loaded plates for cryostats and burst diaphragms for the beamlines. The SRF pressure relief devices are installed on the warm ends of the SRF strings. Cryostat and SRF beamlines relief devices are plumbed into vent headers to prevent an ODH condition in the ERL experimental area. Burst diaphragms installed on warm beamlines are vented directly into the experimental area because failure modes and conditions indicate an ODH 0 level can be maintained and the complexity of routing extra vent headers can be avoided.

2. ERL Vacuum Systems Configurations

2.1 Superconducting 5-Cell RF String Assembly

The schematic vacuum system of the ERL 5-cell RF cavity for Cold Emission Tests (CETs) is depicted in Figure 2. The system includes beamline and cryostat vacuum systems. The beamline vacuum is contained within the string assembly which includes the 5-cell cold mass operated at 2K and extends beyond warm-to-cold transitions and is terminated with electropneumatic gate valves. This entire string is built in an ISO class 5 clean room. A Gamma 20 l/s diode ion pump is installed on each end to maintain vacuum in the string when the cold mass is warm and provides some pumping of the warm ends during operation. HPS inverted magnetron cold cathode gauges installed on the downstream end and on the fundamental power coupler (FPC) monitor vacuum in the 5-cell beamline. The FPC gauges along with arc detection are used to protect the FPC from damage with RF power applied.

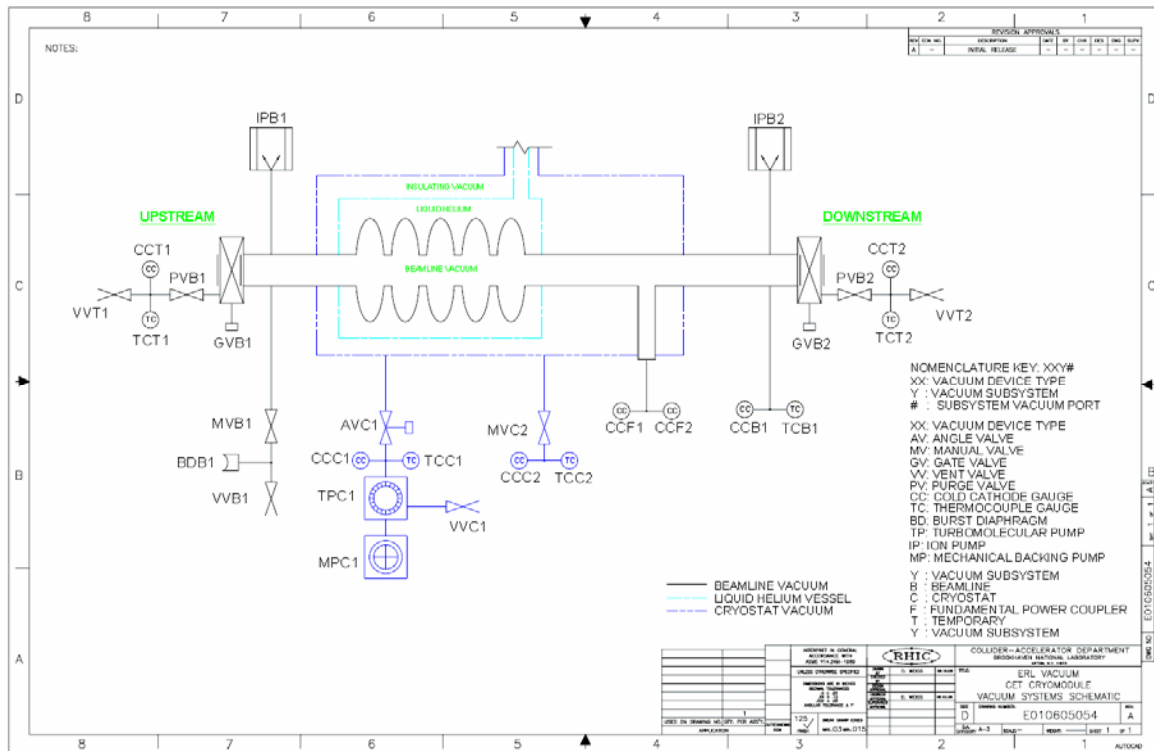

Figure 2. ERL 5-Cell Vacuum Systems Schematic

Centerline field probes are installed beyond the isolation gate valves for RF field and current measurements during CET. Temporary gauging installed beyond the isolation gate valves will provide the logic information to the valve control PLC to allow actuation of the gate valves during these CET tests.

Prior to cooldown vacuum is established and maintained in the 5-cell cryostat by a Varian 300 l/s turbomolecular pump (TMP) and backed by a 15 cfm 2-stage rotary vane

mechanical pump. A VAT right angle electropneumatic valve isolates the pump station from the cryostat. Gauging on the cryostat and at the TMP inlet provide the logic information to the vacuum control system to permit actuation of the isolation valve to open. The valve can be closed by user command at any point. TMP speed setpoint input provides the information to automatically close the isolation valve.

A suitable pressure relief device could not be developed and installed at JLab prior to hermetic string delivery to BNL. As a result, pressure relief was added to the beamline subsequent to delivery of the string assembly from JLAB. Due to the yield limitation of the niobium cavity, a special low pressure (5-7 psid) all metal burst disk was developed by BS&B for this application and shown in Figure 3. The over pressure condition resulting from a large LHe breach into the beam line and rapid heating from the warm ends indicated the need for two burst diaphragms to append the all-metal BTA isolation valve. Because these valves needed to be installed at BNL, additional manual all-metal valves, and a device to lock the original valves in the open position were required. With the cavity surrounded by a helium vessel at less than 1psia during operation, and the rupture disk exposed to atmospheric pressure the cavity would experience a pressure differential of 19.7-21.7 psig just before rupture of the burst disk.

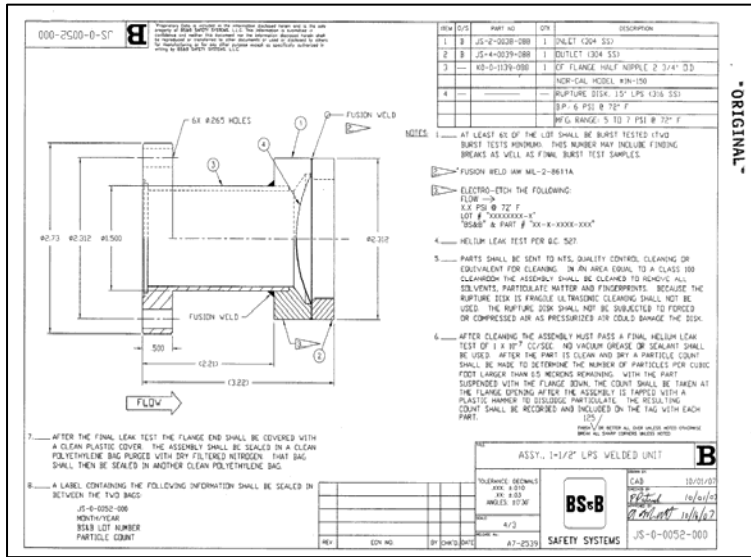

Figure 3. ERL 5-cell cavity Pressure Relief Device

Cryostat vacuum sealing is accomplished with ISO and Conflat type flanges. Room temperature regions of the beamline vacuum are sealed with Conflat type flanges. Vacuum sealing of the cryogenic region of the beamlines is more challenging. The cryogenic seal system provides low impedance RF contact as well as a vacuum seal against atmosphere and superfluid helium. The seals are made from an 1100 series aluminum alloy, namely AlMgSi0.5. The seals are machined with a hexagonal cross section with points along the sealing surfaces that are crushed to form the seal. The seals are rather stiff requiring over 8,000 pounds per inch of seal to compress adequately. The seal flange hardware consists of high strength A-286 alloy bolts and silicon bronze nuts torqued to 40 foot-pounds. No thread lubricant is required on the threads for this arrangement, which aids in the preservation of the required particle free environment.

Superconducting e-gun RF String Assembly

The vacuum systems of the e-gun are similar to the 5-cell. The e-gun includes beamline and cryostat vacuum systems and over pressure protection similar to the 5-cell. The beamline vacuum is contained within the string assembly that includes the single-cell cold mass operated at 2K and extends beyond warm-to-cold transitions and is terminated with electropneumatic gate valves. This entire string is built in an ISO class 5 clean room. A Gamma 60 l/s diode ion pump is installed on the upstream end to maintain vacuum in the string when the cold mass is warm and provides pumping of the e-gun backside and the photocathode transport cart and transition during operation.

The e-gun is integrated with the photocathode transport cart such that the beamline vacuum becomes common when the cathode is inserted from the cart to the gun. A load lock volume between the 2 chambers must be evacuated and satisfy logic in the vacuum control system before the e-gun valve can be actuated open. These valves feature an impulse solenoid design that essentially latches the valve open even under power failure and pressure loss conditions. Some consideration was given to requiring manual operation of this valve to protect the e-gun cathode receptacle and cavity by insuring that the valve could not close on the cathode stalk when the cathode is inserted in the receptacle in the e-gun. Limit switches and locking keys form part of the photocathode transport system to resolve this concern.

Cryostat vacuum is established and maintained with a TMP system identical to that of the 5-cell. The schematic for the TMP system and remote integration is shown in Figure 4.

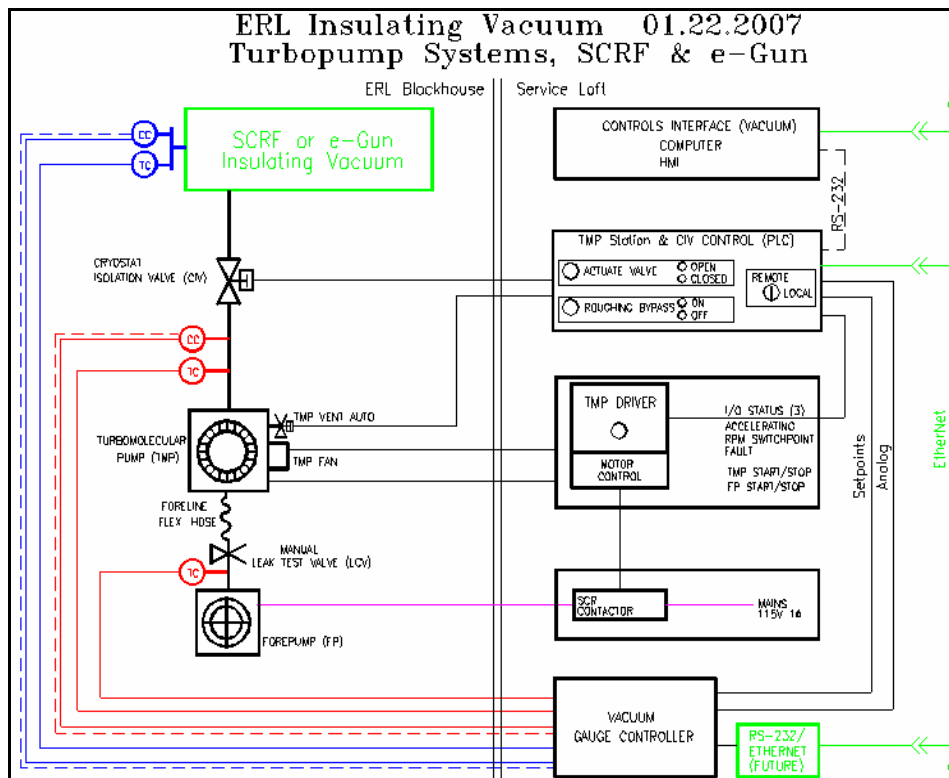

2.2 Electron Loop

The electron loop environment is entirely room temperature. The beamline is composed of dipole and quadrupole magnet chambers, drift chambers and various beamline components. Vacuum components include ion pumps, gauges and valves. All magnet chambers are made from non-magnetic materials to adhere to the strict magnetic field requirements. Dipole magnet chambers are made from aluminum. Ease of machining and low outgassing rates when processed properly are added benefits of using aluminum. Results of outgassing measurements performed with a baked 1st article aluminum dipole chamber reveal rates of low 10^{-12} torr-liter/sec-cm². This result compares favorably with clean, baked stainless steel material. The dipole chambers were built by Atlas Technologies. A dipole chamber is shown in Figure 5.

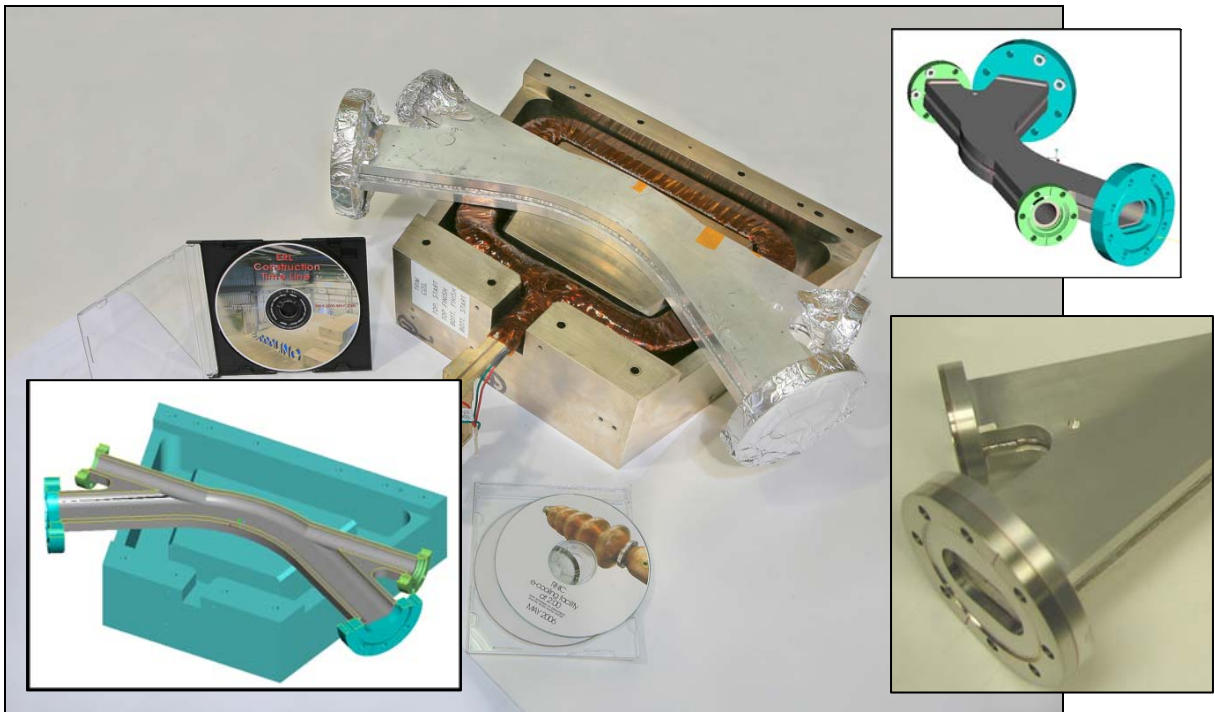

Figure 5. ERL Loop Dipole and Dipole Chamber

Dipole chambers are machined as $\frac{1}{2}$ cores and externally welded together. The weld is not full penetration to keep the chamber inner surface smooth. The proprietary weld prep maintains a smooth chamber ID profile without trapping volume. Atlas explosion bonded bimetal Conflat type flanges are welded to the chamber assembly allowing standard Conflat gasket and hardware to interconnect mating beamline components.

Chambers passing through quadrupoles are made from inconel tube. A quadrupole chamber is shown in Figure 6. The magnetic permeability of the quad chamber inconel beam tubes is less than 1.01. The remainder of the quadrupole chamber is made from

304L stainless steel. Hydroformed bellows that form part of each quadrupole chamber are made from inconel. The quadrupole chambers were built by MDC.

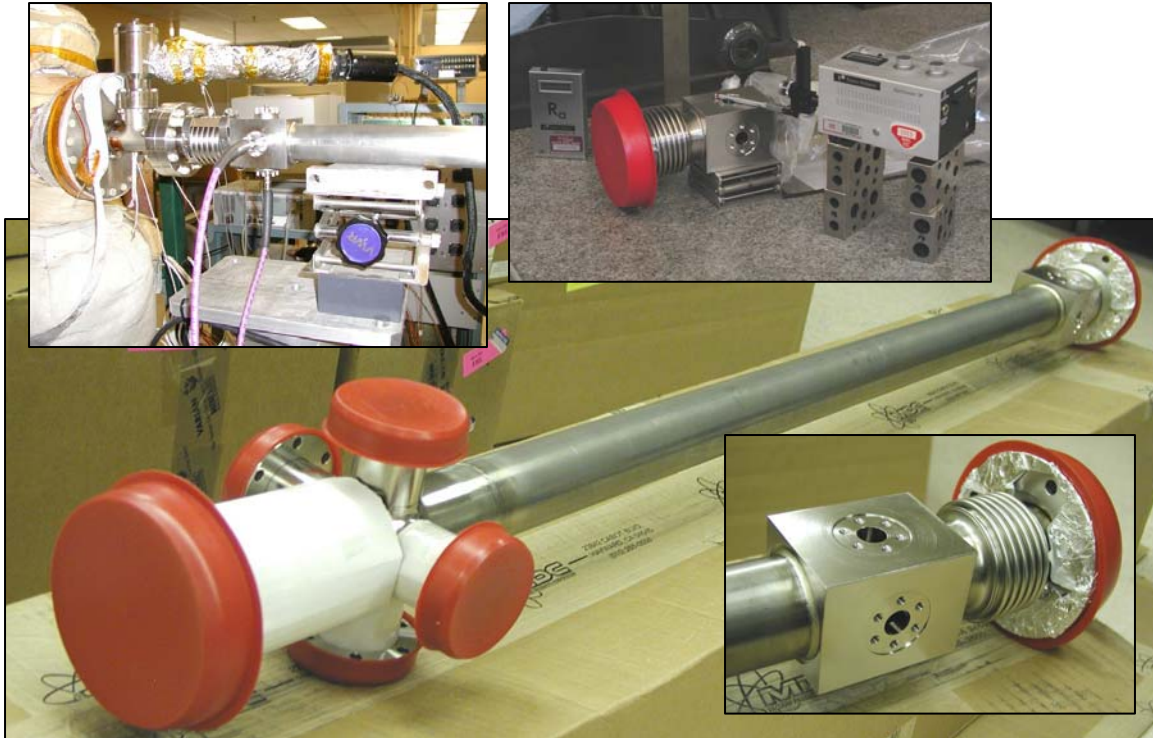

Figure 6. ERL Loop Quadrupole Chamber with BPM Cube

Vacuum gauging and pumps are all mounted on crosses at the end of quadrupole beampipes. In addition button beam position monitor (BPM) cubes are integrated with the quadrupole chambers. BPM buttons are installed in the cubes. The BPM cube incorporates the primary chamber mount. The cube dimensions are controlled to very tight tolerances for positioning the bpm buttons such that beam based alignment techniques are not required. The dipoles quadrupoles and associated beam pipe supports are pinned to a tightly toleranced strong back to insure the precision of the BPM buttons to the magnets and beam centerline.

A complete assembly of magnets and chambers installed on a strong back otherwise known as a triplet assembly (3 quads) is shown in Figure 7. The chambers are interconnected with 4-1/2 inch Conflat type flanges. The cross ports for gauging and beam components are either 2-3/4 inch or 4-1/2 inch Conflat flanges.

The BPM buttons are sealed to the BPM cube with Helicoflex delta seals. The seal groove is machined into a mini-Conflat (1.33 inch) bolt circle. The sealing force, less than a comparable Conflat seal, insures an even metal-to-metal interface between button and cube. This lower compressive force seal helps maintain the precision placement of the button relative to the beam centerline with more uniform contact between the machined face of the BPM cube and that of the BPM button flange. The seal has an aluminum jacket that limits bakeout temperature to 150°C.

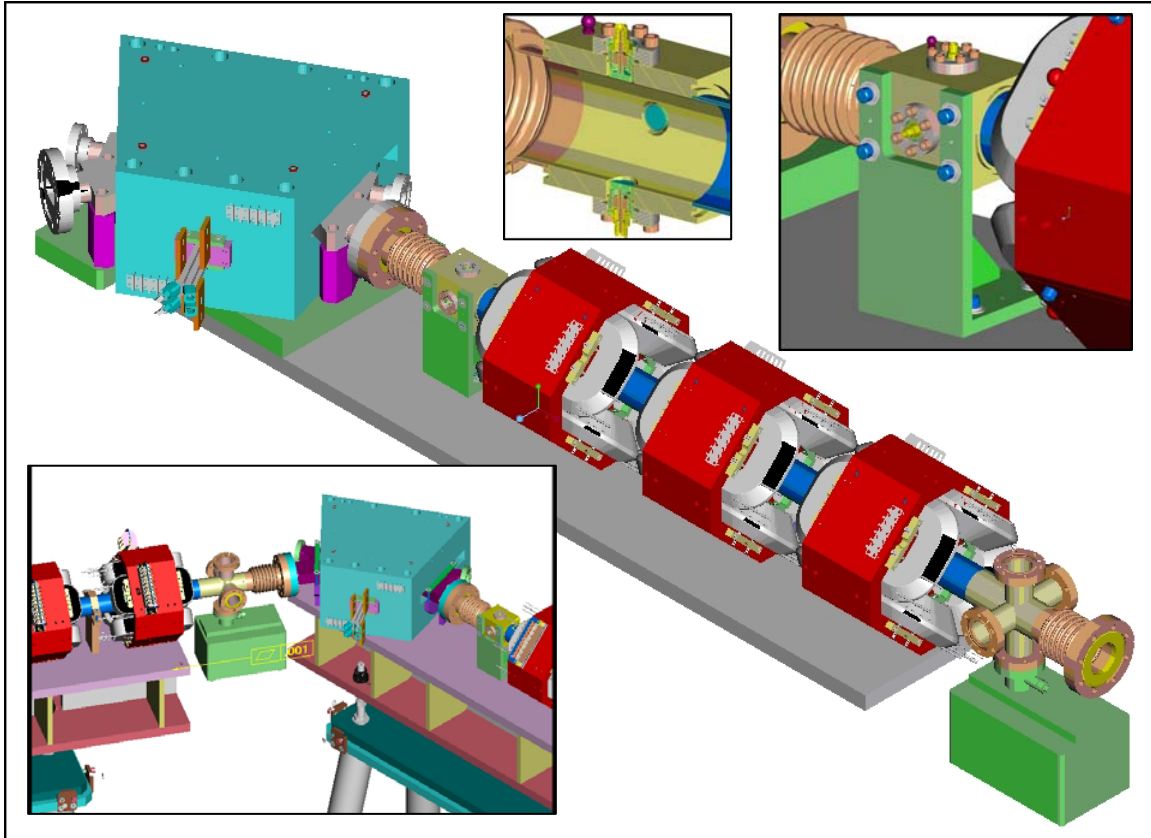

Figure 7. ERL Loop Triplet Assembly

2.3 Injection

The electron beam generated at the photocathode of the e-gun travels to the accelerating 5-cell RF cavity through the injection line. The injection beamline for ERL is configured in a vertical zig-zag to merge with the loop beamline passing into 5-cell. The ERL zig-zag injection line uses a bend system for merging the fresh low energy injection beam and the high energy circulated beam. Prior to a full ERL installation with the loop, an intermediate injection line configured as a straight pass will be installed as a convenient means of integrating and testing the e-gun and 5-cell cavities. This intermediate configuration is referred to as Gun to 5-cell (Gt5) test.

The ERL zig-zag design has matured to a point such that magnets could be manufactured. Magnet chamber designs have also been developed, but have not progressed through checking and release. This firm lattice includes placement of various beam diagnostic components along its length. Attention was then shifted to the design of the Gt5 injection line as this milestone is obviously earlier than the full ERL with zig-zag injection line.

As a result, the vacuum component layout for the Gt5 vacuum beamline is complete and the ERL zig-zag injection line requires an update. Figure 8 depicts the Gt5 injection beamline. Figure 9 depicts the ERL zig-zag beamline. Both injection line vacuum systems are constructed with features similar to the ERL electron Loop.

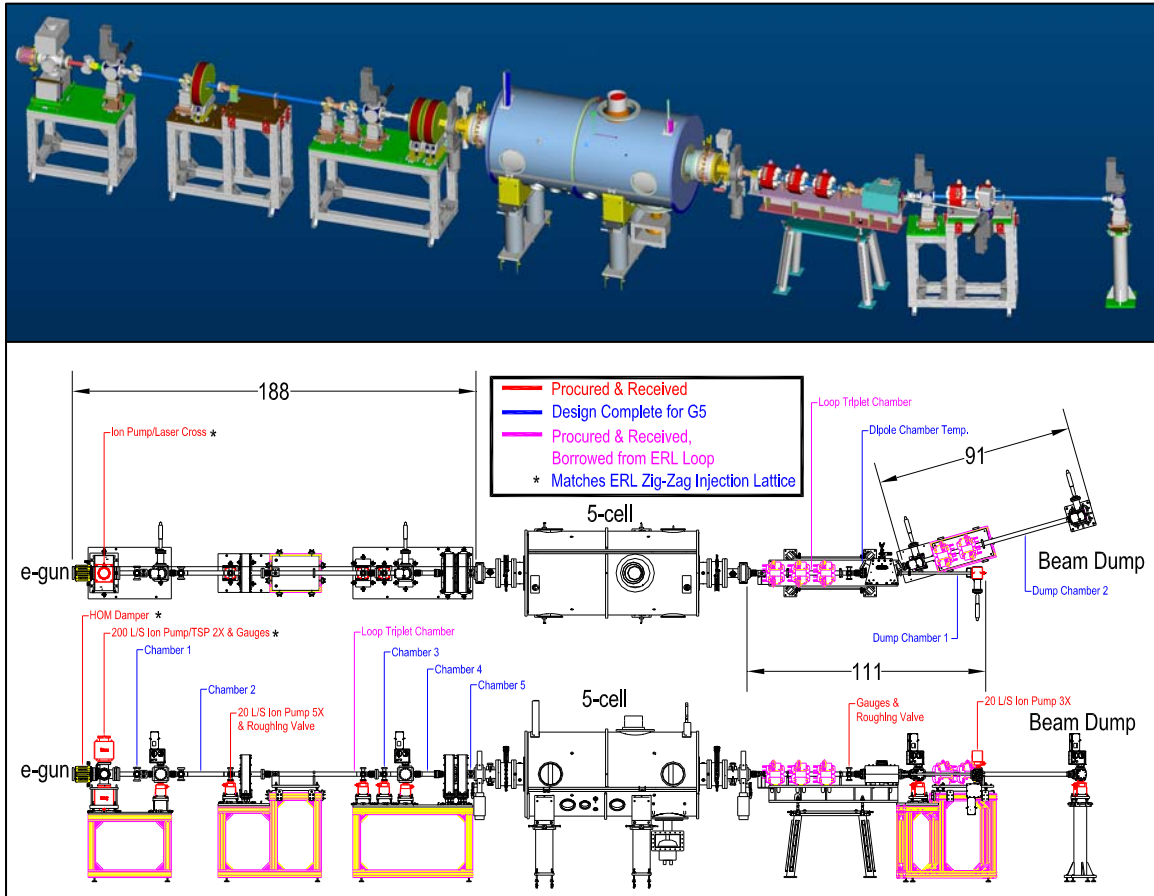

Figure 8. Gun to 5-Cell (Gt5) Injection Beamline

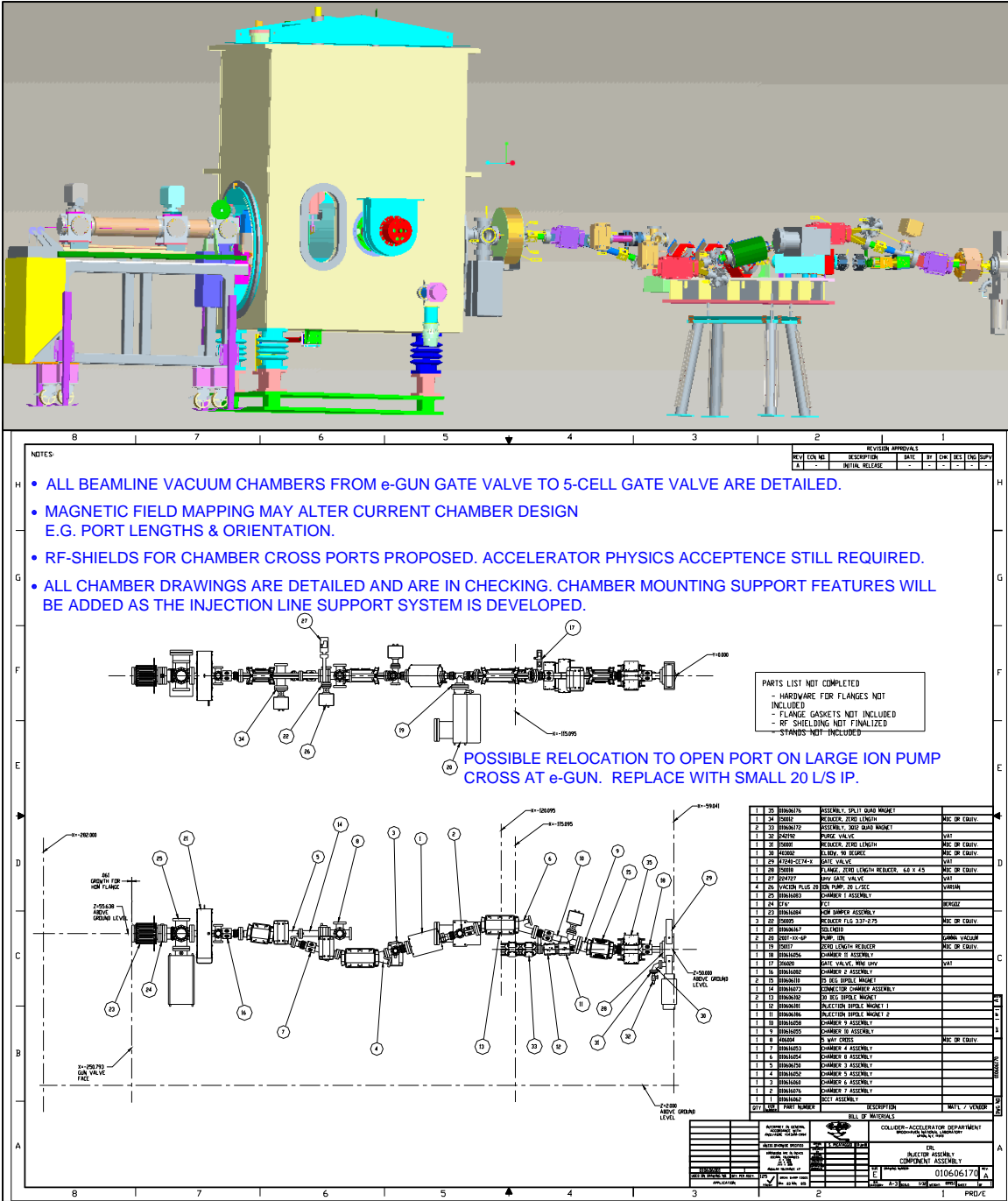

Figure 9. ERL Zig-Zag Injection Beamline

The two distinct differences in requirements between the loop and injection beamlines are the injection line requirement to be baked at 150°C and rf-shielding of bellows and unpopulated instrumentation ports. The bakeout requirement is specified to protect advanced design photocathodes from poisoning, which could result from exposure to pressures above 10⁻¹¹ torr. This cathode protection requirement also resulted in a shift in the pumping arrangement. This shift results in a second large 200 l/s ion pump placed at

the exit of the gun. In addition, these ion pumps are supplemented with titanium sublimation pumps. The chamber pumping ports were also shortened to maximize pumping speed for both large and small ion pumps. To eliminate the influence of magnetic fringe fields from ion pumps on the beam, the large ion pumps were changed from dipole to quadrupole magnet configuration and the small 25 l/s ion pumps were purchased in the magnetically shielded configuration. These modifications are complete in the Gt5 and remain to be incorporated in the ERL zig-zag.

RF-shielding is specified for the ERL zig-zag as the low-energy beam at injection is more susceptible than the accelerated loop beam to beamline impedance. Where practical the Gt5 will also include RF-shielded features. Capacitive type shields span the convolutions of hydroformed bellows of the zig-zag and GT5 chambers also used on the zig-zag. Unpopulated instrumentation ports on both injection beamlines will include wire grid RF-shielding. The grids are installed on plugs on blank flanges and slid into the unpopulated ports and sealed. This removable shield design adds flexibility to the beam components placement in the injection line. Fixed wire grids will form part of each permanently allocated zig-zag pump port, including the pump ports of the laser/ion-pump cross. The laser/ion-pump cross will also be used on the Gt5 beamline.

Most other features from materials to seal technology are identical between the injection lines and the loop. However, dimensional control is not as strict in the injection beamline. Although the BPM blocks are essentially identical designs they are not required to provide the absolute chamber position as they are in the loop chambers.

2.5 Laser Transport

Laser light travels from the laser room through a series of windows tubes mirrors and windows and into the injection beamline where an in vacuum mirror positioned in the laser/ion-pump cross directs the laser light to the photocathode. The laser transport line protects the path of the laser light by providing a rough vacuum in the laser path between the optomechanics. Figure 10 diagrams a 3-view layout of the Laser transport line.

Clean Ø1-1/2 stainless steel tubing terminated with 2-3/4 Conflat flanges and sealed with optical vacuum windows provides the vacuum envelope for the transport line. The sections of the transport line interrupted with optomechanics are bridged with flexible tubing to establish a single vacuum volume. The line is pumped down to a rough vacuum and monitored locally with a capacitance manometer gauge and controller located in the laser room. Periodic roughdown of the line will be performed when pressure exceeds some predetermined value. Alternatively, an ion pump will be installed to maintain the vacuum in the transport beamline.

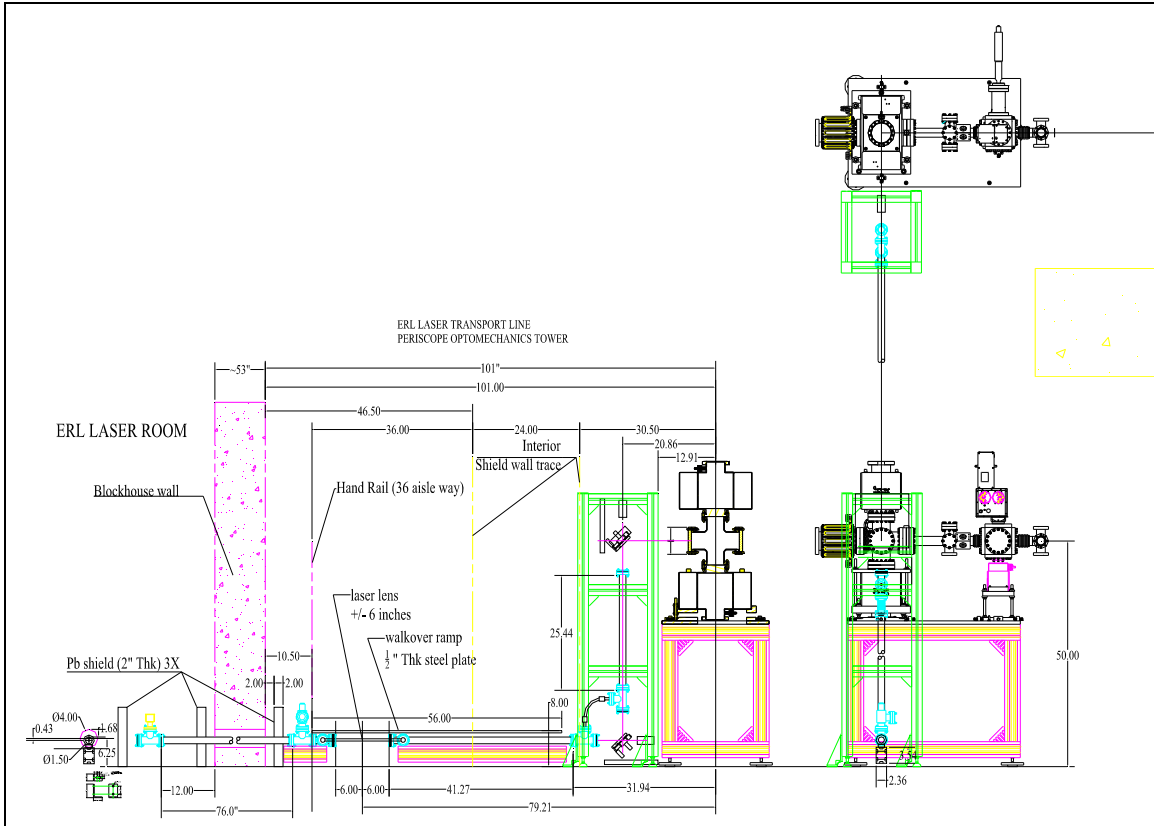

Figure 10. ERL Laser Transport Layout (3-view)

3.0 Vacuum Instrumentation & Control

The architecture for the vacuum systems instrumentation and control is shown in the block diagram of Figure 11. The ERL vacuum control is accomplished using Allen-Bradley ControlLogix and MicroLogix programmable logic controllers. The ControlLogix PLC has 3 primary functions:

- Valve control: Close valves on vacuum fault and provide logic for opening valves (sector valves or pump isolation valves)
- Generate beam permits and other equipment interlocks
- Communicate vacuum system valve status and vacuum data with end users through the front end computers and UNIX/LINUX workstations via Ethernet.

Based on a ladder program with discrete inputs, the PLC determines whether a vacuum valve can be opened or if it must be closed. Relay setpoints from the gauge and ion pump controllers, with sector valve position indicator status is used to determine the vacuum system status. The PLC reacts to the inputs to close the sector valves in the event of a vacuum problem, and prevents sector valves from opening if certain conditions are not met. Beam permits are active if all sector valves are open. Equipment interlock signals can be customized for other subsystems such as RF. The ControlLogix PLC will transfer valve, interlock, and beam permit status to the Controls System through Ethernet communication.

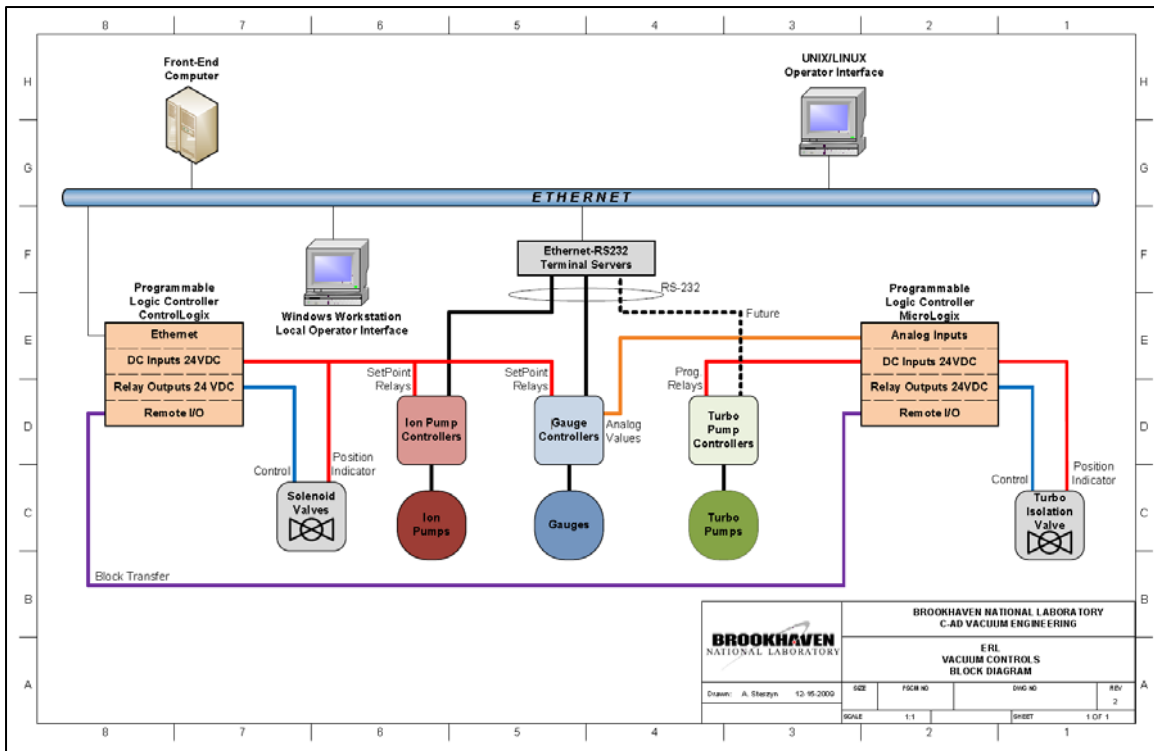

Figure 11. ERL Vacuum Instrumentation Control System Architecture

Controllers for vacuum gauges, ion pumps, and eventually turbopumps, communicate with end users through the front end computers and UNIX/LINUX workstations. Remote monitoring and control of these devices is accomplished using Digi TS-16 Ethernet terminal servers that provide the connection between the vacuum controllers and the Ethernet network.

Turbopump systems responsible for pumping on the e-gun and 5-cell cryostats are currently controlled by independent Allen-Bradley MicroLogix 1100 PLCs. Analog inputs from the gauges and discrete inputs from the turbo controller are used to control the valves that isolate the turbopumps from the system. Block data transfer from the MicroLogix controller to the ControlLogix controller will provide end users with TMP Station information and control. An alternate integration eliminating the MicroLogix may be implemented in the final turbo control configuration. In this case, any I/O currently assigned to the MicroLogix controller will be reassigned to ControlLogix I/O, and the corresponding ladder logic moved to the ControlLogix controller. The change would be transparent to end users.

A man machine interface (MMI) will provide direct access through the Ethernet to the vacuum system PLCs and controllers. The MMI, a windows workstation, resides with all vacuum PLCs and vacuum controllers in three racks in the mezzanine outside the ERL blockhouse. A diagram of the vacuum rack layout is shown in Figure 12.



Figure 12. ERL Mezzanine Vacuum Instrumentation Control Rack Layout

UNIX/LINUX operator interfaces allow users to monitor and control ERL vacuum system devices. The vacuum system data is displayed on PET pages. The 5-cell vacuum gauge PET page is shown in the Figure 13.

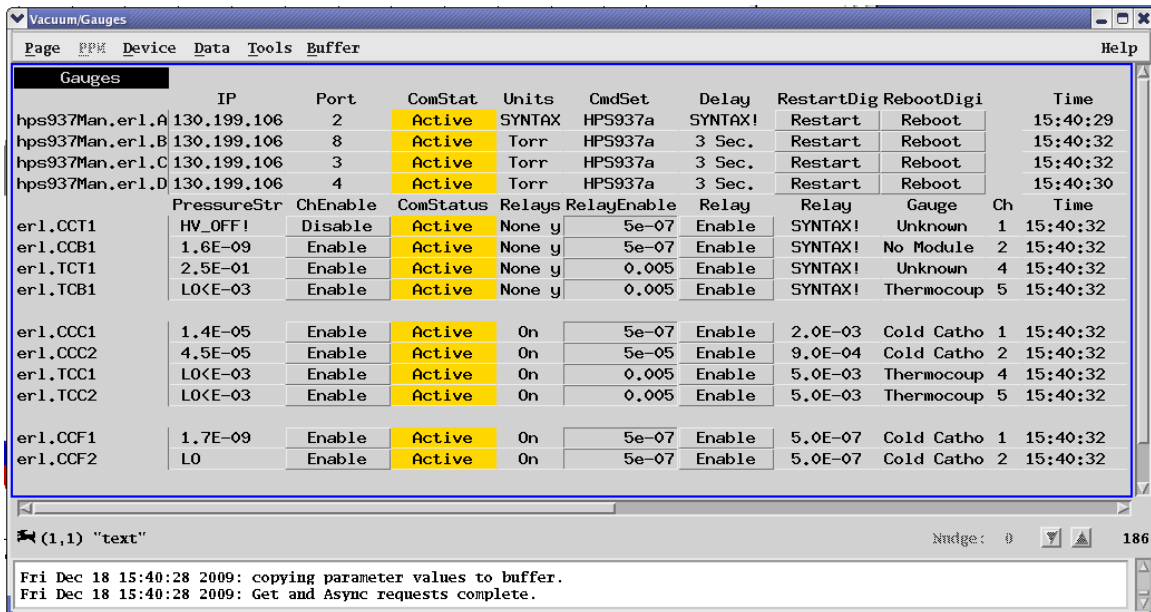

Figure 13. ERL Vacuum Instrumentation Remote Operation, 5-Cell Vacuum Gauge PET Page

4.0 Installation & Assembly

Due to the sensitive nature of the superconducting RF cavities to particulate, special cleaning, handling, assembly and installation techniques are required for all beamline components. The general process flowchart required for all components installed in the ERL beamlines is shown in Figure 14.

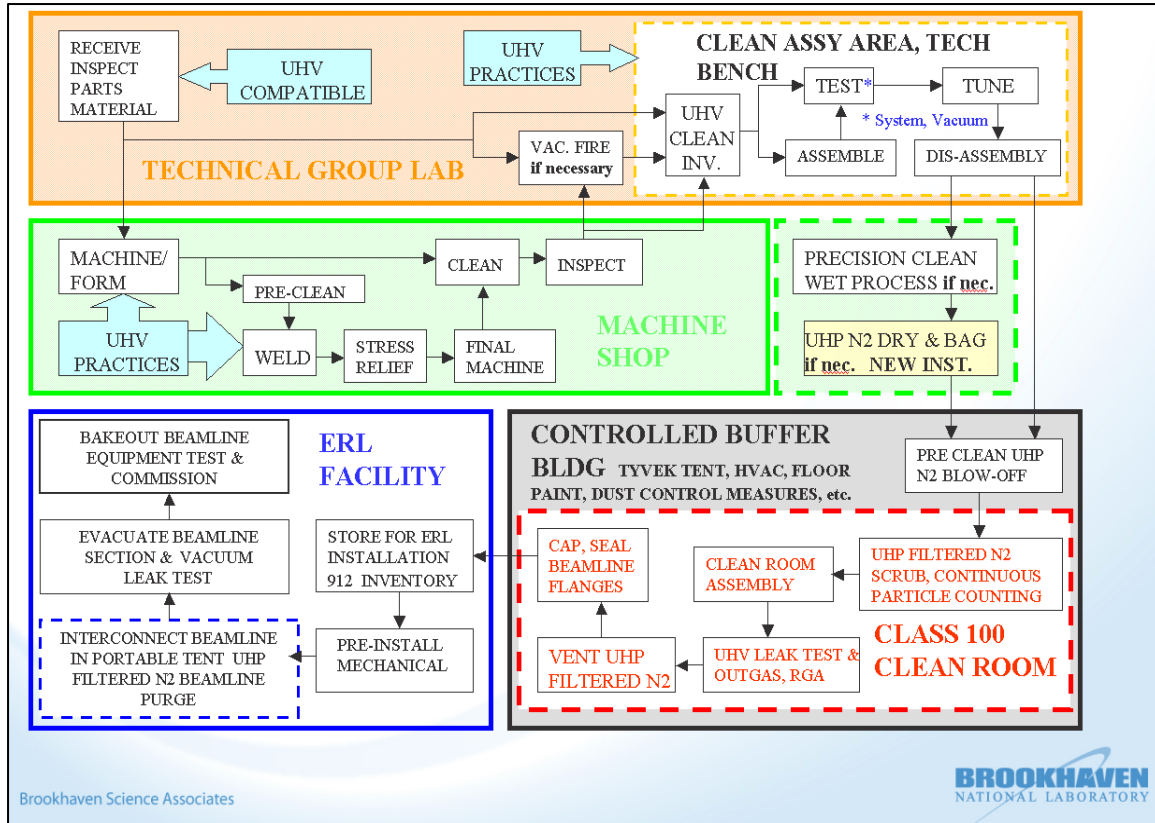

Figure 14. ERL Beamline Vacuum Component Process Flowchart

Components destined for the ERL beamline are either delivered to BNL or processed at BNL for suitability of service in an ISO 14644 Class 5 clean room. This processing includes vacuum flange seals and hardware. Components delivered Class 5 ready are double bagged and are only opened in a Class 5 environment. All QA is performed in the class 5 environment. If QA outside the Class 5 environment is needed, then re-processing for particulate free service is needed. So, careful attention and coordination is needed to avoid costly re-work if at all possible.

All chamber subassemblies are completed in the clean room and double bagged. This includes the installation of vacuum gauges, BPM buttons and any other small beamline components. All vacuum ports are populated or blanked-off at this stage if possible. The beamline ports are covered to protect against particulate infiltration. Only the beamline vacuum ports are left unsealed, as this is the final step for installation of the chamber in the beamline. Subsequently, these partially completed chamber assemblies are installed

in the magnet assemblies. Chamber interconnections and remaining beam components and ion pumps are installed in the ERL blockhouse. Once in the blockhouse, components are assembled on to the beamline inside a portable Class 5 environment. In addition to the beamline components, seals and hardware, all tools, equipment, technician wardrobe etc. needed to complete the beamline must also be processed for the Class 5 environment. The process of introducing the materials into the portable clean room must be done slowly and methodically to avoid disturbing and contaminating the assembly zone with particulate. With the outer bag removed just outside the tent a nitrogen blowdown of the second bag is made before bringing the bag into the tent. The second bag is opened only after the particle counter indicates the particulate level meets Class 5 requirements.

Ultra high purity, sub-micron filtered nitrogen gas is introduced into the beamline at a port near the superconducting cavity. The gas is expelled at the beamline joint being assembled. This process provides a positive pressure profile away from the superconducting rf cavity to keep any particulate generated during the installation from migrating toward the cavity. Any particulate generated during this process will be flushed from the beamline at the beamline vacuum joint being assembled. The portable cleanroom must be moved and set-up at several locations to complete the beamline installations. Following relocation of the tent, several hours to a couple of days, is required to re-establish the Class 5 environment required to continue the installation. Installation effort inside the portable clean room tent is shown in Figure 15.



Figure 15. ERL Beamline Assembly Inside Portable Clean room

Once the beamline installation is complete, the beamline is pumped down with a particulate free TMP cart and leak checked. Preparations for bakeout are made for the injection beamline, otherwise pumping is transferred to the ion pumps and the beamline commissioned for service.

5.0 Research and Development Efforts

5.1 Particulate Processing

The ERL project has brought with it new challenges in particulate free assembly techniques. Existing BNL accelerators have stringent UHV requirements, but not the sensitivity to particulate contamination that accompany superconducting RF cavities.

While the 5-cell as well as the e-gun will be delivered as a particulate free hermetic string, it is BNL's responsibility to fabricate and install the associated beam lines in a particulate free manner. An existing clean room was refurbished to support the particulate free processing of components for ERL. This clean room was used to fabricate detector components for the PHENIX detector of RHIC. Located within the large clean room is a 10'x10' class 100 soft wall which houses a laminar flow bench. Figure 16 shows a layout of the clean room and particulate free processing facility.

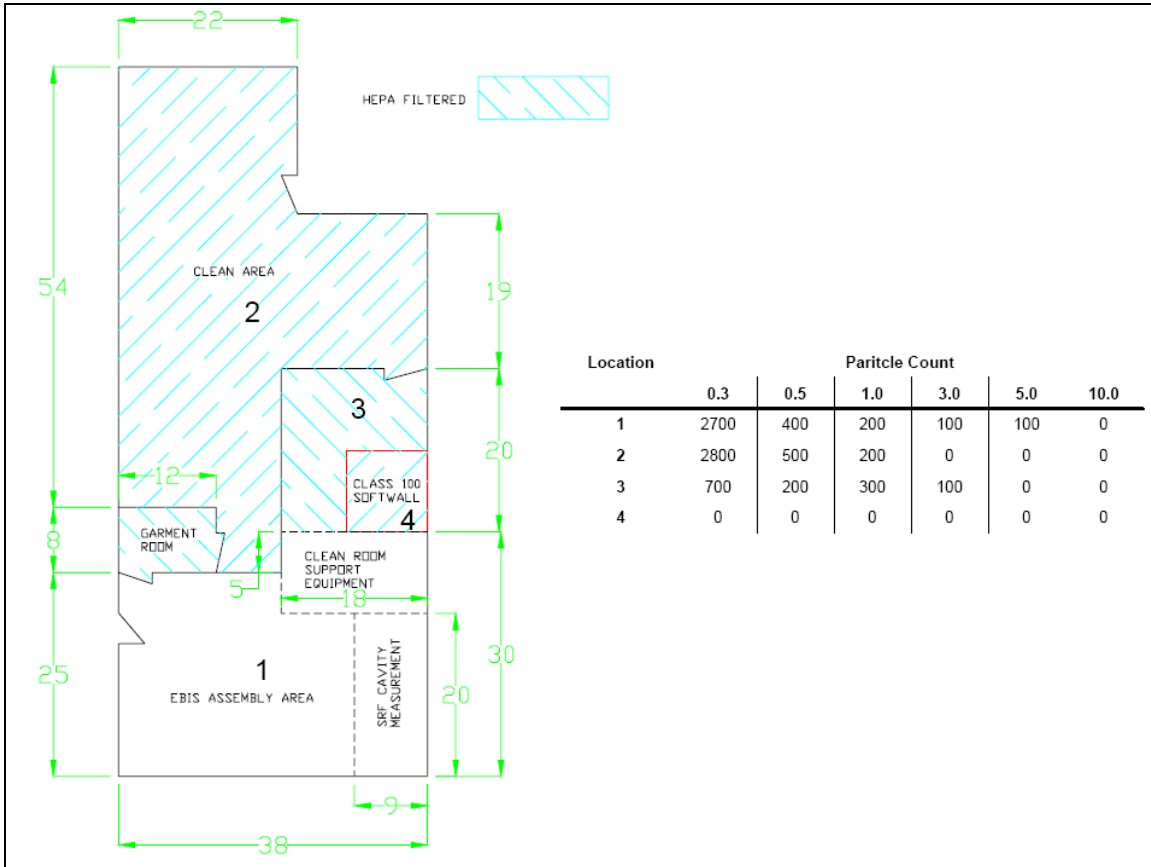

Figure 16. Clean room and particulate free processing facility layout.

This space was used to process the burst disk component assemblies installed on the 5-cell cavity. The components were blown down with .003 micron filtered nitrogen and monitored with a particle counter until no counts were observed. For installation on the 5-cell cavity, a portable, class 100 downdraft clean room was erected at the end of the 5-cell. The assemblies were double bagged and transported to the 5-cell for installation. Figure 17 shows a schematic for the particulate free installation of the burst disk and the final configuration showing reinforcement rods and vent header pipe.

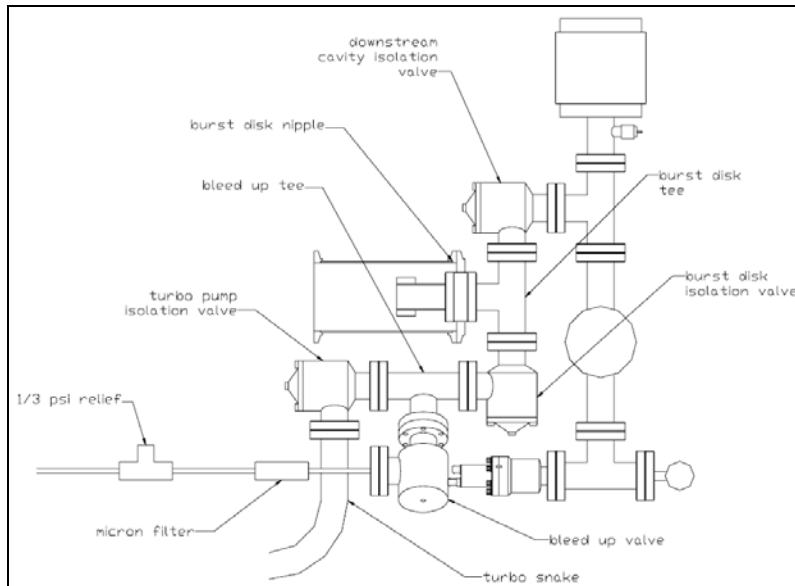

Figure 17. Particulate free installation of the burst disk.

Inspections revealed some UHV cleaned components required wet processing due to size and geometry. An ultrasonic cleaner is also located within the clean room to clean these components.

5.2 SRF Bakeout

To improve the Q, the cavity was subjected to a mild bakeout. Due to concern over the cavity to thermal transition vacuum seals, the temperature was limited to 120°C. Liquid nitrogen was vaporized, heated with cartridge heaters and passed through the titanium LHe fill line of the cryo cavity. The hot gas exhausted at the top of the cryomodule. The cryomodule was wrapped in nomex insulation and the FPC was heated with conventional heating tape. The bakeout was controlled with the RHIC Bakeout Cart which uses PID controllers. Figure 18 shows a picture of the string assembly prior to bakeout and the control page of the bakeout system.

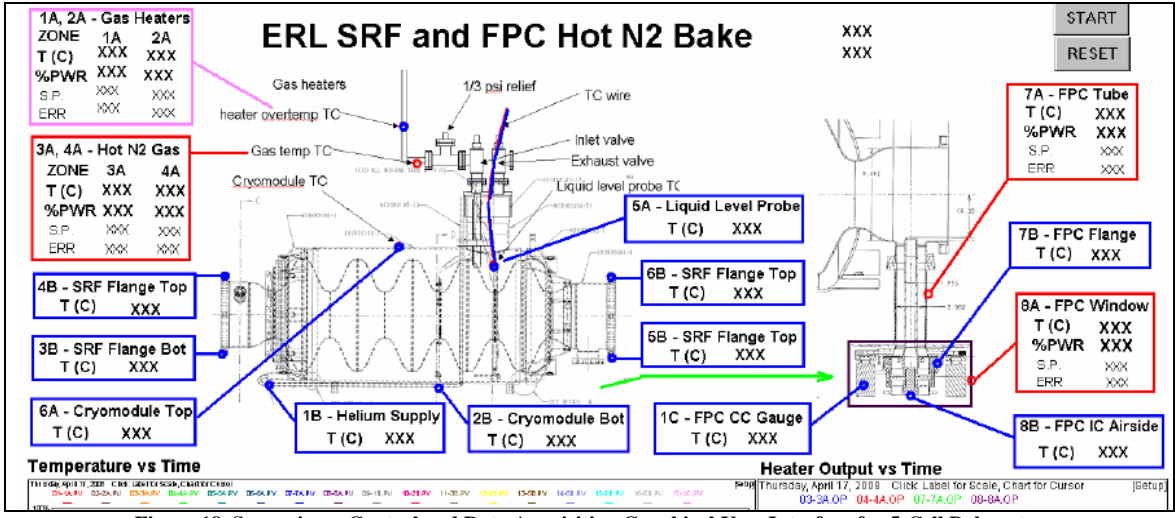

Figure 18. Supervisory Control and Data Acquisition Graphical User Interface for 5-Cell Bakeout

5.3 Cold Emission Testing (CET)

There have been three CET's of the 5-cell. A vacuum summary of the first test is shown below. The beam vacuum and cryostat vacuum behaved as expected upon cooldown. Pressure spikes were evident when RF power was put on the cavity. Additional CET's have shown that the cryostat turbopump system does not contribute to unwanted cavity microphonics.

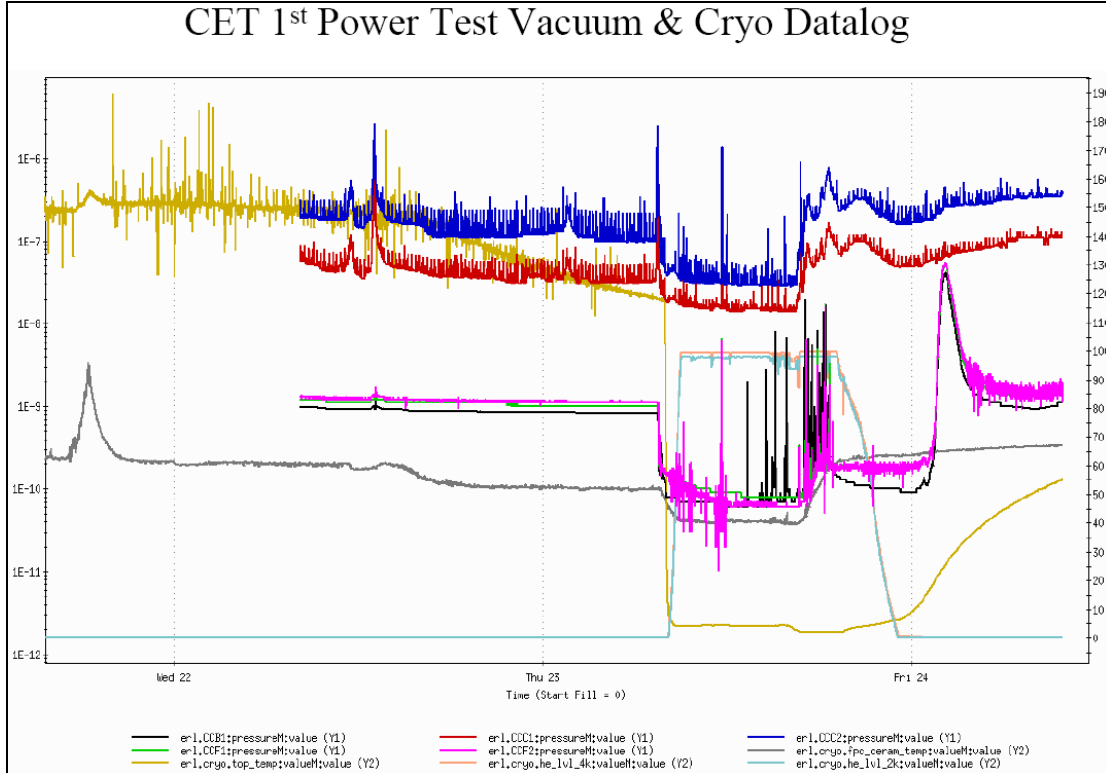

Figure 19. Vacuum and Cryogenic Temperature Trend during first Cold Emission Test (CET)

5.4 Helium Processing

The 5-cell has reached its design gradient of 20 MV/m, but with unwanted radiation emission. A helium introduction system was installed on the beam line. Research grade 99.9999% helium is passed through a purifier and 0.003 micron filter before being introduced to the cavity through a all metal variable leak. This system requires local access to the cavity for adjustments in pressure. During helium processing, it was found that the frequency of the cavity was unstable and frequent adjustments in pressure were required. To improve this process by not requiring RF power to be taken off the cavity for local access, the helium system will be made remote operational by controlling the variable leak with Selsyn (self synchronous) motors. This approach will allow the existing system, which required significant clean room processing to install, to remain hermetically sealed and intact. Figure 20 shows the helium introduction system prior to installation of the remote controlled variable leak with pulley & drive belt and control valve on turbo pump inlet. Alongside are views of the cavity receive synchro with pulley and the control room transmit synchro with remote control interface.

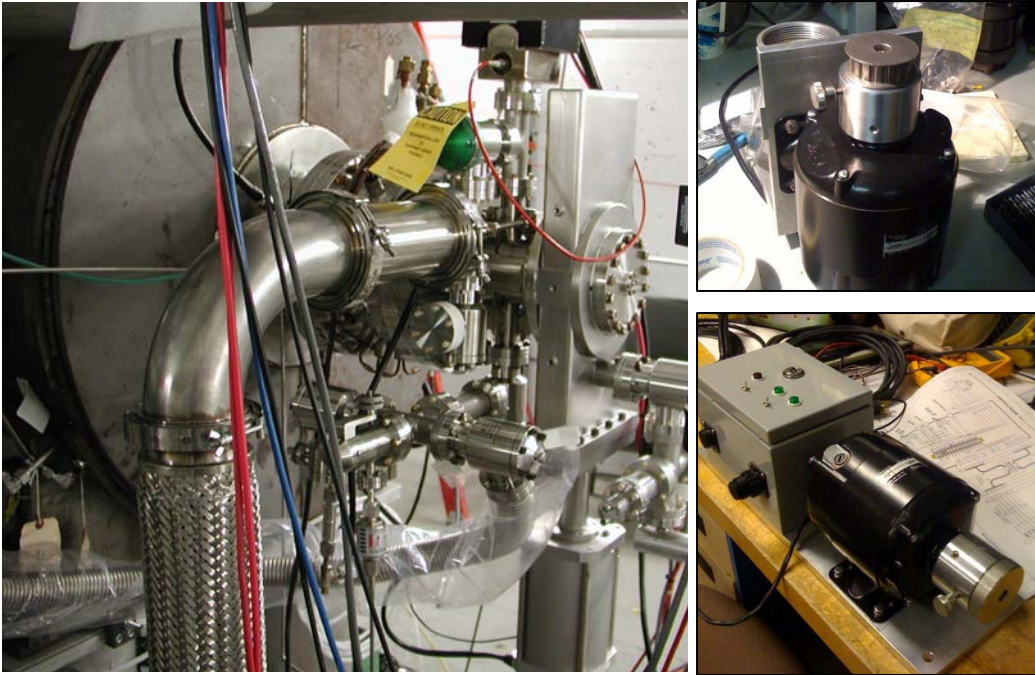

Figure 20. Remote Helium Processing System for ERL 5-Cell

Self synchronous motors are also known as selsyn or synchro motors. The two motors, transmit and receive, are separated by electrical cable. The three stator winding taps and the two rotor taps are individually connected together. Common single phase 115VAC 60Hz is placed on the rotors. The rotation of the transmitter motor will cause a like rotation in the receiver motor with torque transmission and feedback. An interface box is mounted next to the transmit synchro which resides in the control room. This provides an inlet for the 115VAC, connection to the remote synchro receiver, synchro power on/off and the ability to open/close an isolation inlet valve on the turbo pump cart for He cleanup.

5.5 Diamond Amplified Photocathode Development

The use of diamond to amplify cathode electron emission is being investigated. The development of such a cathode will require continuous vacuum levels of 1×10^{-11} Torr for CsKSb and 1×10^{-9} Torr for other cathode materials. To maintain such vacuum levels during operation, the electron and x-ray desorption rates must be investigated and a suitable NEG capsule developed to maintain pressure both warm and when in operation. A prototype NEG cartridge was fabricated and base pressure tested to 9×10^{-11} Torr. Preliminary measurements in the lab show x-ray desorption to be a problem at higher primary energy ranges.