



Brookhaven
National Laboratory

BNL-99493-2013-TECH

C-A/AP/344;BNL-99493-2013-IR

Cryogenic and Cryostat System for the 56 MHZ SRF Cavity

R. Than

January 2009

Collider Accelerator Department
Brookhaven National Laboratory

U.S. Department of Energy

USDOE Office of Science (SC)

Notice: This technical note has been authored by employees of Brookhaven Science Associates, LLC under Contract No. DE-AC02-98CH10886 with the U.S. Department of Energy. The publisher by accepting the technical note for publication acknowledges that the United States Government retains a non-exclusive, paid-up, irrevocable, world-wide license to publish or reproduce the published form of this technical note, or allow others to do so, for United States Government purposes.

DISCLAIMER

This report was prepared as an account of work sponsored by an agency of the United States Government. Neither the United States Government nor any agency thereof, nor any of their employees, nor any of their contractors, subcontractors, or their employees, makes any warranty, express or implied, or assumes any legal liability or responsibility for the accuracy, completeness, or any third party's use or the results of such use of any information, apparatus, product, or process disclosed, or represents that its use would not infringe privately owned rights. Reference herein to any specific commercial product, process, or service by trade name, trademark, manufacturer, or otherwise, does not necessarily constitute or imply its endorsement, recommendation, or favoring by the United States Government or any agency thereof or its contractors or subcontractors. The views and opinions of authors expressed herein do not necessarily state or reflect those of the United States Government or any agency thereof.

Cryogenic and Cryostat System for the 56 MHZ SRF Cavity

R. Than



**Collider-Accelerator Department
Brookhaven National Laboratory
Upton, NY 11973**

Notice: This document has been authorized by employees of Brookhaven Science Associates, LLC under Contract No. DE-AC02-98CH10886 with the U.S. Department of Energy. The United States Government retains a non-exclusive, paid-up, irrevocable, world-wide license to publish or reproduce the published form of this document, or allow others to do so, for United States Government purposes.



**CRYOGENIC AND CRYOSTAT SYSTEM
FOR THE 56 MHZ SRF CAVITY**

**Cryogenics Systems Group
Collider Accelerator Department
R. Than**

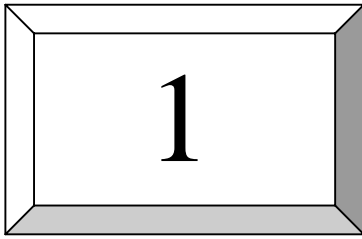

SYSTEM CONFIGURATION

1.1 Configuration

System Level Configuration (Figure 1)

Liquid helium is taken from RHIC's main helium headers to supply liquid helium to the cavity system. Because of the low design pressure of 20 psia (~5 psig) and pressure stability concerns for the cavity, the boil-off cannot return to the RHIC's main cold vapor return line (R-Line), which would provide the most efficient operating configuration. Instead, the boil-off vapor is return to a small local compressor that will re-inject the helium back to the main warm return header to the main cryo plant. A refrigeration recovery heat exchanger system can be implemented, to decrease the load on the cryo plant by converting the liquefaction load to a refrigeration load. The refrigeration recovery high pressure cold gas is returned to RHIC's cold vapor return header. The transfer line heat load from the RHIC main to the cryostat is removed in a separate phase separator (#1) and this vapor is return back to RHIC main cold vapor return.

Liquid Helium Supply

Liquid helium can be taken from two of RHIC's main cryogen headers, the S or M headers. Although liquid helium supply from the M header is more stable in temperature than the S-header, tie-in with the S header is a lower risk task than tie-in with the M-header because of the superconducting bus running through the M-header. Because of mechanical and flow induced pulses in the liquid helium supply, the supply pressure in RHIC's main headers exhibits variation of approximately 0.75 psi at several frequencies below 20 Hz.

Transfer Line System

A 1/2" line tap from the S-header (main supply header to RHIC coolers) will supply helium to the cryostat system and the a 1" cold vapor return line will take vapor from the 1st separator and recovery coldbox back into the R header, RHIC main cold vapor return header.

Cryostat System (Figure 2)

First Separator (#1)

The system consists of a first separator that takes the 3.5 - 4 atm, 4.6K RHIC liquid helium and flashes it down to 1.5 atm or a pressure sufficient to provide a reasonable pressure drop through the thermal transition intercepts. The vapor from the first separator is returned to RHIC's cold vapor return header, the R-header. The 1st separator serves to isolate the pressure pulses from the RHIC's liquid supply lines, and is where the heat load from the transfer lines is removed. Liquid from the 1st separator supplies the condenser loop's separator (#2) and also the flow to the heat intercepts on the thermal transition pieces, and fundamental damper wall.

Condenser/Boiler Loop (Separator #2 and Condenser)

The condenser heat exchanger is located in the cavity-cryostat's upper reservoir. Cooling is provided by a boiling/siphon loop on one side of the heat exchanger, that recycles to separator #2. Boil-off from this separator is returned to the local compressor via the recovery heat exchanger. The boiling point in separator #2 is set by the local recovery compressor suction pressure, which has to operate low enough to keep the condensing pressure in the cavity's helium space below the maximum allowable working pressure.

Cavity Cryostat and Condenser space/Liquid Reservoir

The cavity is enclosed in a Titanium vessel that carries the liquid helium bath that cools the cavity. It is connected to a holdup vessel that will contain a condenser/boiler heat exchanger

Beam tube ends thermal transition heat intercept

Both beam tube transitions to the warm bore will have a heat intercept using 1.5 atm, 4.6K helium from separator #1. A flow of 0.05 g/s is budgeted, for a heat intercept of 20W from 4.6K to ~ 80K. The exit helium will be used to cool the thermal shield. This flow is returned to RHIC main warm return header located in the tunnel.

Fundamental damper thermal transition heat intercept

The fundamental damper walls will have a heat intercept using 1.5 atm, 4.6K helium from separator #1. A flow of 0.075 g/s is budgeted, for a heat intercept of 30W from 4.6K to ~ 80K. The exit helium flow is returned to RHIC main warm return header located in the tunnel.

Thermal Shield

The thermal shield is cooled by the two exit gas streams of the beam-tube thermal transitions. The thermal shield helium gas is returned to RHIC's main warm return header located in the tunnel. An outer MLI system will be mounted on the vacuum vessel wall to reduce the heat load on the thermal shield.

Liquid Fill Line for portable dewar fill

A bayonet connection is provided into separator #2 to allow cold tests while the RHIC cryoplant is shutdown.

1.2 System Heat Loads

Item	Load @ 4.45K	Flow	RHIC Main Cryo Plant Refrigeration Load	RHIC Main Cryo Plant Liquefaction Load	RHIC Main Cryo Compressor Power (@20% Carnot)
	W	g/s	W	g/s	MW
Separator 1	40		40		0.015
Cavity Cryostat + Hold up Volume / Condenser Cryostat/Separator#2	100			5.7	0.199
Beam tube Thermal transition Intercepts plus flow to shield in series		2x 0.05		0.1	0.0036
Fundamental Damper Thermal Intercept		0.075		0.075	0.0028
TOTAL				5.875	0.22

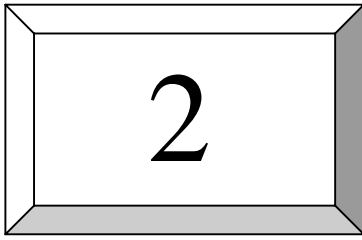

CRYOSTAT

2.1 Cavity Cooling

The preferred method is to cool the cavity in a helium bath (nucleate pool boiling). Because of the tight pressure variation requirements on the helium bath, and the vibration pulses from RHIC's main cryogenic lines, a condenser/boiler system is proposed to recondense the vapor generated within the cavity's cryostat system vapor space.

Heat Flux Density

The total heat dissipation due to losses on the Niobium surface is estimated at 42W. With peak dissipation densities at the damper end of the cavity. Maximum heat flux density is 40 W/m². This means that for most of the surface cavity surface the heat flux will be in the free convection regime or the surface will superheat approximately 50 mK above the saturation temperature before nucleate boiling will occur. It is

Vapor trapping on inner annular volume

Because of the geometry of the cavity, the inner annular space of the cavity will trap vapor that is generated from the boiling process on the high point on the inner annulus of the niobium surface. This is believe not pose a problem, but a simple experiment in a small dewar has been setup to determine whether the trapped vapor will lead to any excessive temperatures at the high point of the curved niobium surface.

Conduction cooling of Cavity

Some parts of the cavity, such as the tuning surface will conduction cooled. The heat dissipation flux is low enough to allow conduction cooling to the edge of the tuner plate, and still keep the tuner surface temperature below

2.2 Liquid Helium Supply Pressure Pulses and Mechanical Vibrations

Helium supply from RHICs

Due to the tuning requirements of the cavity, every effort is made to eliminate, minimize, dampen, or isolate sources of mechanical vibration or variation in pressure in the cavity's helium reservoir, piping, and support system. A condenser/boiler system is proposed to recondense the vapor generated by the cavity heat load, to isolate the cavity helium space from the helium supply/return of the cryogenic system and plant.

Piping 1st Modes

Piping connected to the cavity reservoirs will be engineered to have sufficient stiffness to obtain 1st modes with frequencies greater than 100 Hz.

TAO

To mitigate any Thermal Acoustic Oscillations, TAO, no small diameter tubing shall be used that will extend to warm region outside the vacuum boundary. Small diameter relief lines shall have a check valve at the cold end of the line, and any instrumentation tubing for pressure sensors shall have a 5 turn cold end stabilization loop in the tubing. Stability analysis shall be done on other tubing connected to a warm environment.

Pool boiling Noise

In general, noise from boiling helium has a broad frequency spectrum and sufficiently low enough amplitude to not be an issue.

2.3 Heat Load Breakdown

HELIUM LOAD 1: Returns back to RHIC Vapor Return Header: $20 + 9.3 = 29.3$. Budget: 40 W

This load includes the transfer lines loads and the 1st phase separator that isolates the Collider supply transients from the cavity system. The boil from this phase separator is returned to the Collider's main cold vapor return line.

Cold transfer line system from/to RHIC main cryogenic lines: 15 W

Phase separator #1 Loop: 9.3W

Supports: 2 W	Helium Vessel, unshielded: 2 W
2 Valves: 3W	Helium Lines: 1 W
Instrument lines: 0.3W	Relief line: 1W

HELIUM LOAD 2: Returns back to Cavity Cryostat's Refrigeration Recovery Compressor:

$Q = 74.8$ W. Budget: **100W**

(~ 5 g/s liquefaction load on RHIC Plant without recovery)

Separator #2 and Condenser / Hold-up Vessel (Separator#3): 18.3W

Helium Holdup vessel Radiant Load, shielded: 2 W	
Supports: 2 W	Helium Lines: 1 W
4 Valves: 8W	Instrument lines: 0.3W
Relief line: 5W	

Cavity Cryostat: 14.5 + 42 = 56.5 W

Helium vessel Radiant Load, shielded: 2W

Beam tube end with intercept (Damper end): 3 W

Besides the conductive load, the thermal radiation the load is minimized by having a low emissivity surface thermal transition material. In order to reflect the warm bore radiation properly, the surface has to behave as a diffuse reflecting surface, not a specular reflecting surface.

Beam tube end with intercept (Tuner end): 3 W

Supports: 2 W

Tuner: 2W

Fundamental Damper: 2W

Power coupler: 0.5 W

Maximum Dynamic: 42 W

HEAT STATION LOADS

Fundamental Damper Heat intercept station flow: 0.075 g/s

Beam Tube End (tuner side): heat intercept station and cryostat radiation shield: 0.05 g/s.

2.4 Equipment

SEPARATOR #1

Vessel size, vapor space, and separation requirements are set by larger of:

- a. Separation requirement due to Heat load on the separator loop which includes transfer line heat leak
 - b. Hold up time requirements
 - c. Vapor space required to dampen liquid/vapor fluctuations from the supply
-
- a. Maximum saturation condition to 1.65 atm. 4.8K
Liquid density: 110.1 kg/m³. Vapor Density: 30.4 kg/m³
Vapor mass flow steady state nominal: 2 g/s
Vapor mass flow peak: 6 g/s
Minimum required diameter for separation: 12 inch
 - b. Holdup requirements
Hold up time: 20 min
Hold up Liquid requirement: 12000 grams
Hold up liquid volume required: 100 liters
 - c. Vapor space required to dampen liquid/vapor fluctuations from the supply
For 1 psi (69 mbar) low frequency (10Hz and lower) variation in liquid supply pressure (3.5 atm supply), there will be a corresponding variation the flowrate into the separator, through the supply control valve. For a maximum 10 g/s supply and a flow variation of 2%, for pulses under 10 Hz, 100 liters vapor space would provide a pressure change of order 1 mbar in separator #1.

Design size: 22 in Dia. x 36 in H.

SEPARATOR #2

Separator #2, which handles the heat load from the cavity/holdup volume reservoir via the condenser/boiler heat exchanger. It receives the boil-off and supplies the liquid to the boiler/condenser heat exchanger located in the cryostat holdup volume. Liquid is supplied to this separator from Separator #1. Separator minimum diameter is set by total heat load duty.

- a. Maximum saturation condition to 1.3 atm. 4.5K
Liquid density: 118.1 kg/m³. Vapor Density: 22.4 kg/m³
Vapor mass flow steady state nominal: 6 g/s
Vapor mass flow peak: 6 g/s
Minimum required diameter for separation: 12 inch
- b. Holdup requirements
Hold up time: 20 min
Hold up Liquid requirement: 7200 grams
Hold up liquid volume required: 60 liters

Design size: 22 in Dia. x 36 in H.

SEPARATOR #3 Cavity Hold-up vessel

Response of pressure transients caused from thermal transients by the cavity's change in dynamic dissipation load will be dictated by the size of the vapor space, the condenser response. Using 1000 liter vessel with 500 liter vapor space, the vapor phase inventory is about 10 kg.

Fast Transients: With a 0.1 mbar variation will handle a dynamic variation in the load of ~20 Joules.

Slow transients: For load changes over long time span, the condensing/boiler and vapor inventory system will react to this with a shift in operating state point.

For a load increase of 40W, heat transfer gradient will increase approximately 50 mK, with a vapor pressure slope $dT/dP \sim 1 \text{ mK/mbar}$, the increase in vapor pressure on the cavity will cause of shift of $50 \text{ mbar} \times \sim 0.3 \text{ Hz/mbar} \sim 15 \text{ Hz}$.

Liquid level head effects

With liquid densities of around 120 g/L, a 1 cm change in liquid will change the pressure above the cavity by 0.12 mbar

Design size: 36 in Dia. x 60 in H

Condenser/Boiler Heat Exchanger

Condenser side

Condensing heat transfer film coefficients remain constant at around $600 \text{ W/m}^2\text{-K}$.

For a condensing temperature gradient of 25 mK and 100 W load, a condensing surface area of 6.6 m^2 is required.

Boiler Side

A siphon loop will be setup between the boiler side of the heat exchanger and the separator vessel. If a finned copper tube design is used, with a nominal tube area to fin area ratio of 1:6, a nucleate boiling temperature gradient of approximately 55 mK will be established. The boiling side heat transfer gradient can be improved if the surface roughness on the tube side can be increased to increase nucleation and therefore the heat transfer coefficient.

A brazed aluminum plate-fin heat exchanger option will be investigated also, since these have been in used as sub-cooler heat exchangers in liquid helium reservoir.

Duty: 85 W
UA: 773 W/K
Surface Area Condensing Side: 6.6 m^2
Surface Area Boiler Side: 1.1 m^2

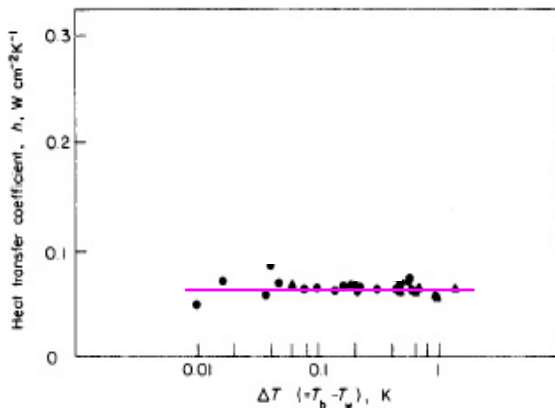

Condensing Heat Transfer Coefficient

2.5 Cooldown

A cooldown line is provided to supply helium from the first separator to a lower port on the cavity for cooldown. Analysis to study cooldown temperature gradients and stresses still needs to be carried out. Cooldown from room temperature to 150K can be carried out at a slower pace, and accelerated below 150K to transition through the Q-disease regime quickly.

2.6 Warmup

To provide reasonable warm-up time, heaters can be installed on the Titanium helium vessel. A purge line into separator #2 is provided for purging and warm-up. Gas can enter the cavity via the cooldown valve and warm the cavity.

2.7 Reliefs

	Separator #1	Separator #2 / Condenser- Boiler	Cavity helium volume & Condensing space / Hold-up tank (Separator #3)	UHV BEAM TUBE Reliefs
MAWP Pressure	275 psia	100 psig	20 psia	
Normal Operating	25 psia	16.2 psia	17.7 psia	
Relief -1 SP	250 psig	100 psig	5 psig (20 psia)	6 psig
Relief-2 SP			8 psig (23 psia)	
Criteria -1	Loss of insulating vacuum to air	Loss of insulating vacuum to air	Cooldown flow	Cavity breach, helium into UHV
Flow-1	TBD	TBD	25 g/s	TBD
Criteria -2			Loss of UHV beam vacuum to air	
Flow-2			2500 g/s	

2.8 Process Data, Nominal Steady State

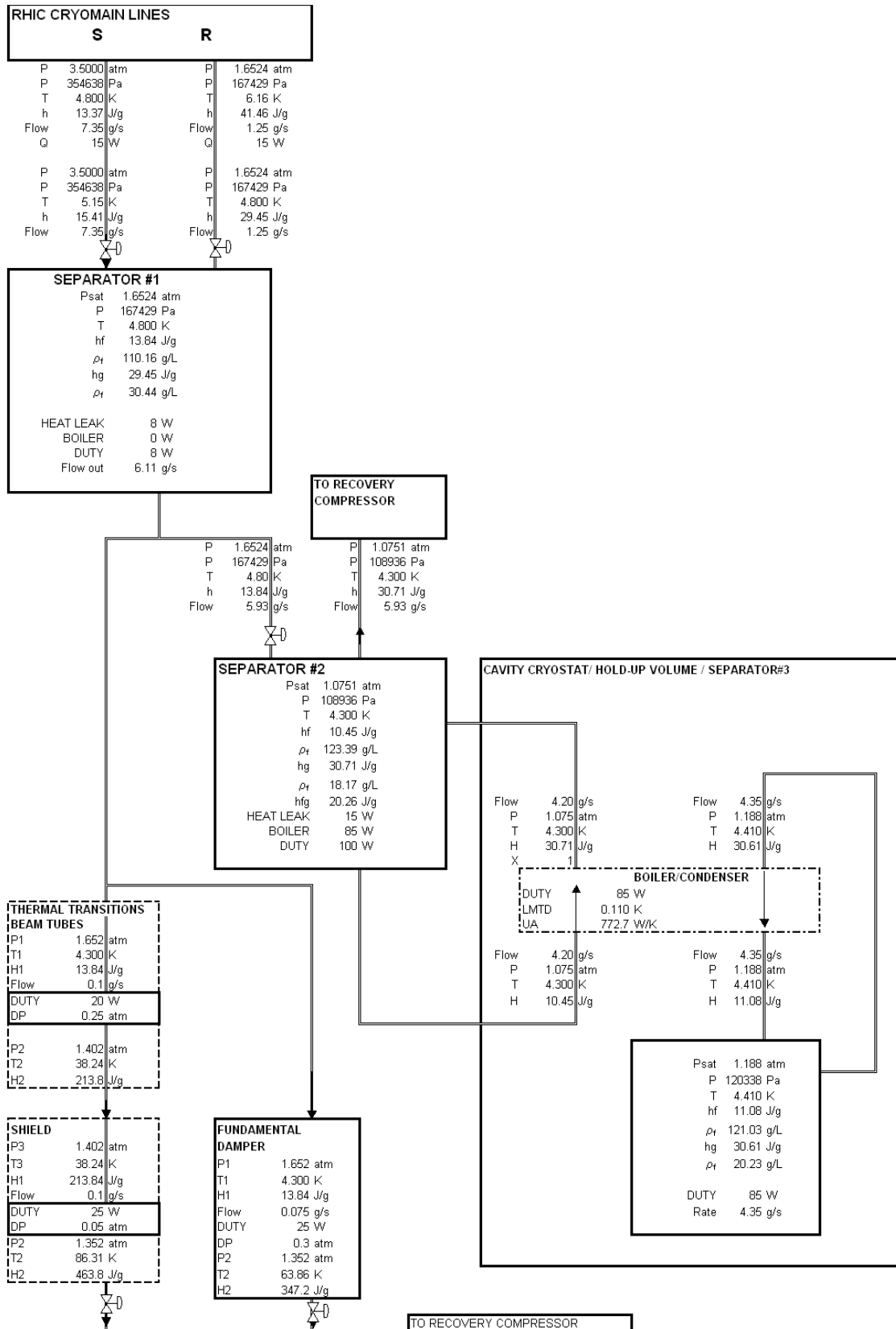

COLLIDER ACCELERATOR DEPARTMENT

Project: 56 MHz SCRF Cavity

Title: Cryogenic and Cryostat System for the 56 MHz Cavity

Rev: Design Review Jan 09

10

References

Sato, S, and Ogata, H. "Film condensation heat transfer of helium in a vertical tube". Cryogenics, April 1976.

Van Sciver, S. W., " Helium Cryogenics", Plenum Press, New York, 1986.