



BNL-104537-2014-TECH

AGS/AD/Tech Note No. 105;BNL-104537-2014-IR

DESCRIPTION OF THE SLOW EXTRACTED BEAM SECURITY SYSTEM CIRCUITS

A. McGeary

June 1973

Collider Accelerator Department
Brookhaven National Laboratory

U.S. Department of Energy

USDOE Office of Science (SC)

Notice: This technical note has been authored by employees of Brookhaven Science Associates, LLC under Contract No.AT(30-1)-16 with the U.S. Department of Energy. The publisher by accepting the technical note for publication acknowledges that the United States Government retains a non-exclusive, paid-up, irrevocable, world-wide license to publish or reproduce the published form of this technical note, or allow others to do so, for United States Government purposes.

DISCLAIMER

This report was prepared as an account of work sponsored by an agency of the United States Government. Neither the United States Government nor any agency thereof, nor any of their employees, nor any of their contractors, subcontractors, or their employees, makes any warranty, express or implied, or assumes any legal liability or responsibility for the accuracy, completeness, or any third party's use or the results of such use of any information, apparatus, product, or process disclosed, or represents that its use would not infringe privately owned rights. Reference herein to any specific commercial product, process, or service by trade name, trademark, manufacturer, or otherwise, does not necessarily constitute or imply its endorsement, recommendation, or favoring by the United States Government or any agency thereof or its contractors or subcontractors. The views and opinions of authors expressed herein do not necessarily state or reflect those of the United States Government or any agency thereof.

Accelerator Department
BROOKHAVEN NATIONAL LABORATORY
Associated Universities, Inc.
Upton, New York

AGS DIVISION TECHNICAL NOTE

No. 105

A. McGeary
June 15, 1973

DESCRIPTION OF THE SLOW EXTRACTED BEAM
SECURITY SYSTEM CIRCUITS

This paper describes the design concepts and hardware configuration of the slow extracted beam (SEB) security system. SEB security is really a subsystem of the AGS ring security system in that it is intimately tied into AGS by both monitoring status of and interlocking certain functions of the AGS system. The description is organized into three topics:

- 1) Caves and gate circuits.
- 2) Clearance circuits.
- 3) Equipment monitoring and interlocking circuits.

Many of the security system concepts in SEB have been taken from the AGS ring system (gates, clearances, restricted/controlled access modes, sweeping of caves) therefore a familiarity with the AGS Ring Analysis - W. Gefers, is fundamental to this discussion. In addition SEB security involves some features not encountered in AGS ring security such as the beam switchyard providing several options for beam delivery, the existence of primary and secondary beam areas requiring two levels of security, and the Health Physics Group (HP) controls on gates. Simplified schematics are included to show the control logic but not the actual wiring of the circuitry.

Caves and Gate Circuits

Presently there exist 5 primary beam caves containing beam lines to two primary target stations B and C/C'. The options for beam delivery are then C station or B and C station split. In addition to the primary beam lines, there are secondary beam lines downstream of the target stations which transport secondary beams to the experimental apparatus. These areas will not be discussed except to mention that a less rigorous treatment is given to them and a failure or abnormal condition, e.g. beam plug open and gate open, will interlock primary SEB.

To extract beam from the AGS the appropriate beam caves must first be secured. The details of which caves for which beams will be given in the discussion of clearances. All primary gates are of the same design, a 36" X 96" aluminum door on which is mounted an electro-mechanical deadbolt operating into a door jamb mounted assembly which senses door position and deadbolt position. Door position is sensed by means of a magnetically actuated switch, JS2. Deadbolt position (through the door jamb and into the jamb assembly) is sensed by a spring finger switch, JS1 which the deadbolt closes. Figure 1 illustrates all of the interlocking circuits for a typical gate, but omits for simplicity all indicator lights of which there are 18.

For emergency access either way, a manually operated slide bar on the inside and a "break glass-turn handle" assembly on the outside always provides exit or entry to the cave regardless of the presence of electrical power. This is required for fire safety. The microswitch BS1 in the bolt assembly drop out the gate reset relay K6 even before JS1 and JS2 open.

SEB restricted/controlled access states are quite similar to those in the AGS ring. Controlled access (K1 energized) implies an intent to activate the corresponding area and is the first step required in securing for beam.

A gate reset condition (K6 energize) is a ready for beam state indicating that corresponding beam areas have indeed been swept clear of personnel. The gate reset relay contact closure K6 is the one interlock from that gate to the rest of the SEB security logic for the acquisition of permission or "clearance" to extract beam. Additional redundant circuits for each gate consisting of a separate door switch and relay will be added at a future time to bring SEB gate redundancy up to the level of the AGS ring gates.

All SEB primary gates have a provision for interfacing with a health physics group (HP) radiation monitor. Basically the radiation monitor provides a high/low radiation indication to the gate controls by energizing K2. For a high radiation condition, K2 de-energized, the gate is interlocked by the HP BNL 9 key in addition to the AGS operators BNL 11 key which is always required for entry when on controlled access. See Fig. 1. In the event no HP monitor is connected to the gate (open circuit) the gate indicates the high level radiation condition. This philosophy extends to all circuit designs in all security systems, i.e. circuit continuity or relay contact closure is always required to indicate a safe condition. This assumes that the typical mode of failure of a circuit is an open rather than a short. Similarly, the clearing of an interlock is always accomplished by application of a control voltage (energizing of a relay). Therefore, loss of control voltage, for example, because of an open circuit, causes a device to be interlocked off, which for most cases the safe condition, e.g. an extraction magnet P.S. For each device connected to a security system, the determination of the safe and unsafe state of the device is evaluated in the initial design of that system.

Pushbuttons S1, S2 are provided on both control stations to provide entry and exit respectively through the gate during periods of restricted access (K1 de-energized).

An additional pushbutton S3 gives the operator the option of 1) locking a gate behind him to keep control of personnel entering the cave while not resetting the gate (K6 remains dropped out) or 2) locking and resetting the gate (energizing K6) during initial sweep of the cave when exit is to be made at a second gate. Most beam caves have two gates providing an option for egress in the event of fire.

The requirement for simultaneous operation of main control room switch S4 when opening any gate from the outside gives the main control room operator complete control over gate entry during controlled access periods. In addition, K3 or K4 must also be energized before the gate is opened insuring that the AGS circulating beam or the SEB is indeed off.

Sweeping of the SEB caves is accomplished by a team of two operators; sometimes a third HP technician. Generally beginning at the most outlying gate they lock and reset one gate from the inside using the BNL 11 key, search the length of the cave for personnel and perform a general visual inspection of the area, exit through the second gate locking and resetting that gate from the outside again with the BNL 11 key. Upon resetting (K6) the last gate in each cave the normal lighting in that cave is turned off providing a warning to anyone who may have been left in the cave that the cave is secured. Only the BNL 11 key under control of the control room operator will reset (energize K6) at each gate. This same key normally resides in a captive keyswitch in the main control room. No clearances for SEB may be obtained unless this key is indeed in its captive keyswitch. Also, removal of this key from its captive keyswitch will normally interlock SEB except for one special procedure in which up to a 30 minute bypass interval may be initiated by the operator to enable SEB to remain on while the key is in transit prior to opening a gate. The BNL 11 captive keyswitch logic is shown in Fig. 2.

Of course, each time a gate is opened K6 drops out interlocking the appropriate SEB clearance and must be reset upon clearing the gate by the operator using the BNL 11 key. The operator uses the AGS SECURITY SIGN IN/OUT sheets Form 1669B, providing a record of all personnel entering the cave.

Clearance Circuits

In order to provide an orderly controlled process of turning on the SEB, clearance circuits are used. Figure 2 shows in simplified form all of the series interlocks which must be satisfied before A, B, or C SEB clearance may be requested. With the obtainment, of the clearance the corresponding clearance relay, K20 for SEB C and K22 for SEB B, energizes and remains energized for the duration of the clearance. Contacts of K20 and K22 are used to interlock the various devices which are capable of generating an extracted beam. Therefore, once clearance is obtained, extracted beam is feasible.

The clearance is granted by HP who have developed their own procedures and checks associated with each mode of extracted beam. Once the HP technician is satisfied that conditions are safe for extracted beam he calls in the clearance to the experimental area operations control room (EAO target desk) where the EAO operator turns the keyswitch S2 for C or S3 for B. Again, similar to the AGS ring the clearance must be used within 30 minutes or it expires by time-out of the motor driven time delay relays K18 and K21 except for one case to be discussed later. For example, for SEB C, K20 picks up and seals itself in upon operation of the keyswitch S2. Contacts of K20 immediately start the 30 minute time-out of K18. The time-out is reset only after all conditions required for definition of SEB C ON (K32) have been met. The F5 and F10 septum magnets must be off their retract limit position, i.e. in the beam (K25, K26) the F5 and F10 magnet power supplies must be on (K27, K28) the four SEB sextupole magnets must be on to excite the $\nu=8^{2/3}$ resonance on which the extraction occurs (K29); the SEB powered backleg windings must be on to bump beam into the extraction magnets (K30) and the AGS accelerated beam must be on (K31). In addition, there is a requirement that

there be low current in the CD1 and CD2 dipole magnets which were used to switch SEB from the C to the A target (K23, K24). This circuit is no longer applicable since the SEB A line has been dismantled.

The one case where clearance does not time-out is the condition where the K18 timer is bypassed by contacts of K19. This is the "accelerator research" or non-high energy physics mode described in the AGS ring security paper.

Even prior to requesting a clearance all the other series contacts must be closed. K7 is a closure indicating that the BNL 11 key which opens all gates is captive in the control room keyswitch. K8 is the "key transfer mode" described earlier in which the key may be pulled and carried to a gate while maintaining clearance. K9 insures that no clearance can be obtained without accelerated beam clearance first. S1 provides a means for cancelling clearance from the main control room. 1K6-7K6 are the reset relays for the 7 gates in the first four primary beam caves which must be secured for C SEB. The layout of these caves is best seen on drawings D14 692 and D14 696.

Secondary gate 5 (S5K6) is a special case of a secondary gate interlocking a primary gate under certain conditions. Securing of secondary gate 5 is not required if the experimenters magnet C1D1 is turned off (K10 energized) or if entry through the gate is made by the HP group using a BNL 9. K11 picks up when the BNL 9 is used to open the gate and drop out when the gate is reset by HP.

If primary gates 8 and 9 are not reset then K12, K13 and K14 must be picked up. These are respectively, closure of the B396 beam plug, off condition of the "RTB" magnet power supply and off condition of the BD3-6 magnet power supply.

CD1,2 dipole magnets additionally must be set for low current to insure that beam will go into the C line rather than the A line (K15 dropped out).

The sensing of current levels in magnets is typically accomplished by means of Westinghouse "D3 type" overcurrent relays installed in the Acme power supply driving the magnet. These overcurrent relays are specifically installed for security purposes whereas each Acme supply has its own "D3 type" relay for power supply protection.

The last requirement for C clearance is the correct position of the C85 beam plug. The beam plug is initially closed since it is interlocked against opening until the C clearance, K20, energizes. This means K16 is picked up. Therefore the clearance is obtained through K17 which also is picked up for SEB off. Consequently C85 must be opened before SEB is turned on as defined by F5 and F10 magnet position, F5, F10, sextupole and power backleg winding supplies and accelerated beam. If this sequence is not followed the SEB C clearance will be lost.

The only additional interlock on the B clearance are reset relays of primary gates 8 and 9 (8K6, 9K6) which secure the B target station cave. Not shown in Fig. 2 or the typical gate schematic, Fig. 1 is the existence of two new primary gate interlocks. These are presently known as the B1 and B5 primary beam caves. Each has a gate which temporarily for the recent B station run was padlocked and reset locally by the BNL 11 key. Door switches were installed so that if the gates were opened their reset relays would drop out and in turn drop out the gate 9 reset relay 9K6. Simply, put, the B1 and B5 gates interlock gate 9 which interlocks B clearance. This circuit was an expedient to provide more than "padlock gate" security in the face of a unavailability of hardware and manpower required to build standard primary gates.

The definition of B SEB ON is C SEB ON with the addition of RTB and BD3-6 dipoles on. These conditions drop out K33 which stops the time-out of the K21 timer and thereby holds B clearance.

Equipment Monitoring and Interlocking Circuits

The SEB security system functions by monitoring the status of and interlocking the various pieces of equipment in the accelerator which are capable either individually or in conjunction with other devices of creating a radiation hazard. Both status monitoring and interlocking are accomplished through use of "hard wired" control circuits using control cable, control relays and heavy duty switches and pushbuttons. For example, the F10 septum magnet power supply, one of several devices required for SEB extraction, contains as one of several interlocks against DC ON a relay contact from SEB security which must be closed to allow the DC ON condition. To monitor the status of the power supply an auxiliary contact on the 440 V ac contactor is used solely to provide the OFF condition to the security circuits. Again a circuit closure or energizing of a relay provides the OFF or safe indication to the security system. This is the reason for most all of security relays being identified typically P.S. OFF, BEAM OFF, MAGNET RETRACTED, BEAM PLUG IN.

A listing of the various equipments associated with SEB security follows:

1. AGS rf system.
2. AGS HEBT beam stoppers (1 & 2).
3. AGS magnet pulsing power supply.
4. A20 inflector power supply.
5. F5 magnet.
6. F5 flag.
7. F5 power supply.
8. F10 magnet.
9. F10 flag.
10. F10 power supply.
11. SEB sextupole power supply.

12. F10 powered backleg winding P.S.
13. CD1/2 magnet power supply.
14. RTB magnet power supply.
15. BD3-6 magnet P.S.
16. B1D1,2 magnet P.S.
17. C1D1 magnet P.S.
18. C85 radiation plug.
19. C334 radiation plug.
20. C392 radiation plug.
21. B396 radiation plug.

In the original SEB security design the primary means of interlocking the SEB upon the loss of SEB clearance was to interlock the F5, F10 sextupole and powered backleg winding power supplies directly. However, during operation it became apparent that this method was not desirable for two reasons: 1) sudden loss of SEB clearance would result in the loss of full energy protons around the circumference of the AGS particularly in straight sections where magnets were located causing unnecessary radiation to these components, and 2) there were often difficulties bringing the various equipments on again and setting up for proper extraction. Therefore the interlocking circuits were redesigned to shut off the AGS circulating beam upon loss of SEB clearance while allowing the SEB power supplies to remain on. This was accomplished simply by closing the AGS beam stoppers now located in the HEBT line between linac and AGS. In the event the beam stoppers fail to close the SEB equipment is then interlocked directly. A 2 second time interval is allowed for beam stopper closure. If they do not indicate full closed at the end of this interval the SEB equipment is shut down. Figure 3 shows the logic of the interlocks on the SEB equipment. There is a second means by which the SEB equipment may be kept on without clearance. This is the "HEBT zero degree" mode where 200 MeV

beam is allowed to run from linac beyond the AGS beam stoppers into the AGS ring enclosure. In order to insure beam cannot spiral around the AGS two independent means are used to prevent this and define "HEBT zero degree" operation. These are: 1) the main magnet pulsing must be off (K36) the inflector P.S. must be off, K37.

There is another where some SEB power supplies may be brought on without B or C clearance. This is through use of the "F10 secondary beam" clearance. This is a mode of operation where although full primary beam cannot be brought out of the AGS, a secondary particle beam from the vicinity of the F10 septum magnet can be expected. The requirements for this mode are security of the first primary beam cave (gates 1 and 2) and closure of the first beam plug in the C line, C85. This allows for checkout of SEB power supplies on an individual basis, i.e. no more than one on at a time prior to actual SEB operation. It should be noted that security interlocks on various equipments can severely hamper the testing and maintenance of these equipments if there are not provided other options for their operation other than full beam clearance. The most often used alternate means for operation extraction equipment is the AGS beam stoppers closed bypass, K35.

Figure 3 shows in simplified form the logic of the SEB interlock on the AGS beam stopper. A newly added K46 contact is quite unique. When B beam is on, K46 opens on a 100° C temperature rise of a uranium beam dump located just downstream of target B' in the B5 beam.

K20 and K22 contacts are clear, assuming K46 closed a B or C clearance clears K47. If a B or C clearance is inappropriate an F10 secondary clearance (K39) allows opening of beam stoppers providing no more than one power supply is energized. K45 simply provides some redundancy of the SEB equipment monitoring.

If there are no clearances than the K42-K45 string insures that all SEB

supplies stay off unless their corresponding magnets are retracted. This also includes the CD1/2 power supply which was used for the old A line extraction. K44 and K45 provide further redundancy on the equipment monitoring. There is additional redundancy in this circuit not shown here for the sake of clarity. The SEB interlock scheme thereby provides for direct interlocking of SEB through the normal equipment security interlock, e.g. K40, but in addition if by some malfunction one of these equipments is operated "illegally" the AGS circulating beam is shut down, (K47).

Distr.: Dept. Admin.
AGS Division Staff
MCR Operators

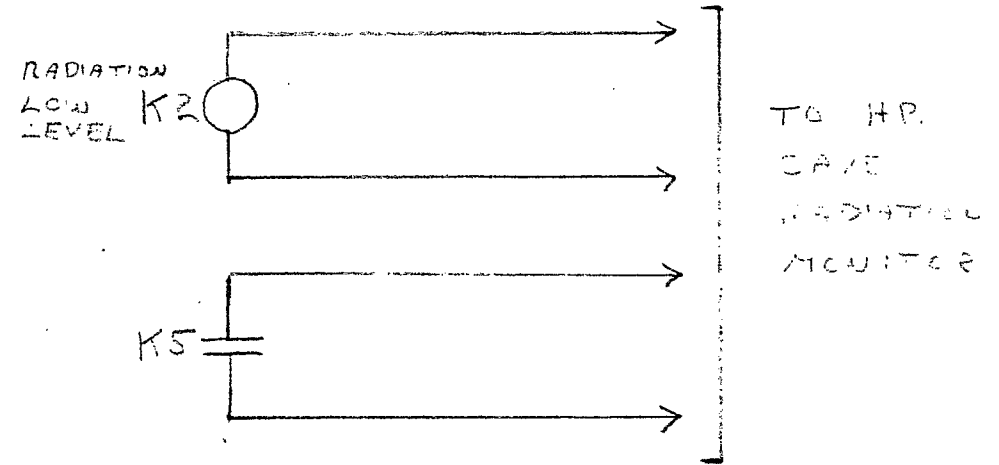
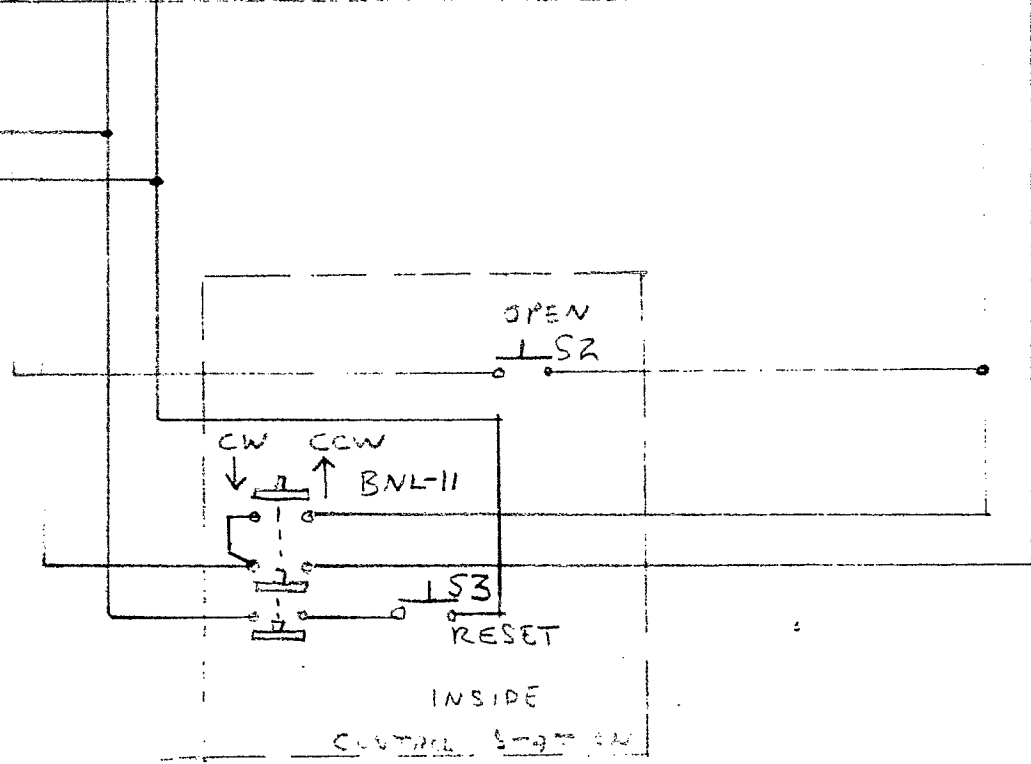
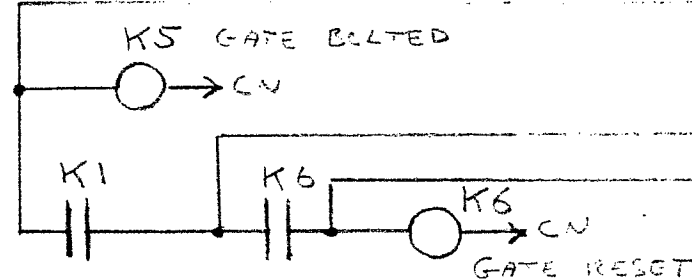
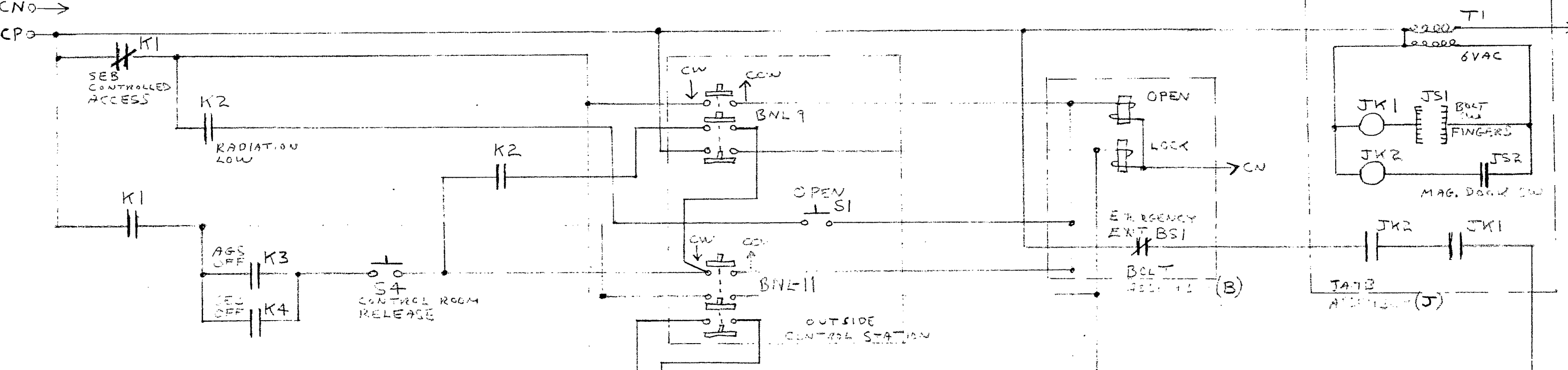

NOTES

1. ALL LIGHTS WHICH ONLY PROVIDE INFORMATION ON GATE STATUS ARE NOT SHOWN.
2. KEYSWITCHES (BNL-9, BNL-11) HAVE BOTH CLOCKWISE AND COUNTERCLOCKWISE POSITIONS IN ADDITION TO THE NORMAL (CENTER-KEY PULLED) POSITION. CW OPENS BOLT, CCW LOCKS BOLT.
3. K1-6 ARE GE CR120 TYPE
4. JK1, 2 ARE CONTACT GATE PLUGS

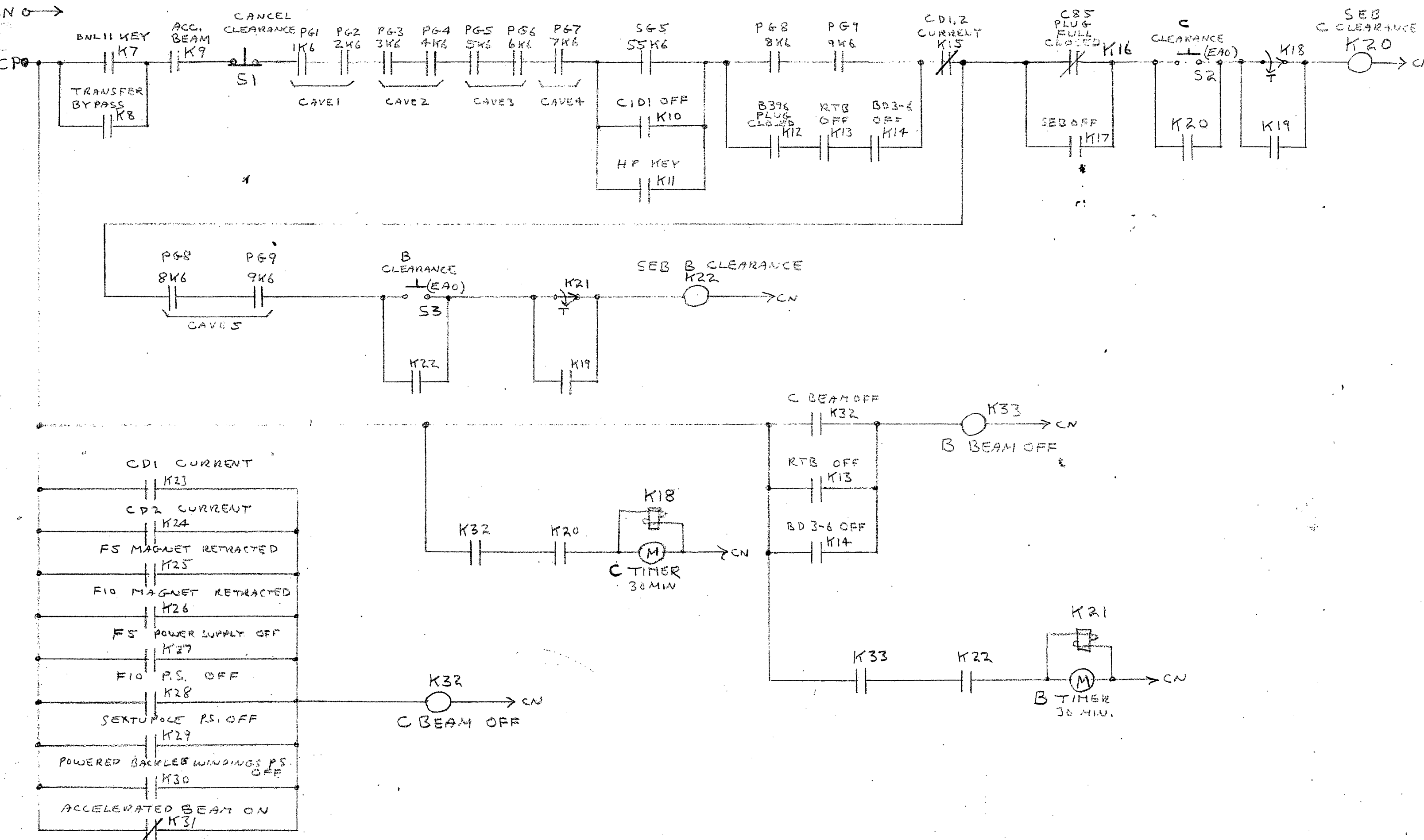

FIG. 3

