

MG SET VOLTAGE RECORDER

R. Cassel

July 1965

Collider Accelerator Department
Brookhaven National Laboratory

U.S. Department of Energy

USDOE Office of Science (SC)

Notice: This technical note has been authored by employees of Brookhaven Science Associates, LLC under Contract No.AT-30-2-GEN-16 with the U.S. Department of Energy. The publisher by accepting the technical note for publication acknowledges that the United States Government retains a non-exclusive, paid-up, irrevocable, world-wide license to publish or reproduce the published form of this technical note, or allow others to do so, for United States Government purposes.

DISCLAIMER

This report was prepared as an account of work sponsored by an agency of the United States Government. Neither the United States Government nor any agency thereof, nor any of their employees, nor any of their contractors, subcontractors, or their employees, makes any warranty, express or implied, or assumes any legal liability or responsibility for the accuracy, completeness, or any third party's use or the results of such use of any information, apparatus, product, or process disclosed, or represents that its use would not infringe privately owned rights. Reference herein to any specific commercial product, process, or service by trade name, trademark, manufacturer, or otherwise, does not necessarily constitute or imply its endorsement, recommendation, or favoring by the United States Government or any agency thereof or its contractors or subcontractors. The views and opinions of authors expressed herein do not necessarily state or reflect those of the United States Government or any agency thereof.

Accelerator Department
BROOKHAVEN NATIONAL LABORATORY
Associated Universities, Inc.
Upton, L.I., N.Y.

AGS DIVISION TECHNICAL NOTE

No. 2

R. Cassel
July 23, 1965

MG SET VOLTAGE RECORDER

The most serious instrumentation problem of the Power Room is the lack of a means to record individual pulses and store them for future observation. This manifests itself by having no record of faults which occur or changes in the operation of the MG set so as to enable detection of the trouble. At present, chart recorders are used, but their frequency response is so low that very little can be learned from them. The Cosmotron uses a storage scope to record faults. However, the lifetime of storage tubes is very short and the tubes are expensive.

I would, therefore, like to construct a special type tape recorder which operates as follows:

Frequency response dc ~ 4 kc FM modulated

Tape speed approximately 1 to 2 IPS

Four track system

Fixed write head

Rotating read head

Standard magnetic recording tape with 10½-in. reels which will give approximately 10 to 20 hours per reel.

Operation

Write head would record as a standard FM tape recorder, recording the ring voltage wave form, current wave form and any other single track of information. The fourth track would be used for coding digits to determine the correct pulse.

Readout would be made by selecting the code digit desired. The rotating read head would then scan for the correct code word; upon finding the correct pulse it would stop the tape and repeat the same pulse over and over again. See figure for block diagram.

This same type of recorder could be used for the spill to determine long time changes in the spill, etc.

Distribution: E.B. Forsyth
A. Maschke
A. van Steenberg

BROOKHAVEN NATIONAL LABORATORY

BY _____ DATE _____ SUBJECT _____ SHEET No. _____ OF _____
CHKD. BY _____ DATE _____ DEPT. OR PROJECT _____ JOB No. _____

Block Diagram

Recorder For MB Set

R. Caswell

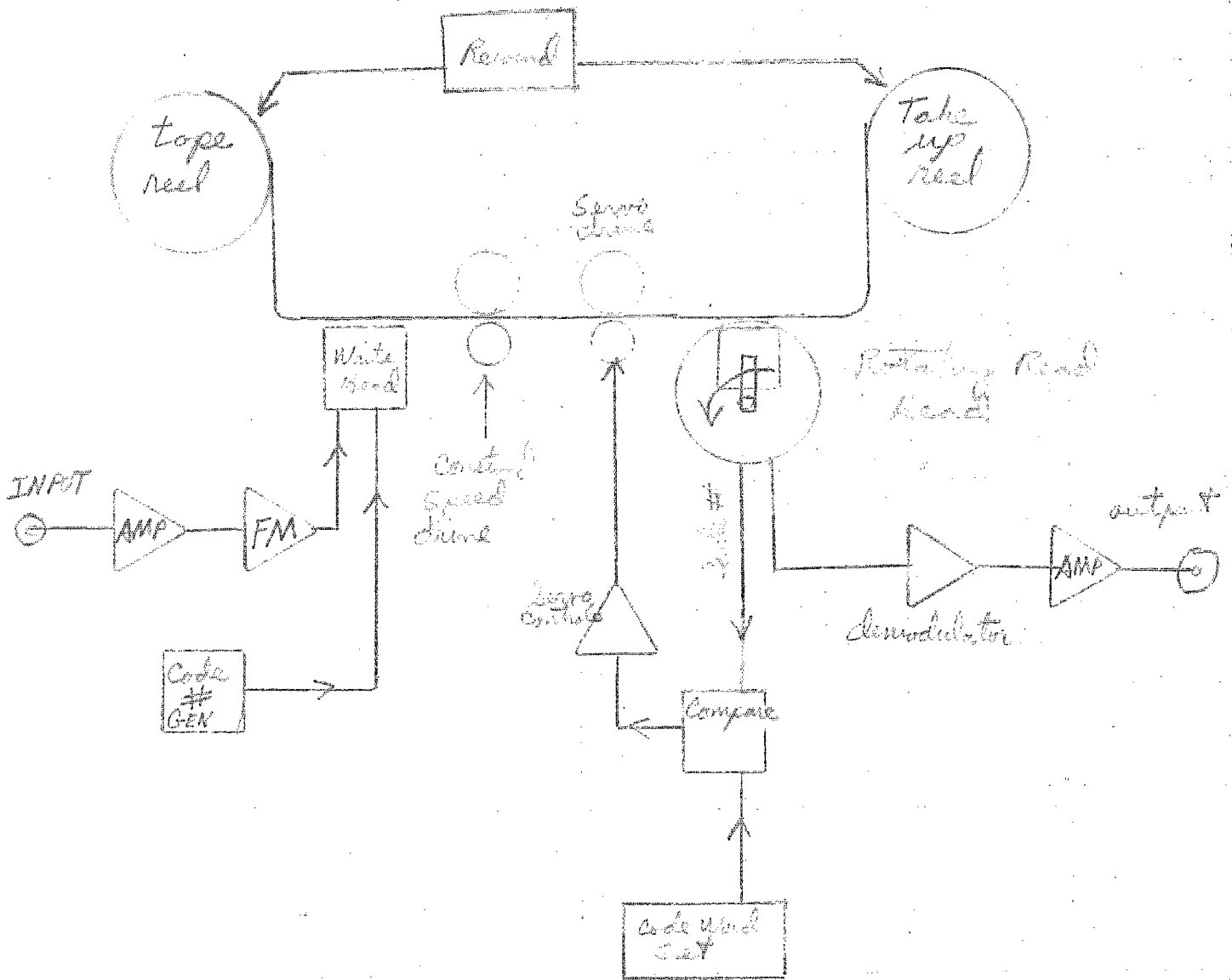

Status Report Preinjector (1)

Ion Sources

Experimental Ion Source

Measurements on the pre-column finished; a solenoid and (or) immersion lens with or without grid (see fig. 1) showed emittances composed of a divergent and convergent part. The final geometry is more or less a prolongation of the column viz., a Pierce geometry for a 500 mA beam intensity (see fig. 1c). With this geometry we measured a cleaner beam of simple convergent structure with a very weak divergent part. The telescopic structure of the cup provides the possibility of stronger focussing, if necessary. Some work continues on e.g. a grid in the cup and investigation of canal diameter in the intermediate electrode.

Operational Source

The R.C.A. cathode had a short life time of around 10 days. Cause seemed to be a too high running temperature ($\sim 1200^{\circ}\text{C}$) (see fig. 2). Home made cathode continues to run for already 21 days: 250 mA, 50 μs pulse, rep. rate 5 pulses per second. An emittance detector is nearly finished and work continues on a density distribution facility, mass analysis and air cooling of the cathode house plus solenoid will be investigated.

Second Operational Duoplasmatron

The final sketch is in the drafting room, which will be designed at the end of August.

In August a mercury pump will be installed in the original test facility. This facility will be available for the second operational duoplasmatron source.

PIG - Duoplasmatron Cartridge

Unit is nearly ready; the cooling (air or freon) is still not settled. Before this unit goes into the machine, it will be checked on the operational test facility.

Electronics

The requirements for the electronics of the duoplasmatron can be summarized as follows:

Cathode voltage: -300 V + display
Filament current: 30 A + display
Magnet current: 8 A + display
Discharge current: scope display (20 \rightarrow 40 A)
Pressure detection: thermo couple + display
(palladium leak)
Extractor: 70 kV + display
Freon cooling

This equipment will be available at the end of August.

Accelerating Column

General

A short column section (1/5 of the final length and without inner electrodes) has been tested at around 230 kV on its high voltage properties for 3 days with static freon in outer section. This is about 50% higher than we practically need. We hope to run again next week for another 11 days. After a successful test the skirts will be ordered and the testing continues for determination of upper limits.

Resistances

Due to a crack in one of the bananas some months ago, fillers in the epoxy has been tried out for better heat conduction to the electrode holders; up to now the experience with BN_3 filled resistances seems to be rather good. Some more tests will be made with 10, 50 and 100% BN_3 filler each in one resistor bloc; these blocs will be compared with an epoxy without filler; temperatures will be measured under proper H.V. tests. The best combination should be used for a final banana, which will be compared again with the original banana in a H.V. setup.

Short Column (see fig. 3)

Components and delivery schedule:

<u>Item</u>	<u>Delivery + final machining</u>
1. Ceramics	In
2. Ti electrodes	31 August
3. (electrode holders)	30 July
4. (column external)	20 August
5. (spinnings)	30 July
6. (column hardware + dome)	31 August
7. (Jigs + rigging)	15 August
8. (Resistors)	31 August
9. (Skirts)	31 December or later

Considering this list we can start building:

- a) Internal column without skirts from the 1st. of August on.
- b) External column without skirts and internal electrodes in the beginning of September. High voltage tests (up to about 600 kV) without or with source mounted can start at the end of September, if there is a H.V. building.

High Voltage Building

Components (see fig. 4)

- a) Hardware (columns, spinnings, phenolic tubes, bells pulleys etc.) are all in or sipping in before 31 of August.

- b) Capacitors arrived (need some more spares).
- c) R.D.I. power supply; not checked still.
- d) Source electronics: ready in August.
- e) Vacuum equipment; the final equipment (hardware) has just arrived from the drawing office; a guess-date for delivery is 1 December; we can however, install in our test facility vac-ion pump (Ti-pump); this will be available and can be installed during September.
- f) Connection Dome - H.V. stack.

Building

The present accommodation is inadequate for the 750 kV tests. A proposal of a new facility in the same building is made by Andy and Bill. This building has to be made "dust-free, humidity-controlled and light-tight". The above schedule for testing seems to be only dependent on the approval of this proposal.

Transport System Column - linac

General

Calculations on transport system continue. A computer program taking into account a homogeneous density distribution seems to be working now. Small differences has been found with TRAMP (a program without taking into account space charge defocussing); it is already clear that space charge defocussing for a homogeneous beam changes the quadrupole settings considerably for correct matching compared without space charge.

Components:

Solenoids are still in the drafting office, but this will be finished rather soon.

The power supplies should be available at the end of September.

Emittance Devices

We prepare two of them:

- a) The simple photo detection as it exists already in the preinjector (together with transformer and Faraday Cage).
- b) A fast emittance device, which will also be used as a mass analyser (see fig. 5).

Short description of this device:

Two slits (one in front of and the other after a ferrite coil) move with a speed of 2 1/2 mm/sec. along the beam; each time the beam passes the first slit the analyser sweeps the beam across the second slit, which tells you the optimum angles in the beam at that position of the slit; this information is fixed on a high-persistence scope; in 20 seconds the slits have traversed the beam and the emittance has been measured. By offsetting the second slit 1" and an adequate increase of the magnetic field (up to 1500 gauss) one determines the H_2 component in the beam.

Emittance Detector at 50 MeV

Components

- a) Magnets: sampler and analyser checked and they are adequate for our purpose. A second sampler can be made; a second analyser should be 4 cm inner bore and 5 1/2" long; material has been ordered.
- b) Slits (the most complicated part of the mechanical layout) are designed and in the workshop.
- c) Other hardware is still in the drafting office, but should not involve too much delay; in the beginning of September we expect the device ready to install.
- d) Electronics: this was a bit disappointing for the writer; but after all some more optimistic sounds could be heard half an hour later in the lobby: the electronics will not delay the start of the fast detector in the machine!

Work Allocation Concerning Pre-injector

Our own technicians allocated to hp (high priority) jobs will not be used for other work until that particular job is finished.

Rudy Damm

- hp 1. Short column resistances.
2. Solenoid.
3. Second operational duoplasmatron + adaption to test facilities.
4. Fast emittance detector at 50 MeV.
5. Slow emittance detector for Harold Wroe.
- hp 6. Spare column.

Gene Glittenberg

1. P.I.G. - Duoplasmatron Unit.
2. Density distribution facility for Harold.
3. Fast emittance detector at 750 KeV.

Bob Larson

Power supplies for a) Solenoids in pre-injector.
b) Quadrupoles in inflector.

Bob Lockey

Source electronics.

Art Otis

Electronics for fast emittance detectors.

Bill Schneider

- hp 1. Short column assembling
2. Dome assembling
3. High voltage building
4. Column vacuum equipment
5. Photographic emittance device for 750 KeV.

Andy Soukas

- hp 1. H.V. tests (columns and bananas).
- 2. Connection dome - H.V. stack + measuring resistances etc.
- hp 3. H.V. building.
- hp 4. R.D.I. power supply.

cc: A. Soukas
W. Schneider
R. Damm
G. Glittenberg
R. Lockey
A. van Steenbergen
A. Otis
H. Wroe
R. Larson
V. Racaniello
R. Lane
J. Keane

CONFIGURATION 1A

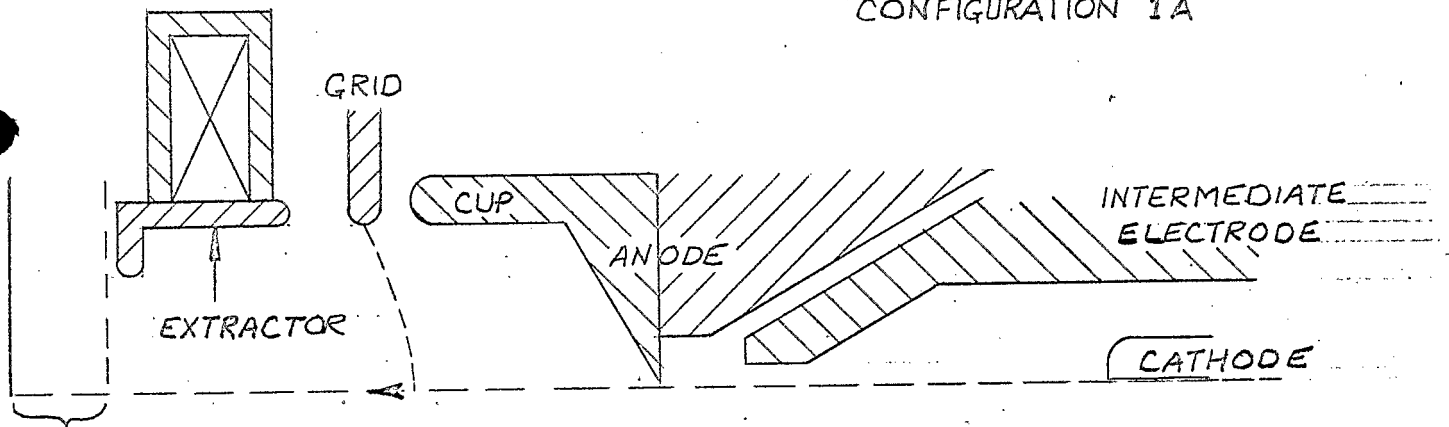

EMITTANCE
DETECTOR

1B

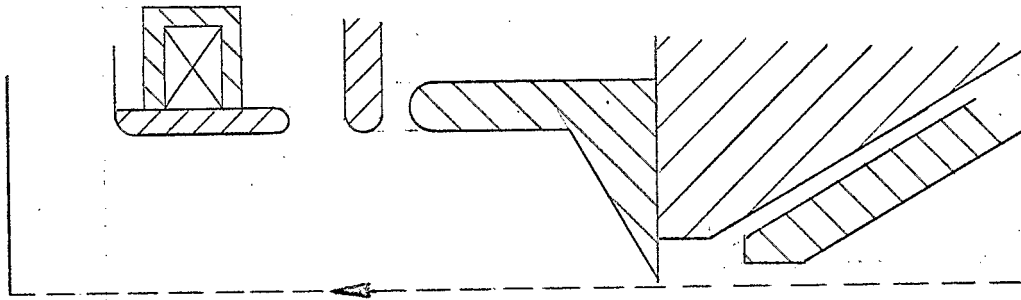

1C

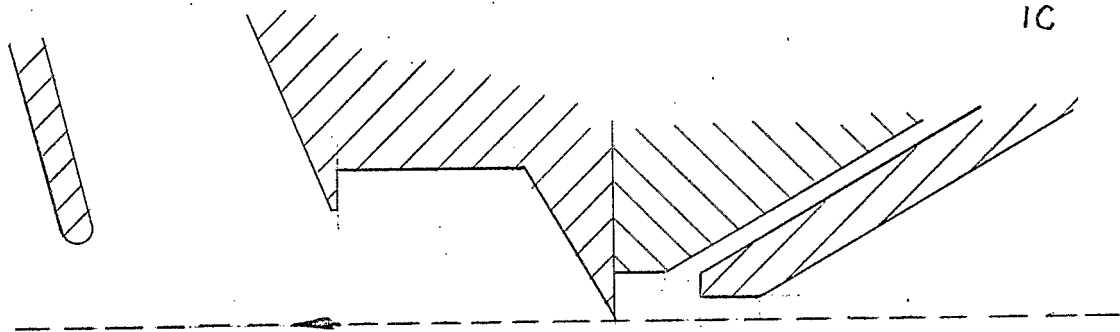

FIG. 1 DUOPLASMATRON

EXTRACTION GEOMETRIES

OPERATING TEMPERATURE OF RCA CATHODES

IN SUPPLEMENTARY SOURCE AS A FUNCTION OF

HEATER CURRENT & GAS PRESSURE

Cathode Temperature °C

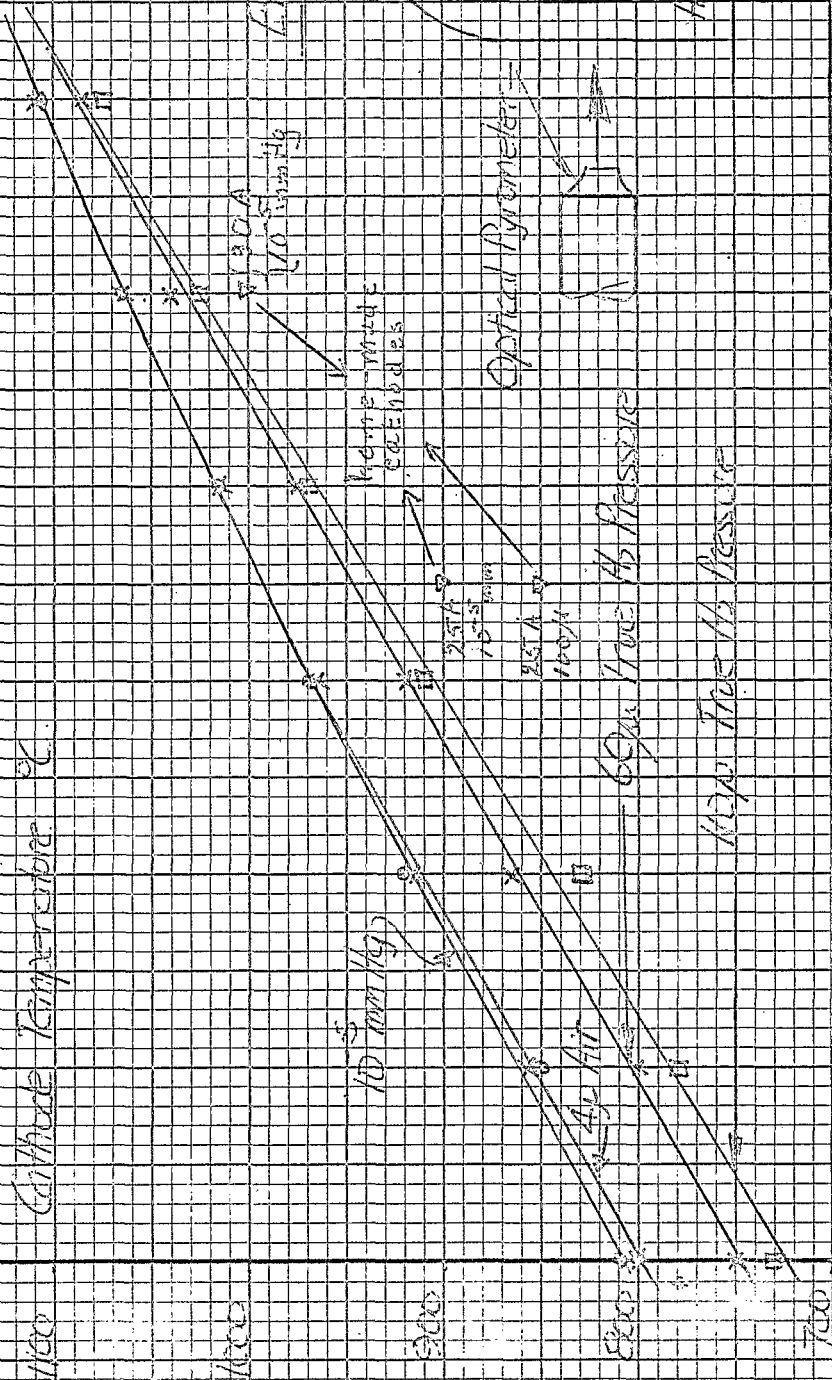

Experimental Setup

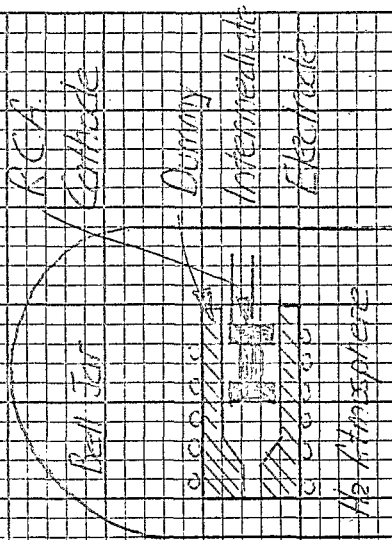

10 11 12 13 14 15 16 17

Fig. 2
 Heater Current (mA)

H. Moore & N.E.
 June 18, 65

W.J. SCHWENKER
7-13-65

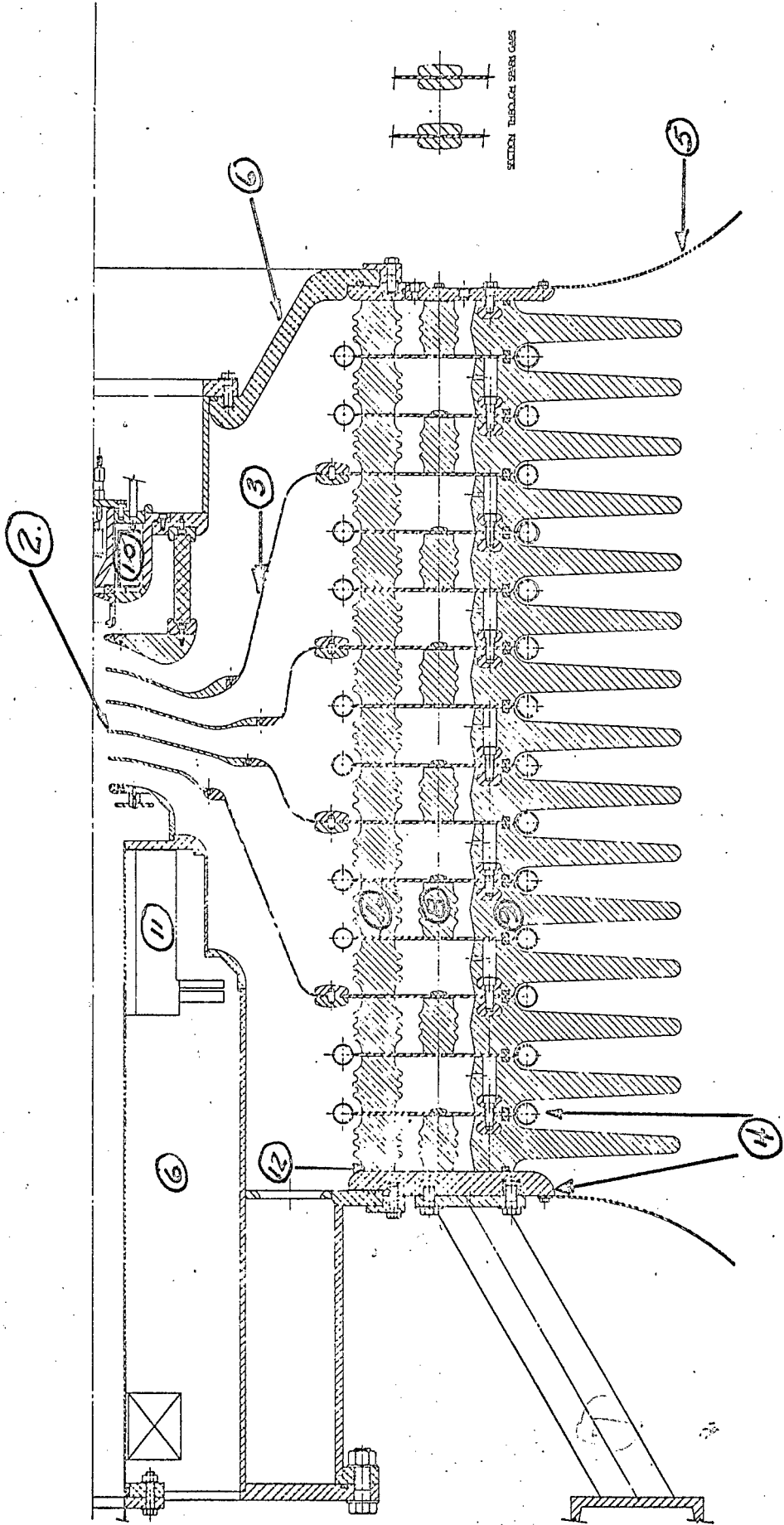

High Gradient Accelerator Column

Fig. 3

BY _____ DATE _____
CHKD. BY _____ DATE _____

SUBJECT SF6 SYSTEM
ARRANGEMENT
DEPT. OR PROJECT _____

SHEET No. 1 OF 1
JOB No. _____

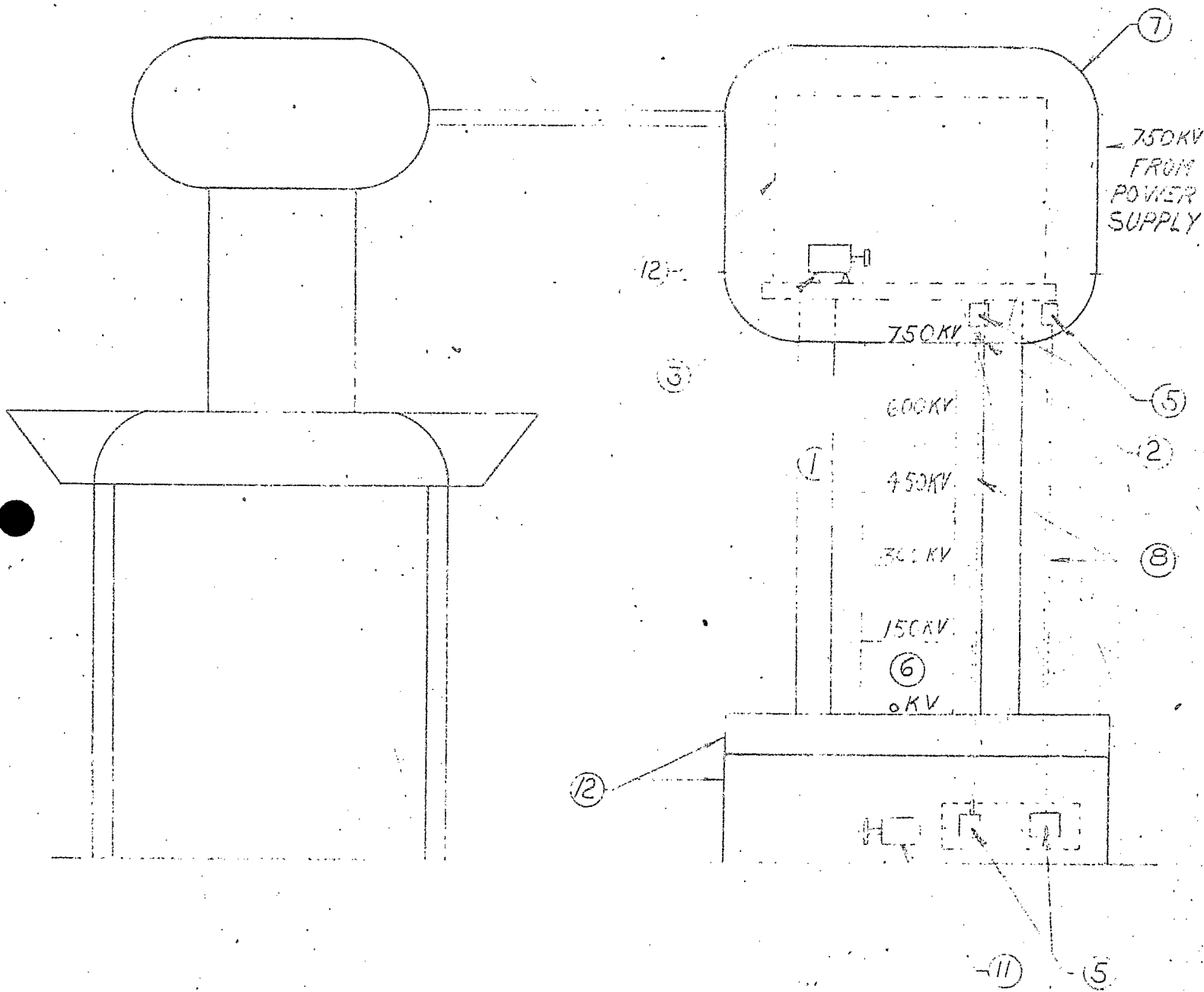

FIGURE - ~~X~~ ^H

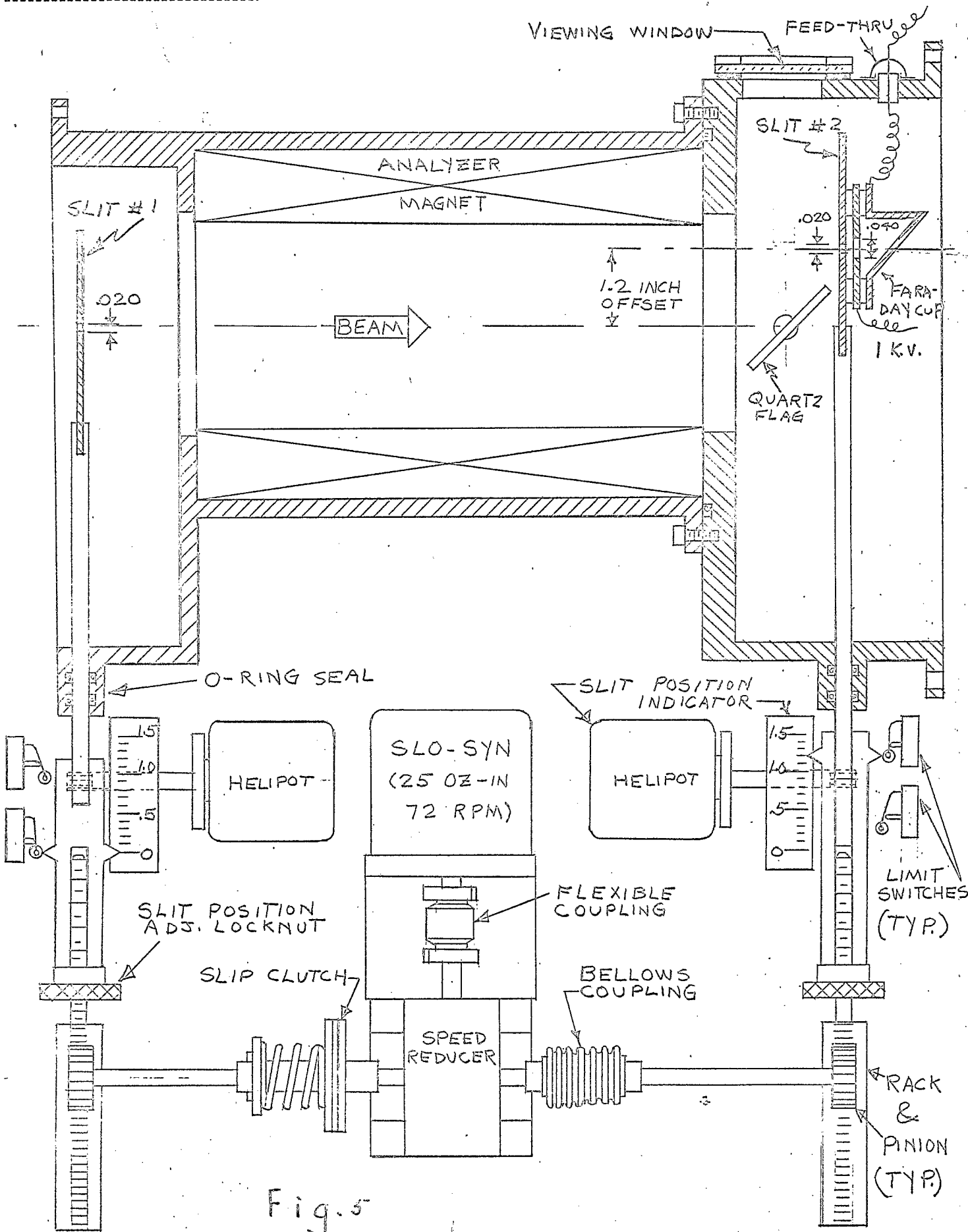

Fig. 5