



BNL-96411-2011-TECH

BNL-96411-2011-IR

Camera assembly design proposal for SRF cavity image collection

S. Tuozzolo,

October 2011

Collider Accelerator Department
Brookhaven National Laboratory

U.S. Department of Energy

USDOE Office of Science (SC)

Notice: This technical note has been authored by employees of Brookhaven Science Associates, LLC under Contract No. DE-AC02-98CH10886 with the U.S. Department of Energy. The publisher by accepting the technical note for publication acknowledges that the United States Government retains a non-exclusive, paid-up, irrevocable, world-wide license to publish or reproduce the published form of this technical note, or allow others to do so, for United States Government purposes.

DISCLAIMER

This report was prepared as an account of work sponsored by an agency of the United States Government. Neither the United States Government nor any agency thereof, nor any of their employees, nor any of their contractors, subcontractors, or their employees, makes any warranty, express or implied, or assumes any legal liability or responsibility for the accuracy, completeness, or any third party's use or the results of such use of any information, apparatus, product, or process disclosed, or represents that its use would not infringe privately owned rights. Reference herein to any specific commercial product, process, or service by trade name, trademark, manufacturer, or otherwise, does not necessarily constitute or imply its endorsement, recommendation, or favoring by the United States Government or any agency thereof or its contractors or subcontractors. The views and opinions of authors expressed herein do not necessarily state or reflect those of the United States Government or any agency thereof.

C-A/AP/#434

Oct. 2011

Camera assembly design proposal for SRF cavity image collection

S. Tuozzolo



**Collider-Accelerator Department
Brookhaven National Laboratory
Upton, NY 11973**

Notice: This document has been authorized by employees of Brookhaven Science Associates, LLC under Contract No. DE-AC02-98CH10886 with the U.S. Department of Energy. The United States Government retains a non-exclusive, paid-up, irrevocable, world-wide license to publish or reproduce the published form of this document, or allow others to do so, for United States Government purposes.

Camera Assembly Design Proposal for SRF Cavity Image Collection

Stephen Tuozzolo

I. Introduction

This project seeks to collect images from the inside of a superconducting radio frequency (SRF) large grain niobium cavity during vertical testing. These images will provide information on multipacting and other phenomena occurring in the SRF cavity during these tests. Multipacting, a process that involves an electron buildup in the cavity and concurrent loss of RF power, is thought to be occurring near the cathode in the SRF structure (see Figure 1). Images of electron emission in the structure will help diagnose the source of multipacting in the cavity. Multipacting sources may be eliminated with an alteration of geometric or resonant conditions in the SRF structure.¹ Other phenomena, including unexplained light emissions previously discovered at SLAC, may be present in the cavity.² In order to effectively capture images of these events during testing, a camera assembly needs to be installed to the bottom of the RF structure. The SRF assembly operates under extreme environmental conditions: it is kept in a dewar in a bath of 2K liquid helium during these tests, is pumped down to ultra-high vacuum, and is subjected to RF voltages. Because of this, the camera needs to exist as a separate assembly attached to the bottom of the cavity. The design of the camera is constrained by a number of factors that are discussed below.

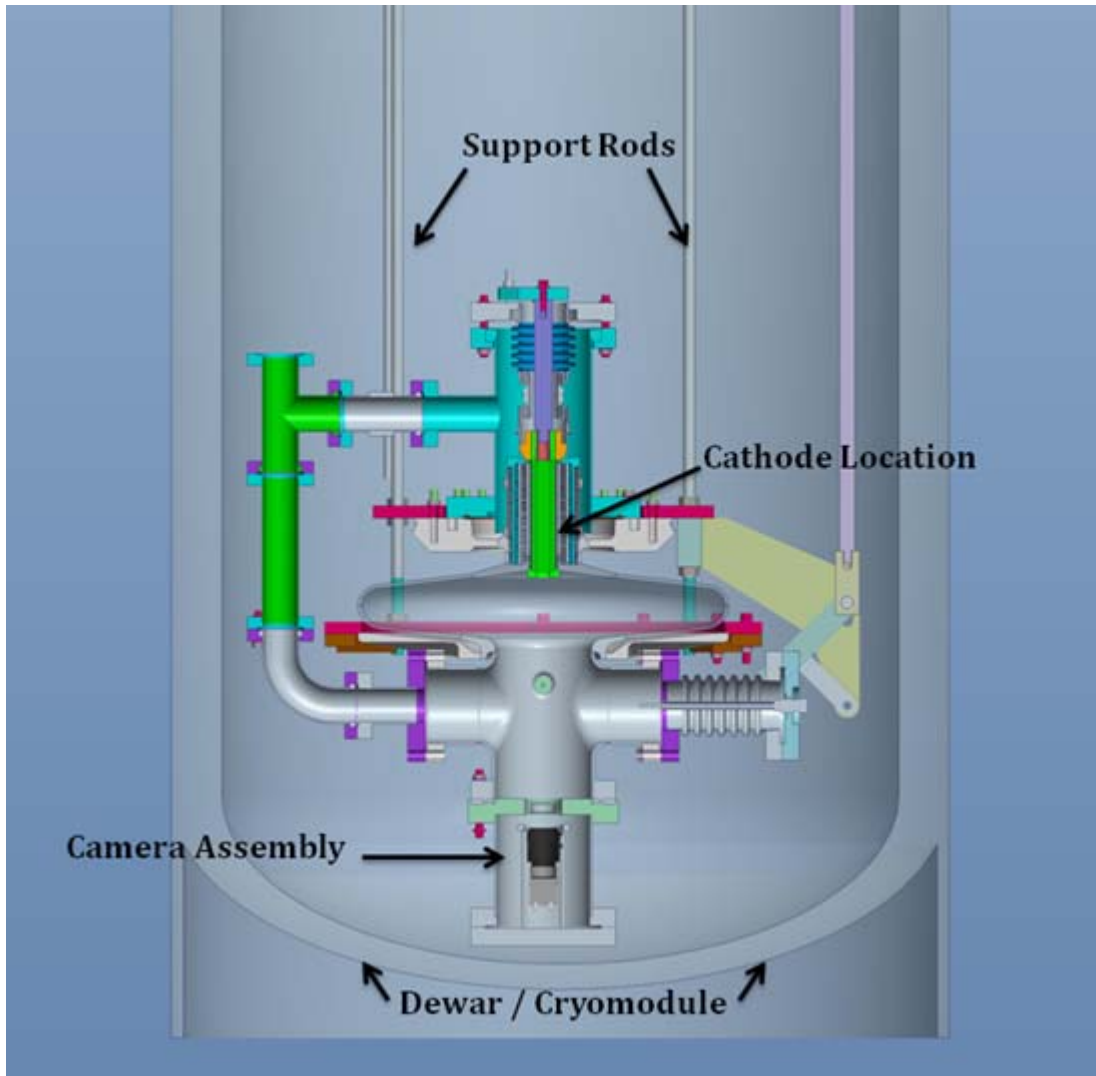

Figure 1: SRF Cavity

II. Assembly Requirements

1. Basic Constraints

The following constraints need to be met for this assembly:

- a) The camera assembly must fit inside the existing SRF test assembly. Currently, the cavity and its associated parts sit inside a large dewar filled with liquid helium. The cavity is suspended from a top plate, and the camera section will be attached to the bottom of the cavity (see Figure 1). The height of the camera

assembly must be kept to a minimum, as it adds to the height of the assembly. Because the liquid helium level in the dewar slowly drops due to burn off, once helium level drops below the top of the cavity the tests must stop. If the camera adds significantly to the height of the assembly, the cavity itself will need to be raised in the cryomodule. This would reduce the experimental time.

- b) The camera needs an unobstructed view of events occurring inside the large grain cavity during vertical testing
- c) The camera needs to be able to operate in the assembly which is cooled to 2K.
- d) The camera assembly needs to be under rough/insulating vacuum.
- e) The camera assembly should not contribute to excess heating of the cryogenic system. This would increase the burn off rate of helium and shorten the experimental time.

2. Viewport Requirements

In order for the camera assembly to be able to see into the SRF cavity during tests, a viewport must be installed on a flange at the bottom. Sapphire was chosen as the material because it has an appropriate transmission range (0.25- 4.50 μm) and high temperature tolerance if the cavity needs to be baked out (up to 450°C). Because the flange at the bottom of the assembly is not a standard conflat, and because the window diameter can be small, 1" a sapphire window would be welded into a custom flange.

3. Thermal Requirements

Thermal radiation and conduction are the two primary heat sinks for the camera. Technical specifications suggest that the camera has an operating temperature of 273K to 323K, but the performance of a camera's CCD is optimized at low temperatures when dark current is kept to a minimum. Because the camera is not rated to operate at cryogenic temperatures, the camera will be installed with a flexible heater and insulation to ensure operation inside the cryogenic assembly, which is cooled to 4K for testing. The camera will

be kept at around 253K, or whatever low temperature allows for maximum performance and smooth operation.

III. Assembly Design

The camera is mounted inside of a cylindrical section of stainless steel, which is then attached to the bottom of the existing gun assembly with the custom flange. This cylindrical section sits right above the bottom of the dewar, and the camera is oriented to face up directly into the RF cavity and cathode. The camera looks through a 1" diameter sapphire window that is welded into a flange. This window separates the high vacuum and uncontaminated RF cavity from the low vacuum camera cavity.

The camera itself is mounted to the bottom of the spool section, but is mounted in a way such that heat losses through conduction can be minimized. This is accomplished by using G10 fiberglass rods for support and by designing the camera mount such that the path length for heat is significantly longer than what would be obtained with mounting the camera directly to the walls or floor of the assembly. The camera has a small flexible heater (rated to 25 watts) attached to its body, and is wrapped in super-insulation. A thermocouple is placed on the inside of the insulation to monitor camera temperature. This thermocouple feeds back to a temperature controller which is located on the outside of the helium container. All wires and cords for the electronics associated with the camera are fed out of the spool through a port which also serves as a vacuum. Wires are fed through flexible metal tubing to the outside of the helium container, and where they pass through a tee-pipe. The wires connect to the outside via a multi-pin feedthrough on one arm of the tee, and the vacuum pump is attached to the other arm of the tee. Figure 2 shows the basic cavity design, with attached dimensions.

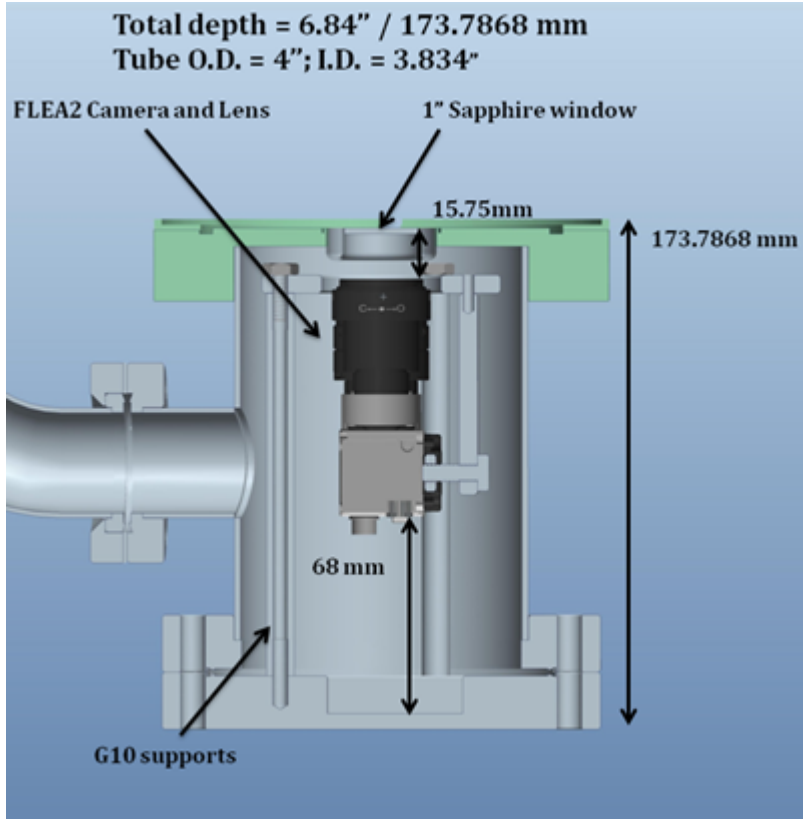

Figure 2: Camera Cavity Design

IV. Heat Calculation

The heat losses from the camera can be considered in two parts: heat loss from radiation, mostly through the exposed lens, and heat losses from conduction through the camera's supports. Use of super-insulation reduces heat transfer significantly, and can achieve a thermal conductivity as low as $1.0 \times 10^{-5} \text{ W}/(\text{m}\cdot\text{K})$ between temperatures of 300K and 20.3K.³

1. Radiation

Radiation heat transfer between two parallel, coaxial disks of radius 1.3 cm and 4.9 cm was calculated. The temperature of camera lens was set at 0°C (273K) for the calculation, and the flange was assumed to be at cryogenic temperature. The temperature

of the flange and window was assumed to be 4K. Using the following equation for ideal radiators, and with emissivities equal to $\epsilon_1 = 0.95$ $\epsilon_2 = 0.70$, and Q_{1-2} equal to the heat transferred between the camera and the flange,

$$Q_{1-2} = A_1 F_{1-2} (\epsilon_1 \sigma T_1^4 - \epsilon_2 \sigma T_2^4)$$

where the radiation shape factor, F_{1-2} , is equal to

$$F_{1-2} = \frac{1}{2} \left\{ X - \left[X^2 - 4 \left(\frac{R_2}{R_1} \right)^2 \right]^{\frac{1}{2}} \right\}$$

and,

$$R_1 = \frac{r_1}{a}, \quad R_2 = \frac{r_2}{a}.$$

Heat transfer calculations yielded a result of between 350 and 450 mW, depending on the distance between the lens and the flange. This value is a slight overestimate, as actual radiation during experiments will be lower if the camera can be kept at a temperature less than 273K.

2. Conduction

Heat conduction values were calculated by hand and through ANSYS analysis. Hand calculations used Fourier's Law of Conduction:

$$q_x = -kA_x \frac{\partial T}{\partial x}$$

where q_x is the rate of heat transfer through a finite area A in the direction of x , and k is a value of thermal conductivity, which changes with temperature. Figure 3 shows the temperature dependent thermal conductivities of G10 and stainless steel.

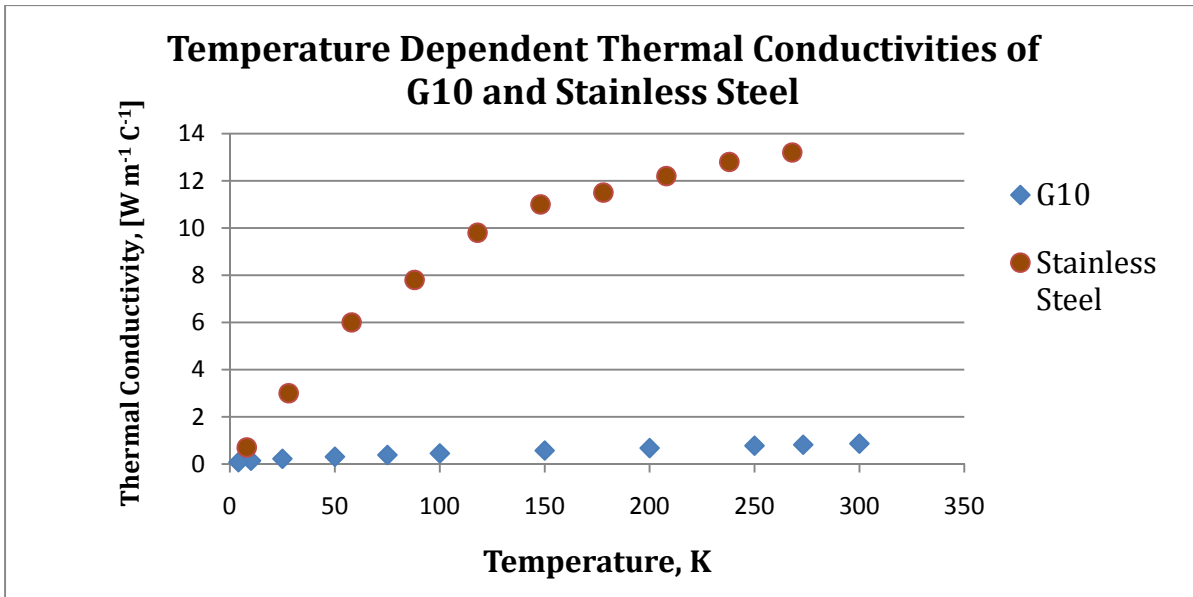

Figure 3: Temperature Dependent Thermal Conductivities⁴

The initial design called for using stainless steel supports for the camera. However, hand calculations found that heat losses would exceed 2 W, and alternative materials were considered. G10 and structural Teflon both have high strength-to-thermal conductivity ratios when compared to steel, and due to the availability G10 rods from vendors, G10 was chosen as the choice material. An ANSYS conduction heat transfer calculation was done, assuming G10 rods and stainless steel plates supported the camera. Conduction heat losses of the new design were estimated to be 166 mW using ANSYS; however, this still assumed some use of stainless steel in the support structure; replacing that with G10 could likely further reduce heat loss due to conduction. In any case, it provides significant heat loss savings over using stainless steel. Figure 4 is a visualization of the ANSYS calculation.

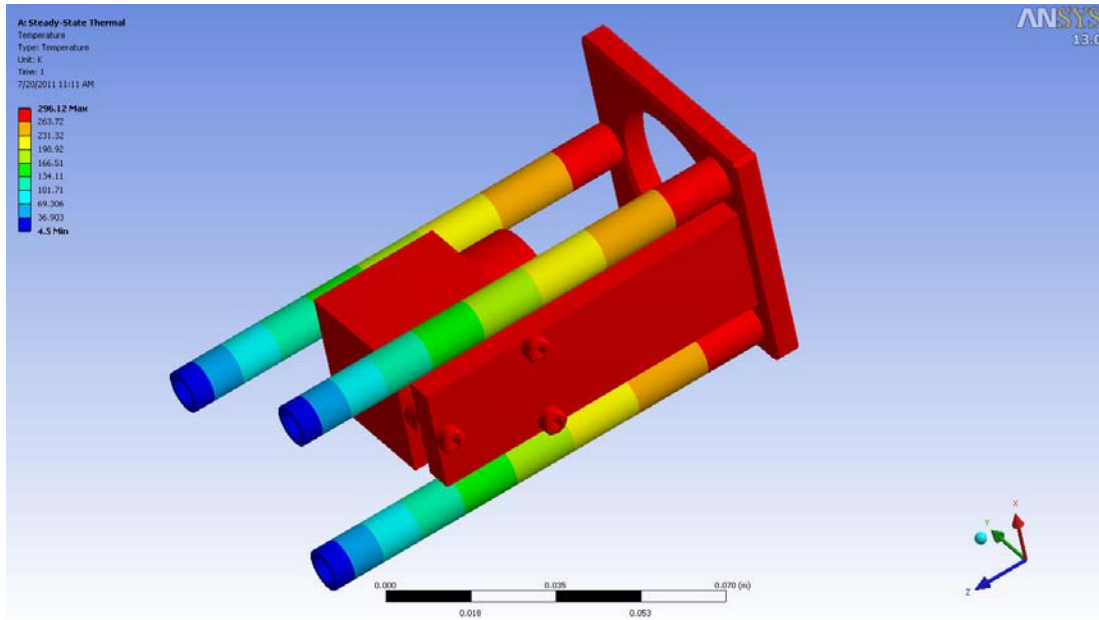

Figure 4: ANSYS Thermal Calculation

V. Camera Details and Placement

The FLEA2 is a very small 1394b camera with dimensions $29 \times 29 \times 30$ mm. It fits easily into the cylindrical section.⁵ The camera, shown in Figure 4, can record up to 15 fps video and provide 1392×1032 pixel resolution. A 35mm lens is attached to the camera, and aligned such that the lens faces towards the top of the assembly. The Firewire port lies on the bottom. Drawings for the 9-pin port were obtained, and it was determined that the space needed below the camera was 38 mm for the port and 30 mm for the wire bend radius. This constraint forced a deepening of the overall assembly section. The other constraints for space were the length of the camera and lens; since these were unchangeable, there was a fixed minimum depth for the spool section. In order to reduce the overall depth, small alterations introduced to the flanges; on the bottom flange, creating a narrow depression would provide extra space for the wire to bend, while on the top flange a circular depression would allow us to push the camera lens as close to the window as possible. Figure 1 shows some dimensions of the camera assembly.

VI. Other Considerations

The camera will be tested while in the cavity but before the SRF tests begin. Testing will take place to ensure that the camera is working properly and can record images in the cavity environment. To test the camera, a light needs to be introduced to the assembly. A small LED light can be affixed to the camera lens and pointed at the sapphire window. Reflecting light from the window and the sides of the assembly should be able to reach the camera lens and provide proof of operation.

At the top of the dewar, it is suggested to have a single multi-pin feedthrough for all of the electronic components of the camera. These components are a) one LED light, b) one thermocouple, c) one flexible heater, and d) one FLEA2 camera. Using a conventional instrumentation feedthrough for a thermocouple may introduce some error in the temperature calculation because different electrical properties of the feedthrough alloy and the thermocouple alloy will affect the temperature signal. However, because the temperature values need not be exact, it was decided to use one feedthrough as it reduces cost reduces hardware cluttering on the top of the SRF assembly.

VII. Conclusion

Placing a camera below a SRF cavity during testing has been done before, but each experimental assembly has its own specific requirements and design constraints, necessitating this project. The camera assembly presented here should be able to record phenomena occurring in much of the SRF structure during vertical tests. Provided heat losses are low and camera operation is reliable, this design offers a simple, straightforward, and cost-effective approach to recording multipacting and other phenomena inside SRF structures.

¹ Hasan Padamsee, Jens Knobloch, Tom Hays, *RF Superconductivity for Accelerators*, 2nd Ed. (Weinheim: Wiley-VCH, 2008), 197

² Anthony, P.L.; Delayen, J.R.; Fryberger, D.; Goreec, W.S.; Mammosser, J.; Szalata, J.M.; Weisend, J.G.; Experimental studies of light emission phenomena in superconducting RF cavities. SLAC PUB-13664 (June 2009): 1-4.

³ Thomas Flynn. *Cryogenic Engineering*. (New York: Marcel Dekker, Inc. , 1997), 396

⁴ I. Estermann, J.E. Zimmerman, Heat Conduction in Alloys at Low Temperatures. *Journal of Appl. Phys.* 23, 578-588 (1952)

⁵ Point Grey Systems, *Flea2 CCD 800 Firewire Cameras*.

http://www.ptgrey.com/products/flea2/flea2_firewire_camera.asp, (Accessed 7/26/11)