

Design of a modified Halbach magnet for the CBETA Project

N. Tsoupas

January 2018

Collider Accelerator Department
Brookhaven National Laboratory

U.S. Department of Energy

USDOE Office of Science (SC), Nuclear Physics (NP) (SC-26)

Notice: This technical note has been authored by employees of Brookhaven Science Associates, LLC under Contract No. DE-SC0012704 with the U.S. Department of Energy. The publisher by accepting the technical note for publication acknowledges that the United States Government retains a non-exclusive, paid-up, irrevocable, world-wide license to publish or reproduce the published form of this technical note, or allow others to do so, for United States Government purposes.

DISCLAIMER

This report was prepared as an account of work sponsored by an agency of the United States Government. Neither the United States Government nor any agency thereof, nor any of their employees, nor any of their contractors, subcontractors, or their employees, makes any warranty, express or implied, or assumes any legal liability or responsibility for the accuracy, completeness, or any third party's use or the results of such use of any information, apparatus, product, or process disclosed, or represents that its use would not infringe privately owned rights. Reference herein to any specific commercial product, process, or service by trade name, trademark, manufacturer, or otherwise, does not necessarily constitute or imply its endorsement, recommendation, or favoring by the United States Government or any agency thereof or its contractors or subcontractors. The views and opinions of authors expressed herein do not necessarily state or reflect those of the United States Government or any agency thereof.

DESIGN OF A MODIFIED HALBACH MAGNET FOR THE CBETA PROJECT*

N. Tsoupas, J.S. Berg, S. Brooks, G. Mahler, F. Méot, S. Peggs, V. Ptitsyn, T. Roser, S. Trabocchi, D. Trbojevic, J. Tuozzolo

Brookhaven National Laboratory

tsoupas@bnl.gov; jsberg@bnl.gov; mahler@bnl.gov; fmeot@bnl.gov; peggs@bnl.gov; vadimp@bnl.gov; rosler@bnl.gov; trbojevic@bnl.gov; strabocchi@bnl.gov; tuozzolo@bnl.gov

D. Burke, J. Crittenden, C. Mayes

Cornell University

dcb282@cornell.edu; crittenden@cornell.edu; christopher.mayes@cornell.edu

ABSTRACT

A modified Halbach magnet has been designed to be installed in the splitter/merger section of the CBETA project which is under construction at Cornell University. The splitter/merger of the CBETA consists of 4 beam lines and is shown in Fig. 1. Two of the functions of the splitter/merger lines are; first to match the beam parameters at the exit of the Energy Recovery Linac (ERL) to those at the entrance of the Fixed Field Alternating Gradient (FFAG) arc, and second to place the trajectories of the reference particles of the beam bunches at the entrance of the FFAG arc on specified trajectories as they determined by the beam optics of the FFAG arc. In this technical note we present results from the 2D and 3D electromagnetic analysis of the S4.BEN01 magnet which is one of the dipole magnets of the 150 MeV line of the splitter/merger. The present design of the S4.BEN01 magnet, is based on a modified Halbach-type permanent magnet. To justify our suggestion of using a Halbach type of magnet instead of an electromagnet for the S4.BEN01 magnet we devote an APPENDIX A in which we provide details on the design of an electromagnet for the S4.BEN01 magnet and in the section under conclusion will list the pros and cons of the two designs.

KEYWORDS

ERL, FFAG, Halbach magnet

1. INTRODUCTION

The splitter/merger section of the CBETA project [1] consists of 4 beam lines as shown in Fig. 1. Two of the functions of the splitter/merger lines are; first to match the beam parameters at the exit of the Energy Recovery Linac (ERL) to the beam parameters at the entrance of the Fixed Field Alternating Gradient (FFAG) arc, and second to place the reference particles of the beam bunches at the entrance of the FFAG arc on specified trajectories which are determined by the beam optics of the FFAG arc. In this technical note we are presenting results from the 2D and 3D

electromagnetic analysis of the S4.BEN01 magnet which is one of the dipole magnets of the 150 MeV line of the splitter/merger.

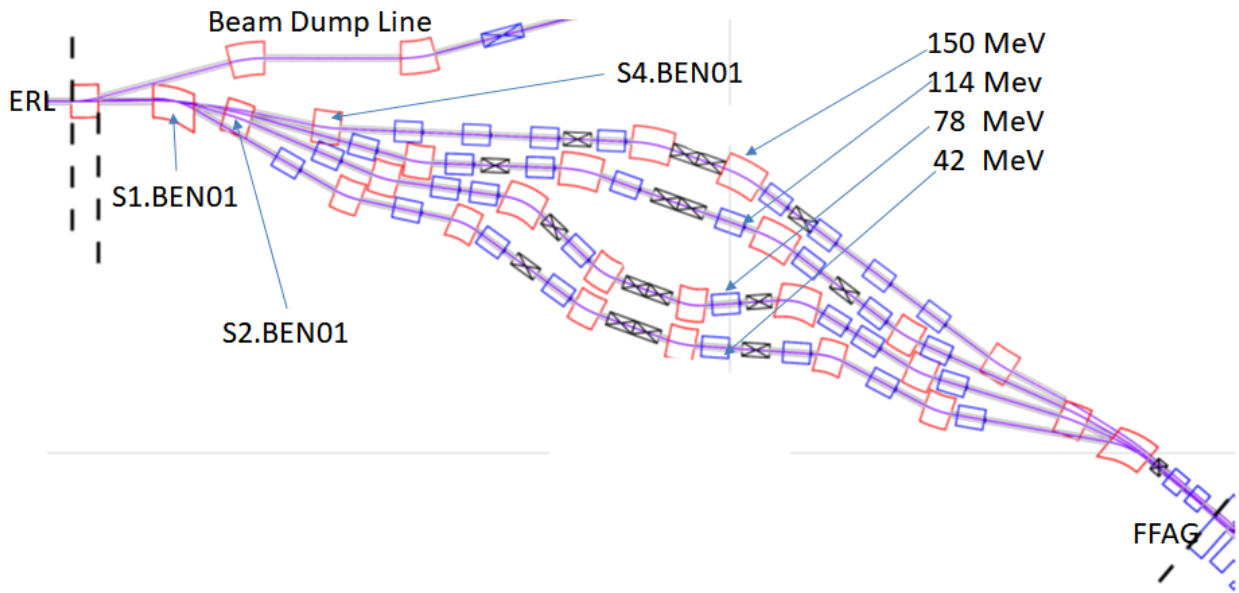

Figure 1. The four beam lines of the SBETA splitter. The 150 MeV line's S4.BEN01-magnet which is the study of this technical note is shown in the figure.

The design of the magnet depends partly on the geometry of the beam trajectories of the two reference particles, namely the 114 MeV and 150 MeV, at the region of the S4.BEN01 magnet. These trajectories have been obtained from the survey file which was generated from the beam optics of the splitter line by using the BMAD computer code [2]. These trajectories are shown in Fig. 2 as the two colored traces which are labelled with the values of the beam energies. The coordinates of the reference particles at the entrance and exit of the magnet are at the center of the blue circles in Fig. 2 and their numerical values of the coordinates appear in the last six columns of Table I. The center of the blue circles in Fig. 2 represent the reference particles of the 114, and 150 MeV bunches and these reference particle should be at least 1.2 cm away from any material. In this technical note we consider a design based on a Halbach type permanent magnet [3] however we devote an APPENDIX A in which we provide details on the design of an electromagnet, for comparison between the two types of magnets, namely the Halbach type versus an electromagnet.

Table I. The kinetic energy of the two electron bunches and their angles of bend in the S4.BEN01 magnet. The coordinates of the reference particles of the 140 and 150 MeV bunches at the entrance and exit of the Halbach magnet appear in the last six columns.

| KE [GeV] | gamma | P [GeV/c] | Ang. Bend [deg] | Entrance coordinates | | | Exit coordinates | | |
|----------|---------|-----------|-----------------|----------------------|-----------------|--------------|------------------|------------------|---------------|
| | | | | x_{in} [m] | x'_{in} [deg] | z_{in} [m] | x_{out} [m] | x'_{out} [deg] | z_{out} [m] |
| 0.114 | 224.092 | 0.1145 | 0.0 | 12.34037 | -15.658 | 26.9709 | 12.30342 | -15.6578 | 27.10276 |
| 0.150 | 294.542 | 0.1505 | 9.30225 | 12.40000 | -11.895 | 26.9730 | 12.38302 | -2.59254 | 27.10101 |

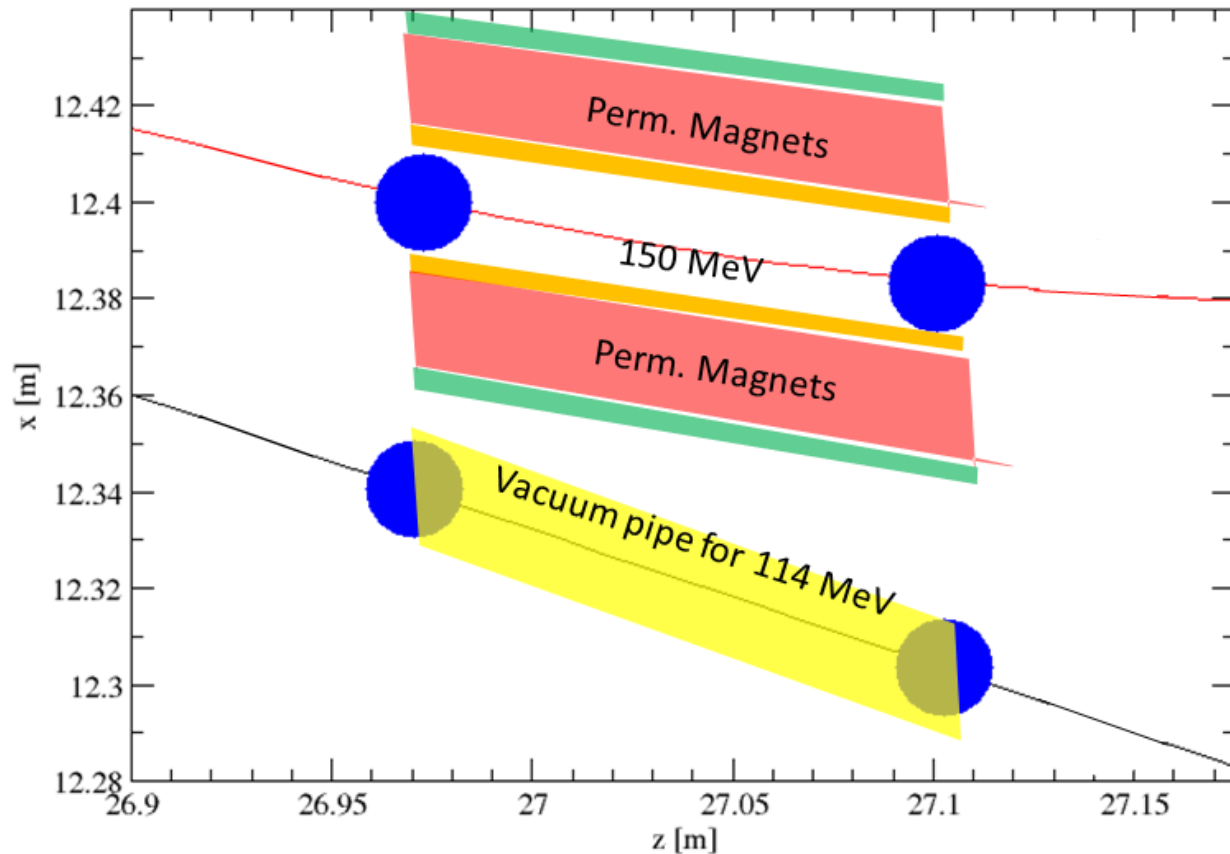

Figure 2. Schematic diagram of the cross section on the median plane of the 12 cm long Halbach magnet. The thin traces are the trajectories of the reference particles of the 114 and 150 MeV electron bunches on the median plane at the region of the S4.BEN01 magnet. The center of the blue circles on the figure represent the reference particles of the two bunches at the entrance and exit of the 12 cm long Halbach type dipole magnet.

2. THE S4.BEN01 HALBACH TYPE MAGNET

In this section we present the results of the study on a Halbach type dipole magnet made of permanent magnet material to replace the S4.BEN01 electromagnet discussed in the APPENDIX A. A comparison between the electromagnet and the Halbach type dipole magnet will be given in the “conclusion” section. All the results of the electromagnetic field calculations have been obtained by modeling the magnets and performing the electromagnetic field calculations using the OPERA computer code [4].

2.1. Geometric considerations for the design of the Halbach type magnet

Since the permanent magnet can provide stronger fields of ~ 0.67 T as compared to the field of the electromagnet 0.406 T (see APPENDIX A), we can use only a 12 cm long Halbach magnet instead of a 20 cm long electromagnet, and we can place the longitudinal center of the Halbach magnet at the same location as the electromagnet’s center to provide the same angle of bend and

trajectory for the 150 MeV electron bunch as for the electromagnet. Fig. 2 shows a schematic diagram of the cross section at the median plane of the Halbach type of magnet. The center of the blue circles are the global coordinates of the reference particles of the 114, and 150 MeV bunches at the entrance and exit of the 12 cm long Halbach magnet. The blue circles of radius 1.2 cm represents the transverse area around the reference trajectory which should be material free. Table I provides the coordinates of the reference particles of these bunches at the entrance and exit of the Halbach magnet. The orange stripes are the 0.2 cm thick walls of the vacuum chamber for the 150 MeV beam, and the green stripes is the retaining material of the permanent magnet material which is shown in red. The retaining material of the permanent magnets could be of magnetic material. The yellow quadrilateral shape is the 0.2 mm thick vacuum pipe of the 114 MeV beam. The pipe is made of magnetic material.

From the values of the coordinates shown in Table I we conclude that the distance between the trajectories of the central particle of the 114 MeV and the 150 MeV at the entrance of the magnet is 5.96 cm and their distance at the exit of the magnet is 7.96 cm. Given the constrain that the center of the beam bunch should be 1.2 cm from the inner surface of the vacuum chamber whose thickness can be ~2 mm, the available space for permanent magnet material is $=5.96 \text{ cm} - 2 \times 1.2 \text{ cm} - 3 \times 0.2 \text{ cm} = 2.96 \text{ cm}$. This distance of 2.96 cm can accommodate the permanent magnet material and also material in which water flows to maintain the temperature of the permanent magnet constant.

2.2. The 2D design of the Halbach magnet

In this section we present the 2D electromagnetic analysis of the alternative design of the S4.BEN01 electromagnet. This design is based on a Halbach type of magnet whose cross section is shown in Fig. 3 and is made of 16 permanent magnet wedges. The inner and outer radii of the Halbach annulus are 2.0 and 3.5 cm respectively and the magnet generates a field of 0.65 T. The inner radius of the Halbach magnet can easily accommodate a 2 mm thick vacuum chamber and satisfy the constrain imposed on the reference trajectory of the electron bunch to be 1.2 cm away from the wall of the vacuum chamber.

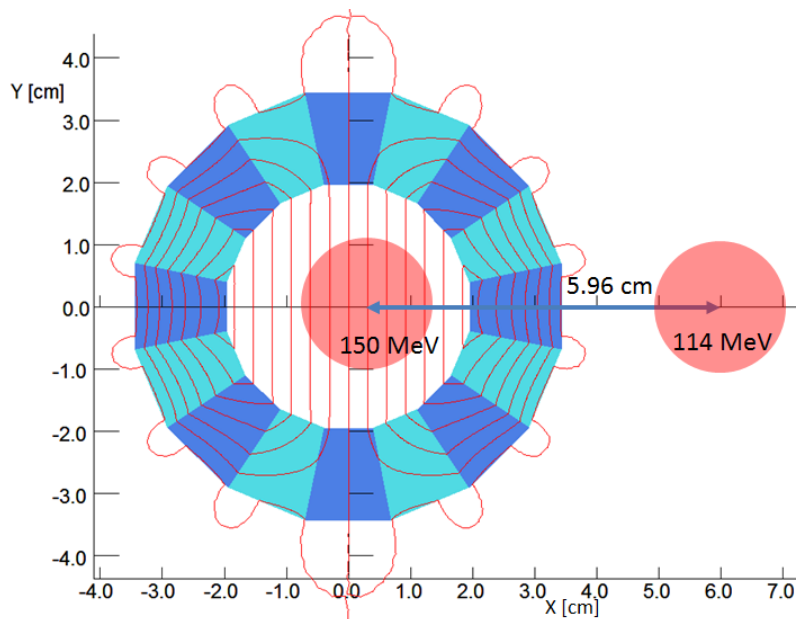

Figure 3. A Halbach type dipole magnet made of 16 permanent magnet wedges. The permanent magnet material used in the design is NdFeB_N35EH and the dipole field generated is 0.65 T. The red traces on the figure are the equipotential vector lines. The centers of the red circles which are at a distance of 5.96 cm, are the reference particles for the 114 and 150 MeV electron bunches.

The permanent magnet material used in the design of the magnet is NdFeB_N35EH and the dipole field generated by the magnet is 0.65 T. The red traces on Fig. 3 are the equipotential vector lines. The field uniformity within $x=\pm 1.5$ cm is better than 1.0×10^{-3} and is shown in Fig. 4. The reason we have set the field of the magnet at the value of ~ 0.65 T and not higher is that our manufacturer for permanent magnets can supply wedges of 6 cm long, and the integrated field of the 0.65 T, 2×6 cm long Halbach magnet generates the same integrated dipole field as the 20 cm long electromagnet we discussed in the APPENDIX A.

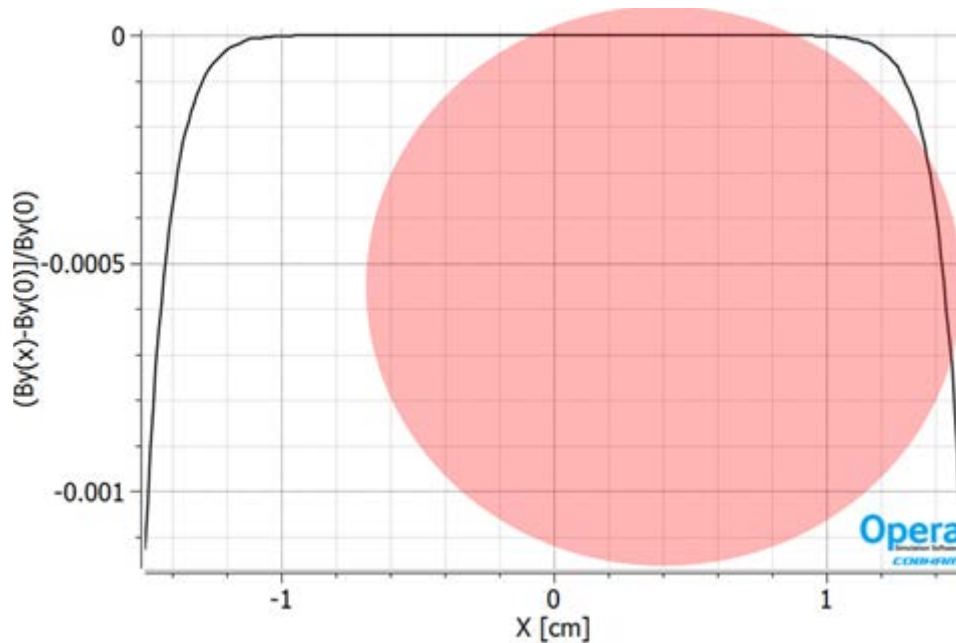

Figure 4. The dipole field homogeneity of the Halbach magnet in a range $x=\pm 1.5$ cm is better than 1×10^{-3} . The red circle is the 1.2 cm beam size which well within the 1×10^{-3} uniform region.

2.3. The 3D design of the 12 cm long dipole Halbach magnet

In this section we study the 3D design of the 12 cm long Halbach magnet. Figure 5 is an isometric view of the Halbach magnet which can generate the same integrated field as the 20 cm long S4.BEN01 electromagnet. The inner and outer radii are 2.0 and 3.5 cm respectively. The field homogeneity at the center of the magnet is shown in Fig. 6, and is better than 1×10^{-3} .

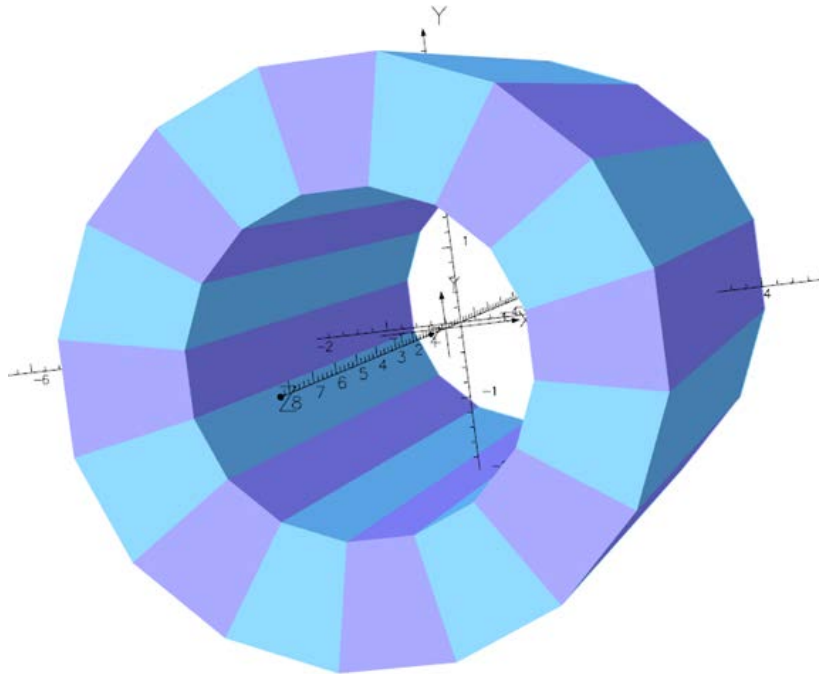

Figure 5. Isometric view of the 12 cm long Halbach magnet which can generate the same integrate dipole field as the 20 cm long S4.BEN01 electromagnet.

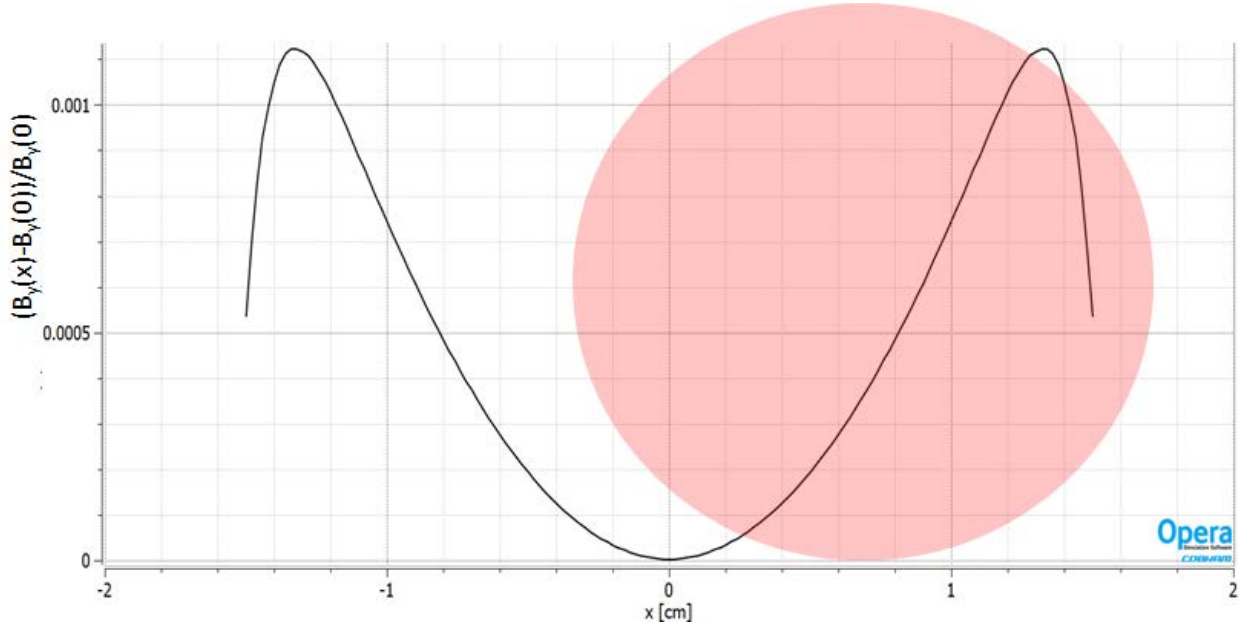

Figure 6. Field homogeneity halfway of the Halbach magnet. The red circle represents the 1.2 cm radius beam size which well within the 1×10^{-4} field uniformity.

The fringe field of the Halbach magnet along the trajectory of the 114 MeV beam which is shown in Figure 7 can be minimized by either, using magnetic material around the Halbach magnet or using a vacuum pipe for the 114 MeV beam made of magnetic material, or both.

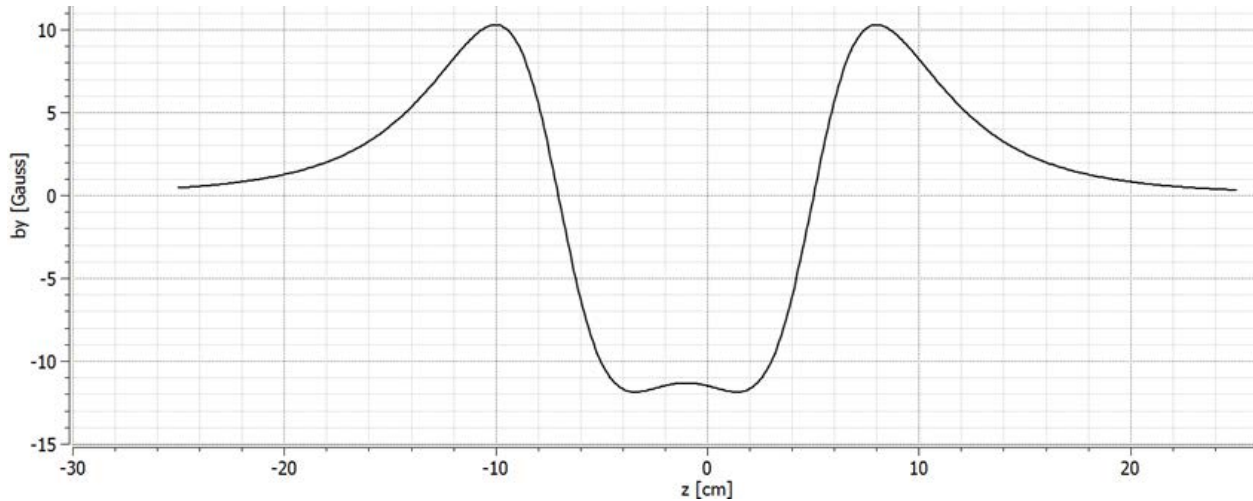

Figure 7. The magnetic field generated by the Halbach magnet along the 114 MeV trajectory. In this design no magnetic shield has been used at either around the Halbach magnet or around the vacuum pipe.

Although the Halbach magnet is less expensive to make and does not require the expensive power supply of the electromagnet, the Halbach magnet is prone to radiation damage from the 150 MeV electrons and any secondary particles generated by the interaction of the electron beam and the vacuum pipes. To minimize the effect of the radiation on the permanent magnet, Pb material of ~1.5 cm thick [5] can be placed in front of the permanent magnet material. Although 1.5 to 2 cm thick Pb material can stop the 150 MeV electron beam, the generation of neutrons from the interaction of the electrons with the Pb [6] is the most damaging effect of the permanent magnet material.

2.4. The 3D design of the 12 cm long modified dipole Halbach magnet

Although a Halbach dipole magnet as described earlier seems ideal to be used instead of an electromagnet, there are some objections in using such a magnet in an environment that is subject to radiation. To mitigate the effect of the radiation on the permanent magnet material was suggested [7] to remove the permanent magnet wedges from the horizontal plane and modify the design the Halbach magnet to provide a dipole field with acceptable homogeneity. An isometric view of such a modified dipole Halbach magnet is shown in Fig. 8 with the permanent magnet wedges on the horizontal plane removed and replaced by magnetic iron wedges. The holder of the permanent magnet wedges is made of magnetic material to minimize the magnetic field at the region of the 114 MeV beam. Similarly the vacuum pipe of the 114 MeV beam is made of magnetic material and is copper plated inside.

Following the suggestion [7] which will mitigate the effect of the radiation damage, the permanent magnet wedges were removed from the horizontal plane and were substituted with magnetic iron which is not affected by the radiation.

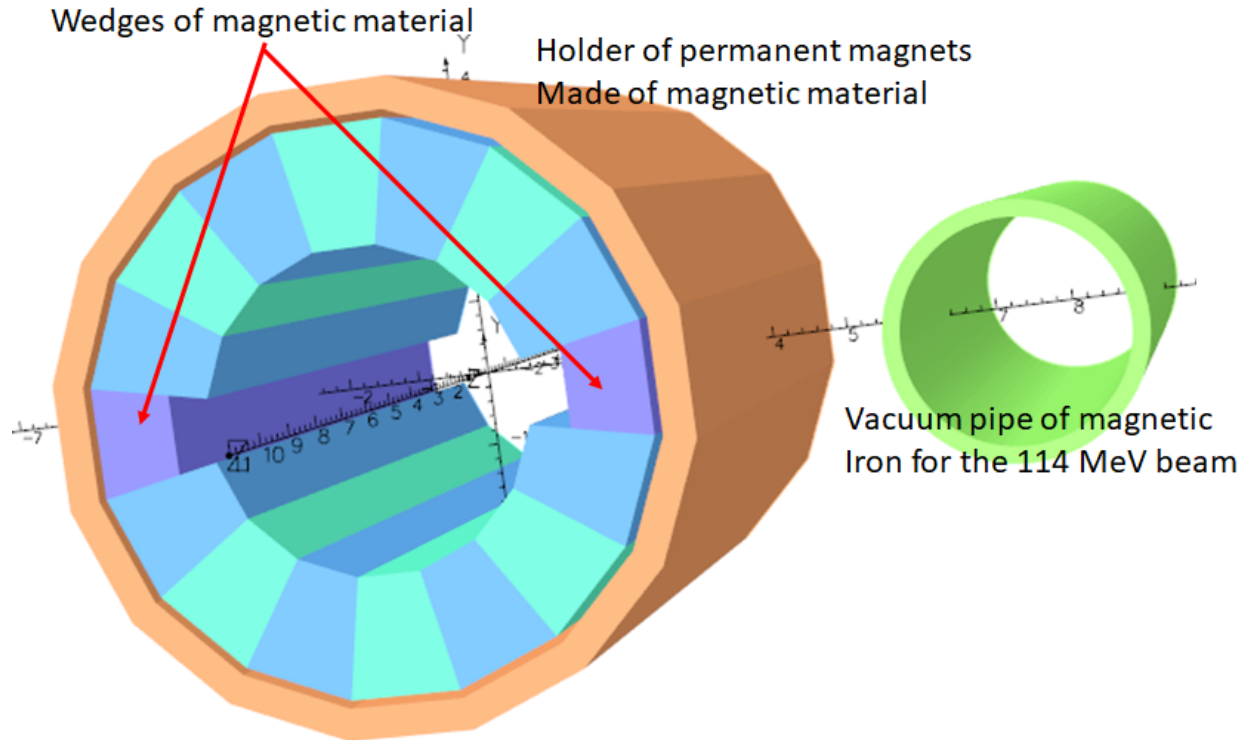

Figure 8. Isometric view of the modified Halbach magnet. The permanent magnet wedges on the horizontal plane have been removed and replaced by magnetic iron wedges. The ring which surrounds the permanent magnet wedges is the holder of the permanent magnet wedges and is made of magnetic iron. The vacuum pipe of the 114 MeV beam is made of magnetic iron and is copper plated inside.

The distance between the center of the Halbach magnet and the center of the vacuum pipe of the 114 MeV beam at the entrance of the magnet is 6.26 cm. There is space between the vacuum pipe of the 114 MeV beam and the ring-holder of the permanent magnet wedges for material to serve as cooling conductor to keep the temperature of the permanent magnet material constant. Table II lists some of the specifications of the Halbach magnet. The permanent magnet material is NdFeB_N35EH with remnant field of 1.2040 T and coercive field of -147.03 A/m.

Table II. The S4.BEN01 modified Halbach-type magnet specifications

| Length [m] | B_{field} [T] | Sagitta [cm] | R_{in} [cm] | R_{in} [cm] | PM Material | B_r [T] | H_c [A/m] |
|------------|------------------------|--------------|----------------------|----------------------|-------------|-----------|-------------|
| 0.12 | 0.65 | 0.12 | 2.0 | 3.5 | NdFeB_N35EH | 1.2040 | -147.03 |

The removal of the permanent magnet wedges affects adversely the homogeneity of the Halbach magnet's magnetic field. To restore the homogeneity of the dipole field we partly refill the empty spaces with magnetic iron wedges. In addition we also change the direction of the easy axis of the wedges. Table III list the magnetization direction of the easy axis of the wedges for a regular dipole Halbach magnet (2^{nd} row) which is given by the equation $\alpha = (n + 1)\theta + \frac{\pi}{2}$ (1) and

the magnetization direction (3rd row) of a modified dipole Halbach magnet which is shown on Fig. 8. In equation (1) the symbol α is the direction of the magnetization (easy axis) and the symbol θ is the azimuthal location of the wedge.

Table III. The magnetization direction of the easy axis of the wedges for a regular dipole Halbach magnet and a modified one.

| | | | | | | | | | |
|-----------------|------|---------|-------|---------|------|--------|------|--------|------|
| WedgeAngle=> | 0° | 22.5° | 45° | 67.5° | 90° | 112.5° | 135° | 157.5° | 180° |
| Regular Dipole | 270° | 315° | 0° | 45° | 90° | 135° | 180° | 225° | 270° |
| Modified Dipole | NA | 342° | 3° | 45° | 90° | 135° | 177° | 198° | NA |
| WedgeAngle=> | | | | | | | | | |
| WedgeAngle=> | | -157.5° | -135° | -112.5° | -90° | -67.5° | -45° | -22.5° | |
| Regular Dipole | | 315° | 0° | 45° | 90° | 135° | 180° | 225° | |
| Modified Dipole | | 342° | 3° | 45° | 90° | 135° | 177° | 198° | |

The direction of the magnetization axis of each of the wedges of the modified Halbach magnet as it appears in Table III generates a field homogeneity which is shown in Fig. 9. The red circle in Fig. 9 represents the 150 MeV beam, and shows that the field homogeneity of the modified Halbach magnet over the beam is better than 10^{-3} . The center of the 1.2 cm radius circle in Fig. 9 represents the reference particle of the 150 MeV bunch in the magnet. Further optimization of the modified Halbach magnet may further improve the field homogeneity.

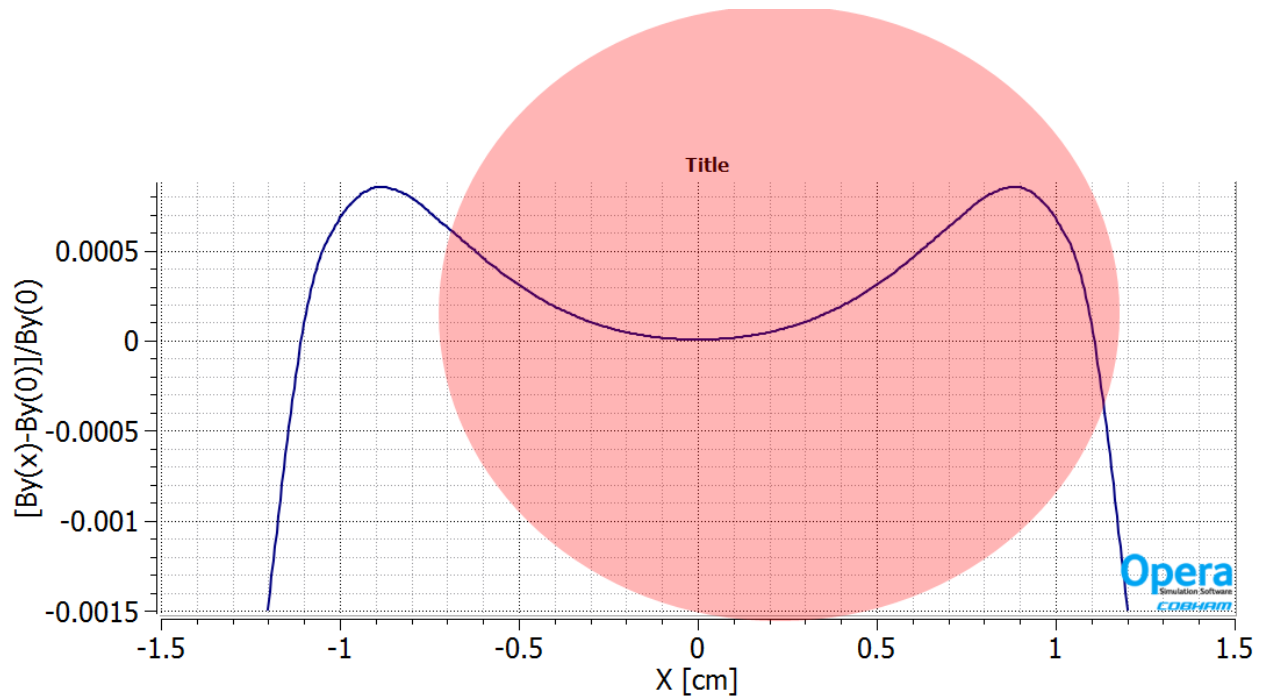

Figure 9. The field homogeneity of the modified Halbach magnet. The center of the 1.2 cm radius circle is the reference particle of the 150 MeV bunch which is inside the modified Halbach magnet.

3. A METHOD TO CORRECT THE MULTIPOLES OF A HALBACH MAGNET

The magnetic measurements of a Halbach magnet by a rotating coil provide the integrated values of the magnetic multipoles. Some of the measured multipoles are the results of misalignments of the permanent magnet wedges and/or the not accurate value of the easy axis of each of the wedges. We have developed a process, which is described below, to minimize those multipoles by using magnetic wires. This process is based on a paper [8] which suggests a method which affects the multipoles of an iron dominated magnet.

The method of minimizing the undesired magnetic multipoles is based on generating holes or slots along the perimeter of the inner aperture of the Halbach magnet as shown with the little circles in the left picture of Fig. 10 which is a cross section of a Halbach magnet. The holes or slots can accept magnetic wires which can modify the magnetic field of the Halbach magnet in such a way to eliminate the undesired multipole of the magnet. The right picture of Fig. 10 is a cross section of the same Halbach magnet with four of the holes (blue little circles) occupied by magnetic wires. It is understood that the holes or slots are made on a nonmagnetic material like the vacuum chamber of the magnet.

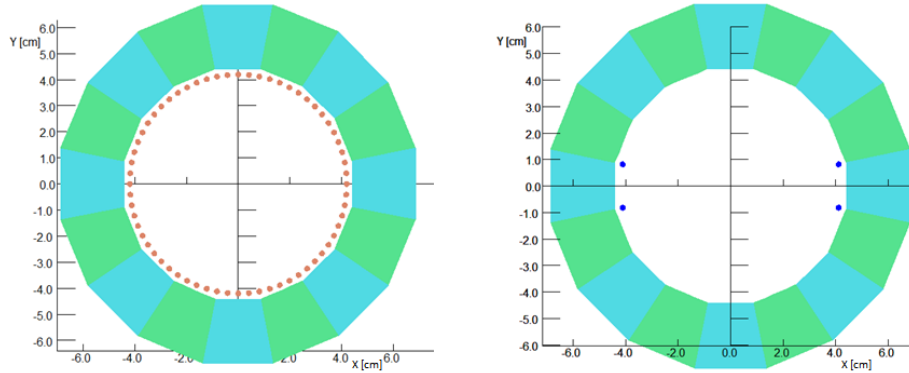

Figure 10. The cross section of a Halbach magnet (left). The little brown circles or slots indicate position for the insertion of magnetic wires. The right picture is the same as the left with the blue circles representing magnetic wires which will modify particular multipoles of the magnet. The empty wholes or slots are not shown in the right picture.

As an example which demonstrates the use of the magnetic wires to modify the multipoles of the magnet we present in Table IV the integrated field of the multipoles generated at a radius $r=2$ cm from a quadrupole Halbach magnet with no wires (2nd row) and the multipoles of the same magnet with four magnetic wires (3rd row) as shown in the right picture.

Table IV. The Integrated fields of the multipole field generated at a radius $r=2$ cm from the quadrupole Halbach magnet (Fig. 10 left) with no correction wires (2nd row), and those generated by the quadrupole Halbach magnet (Fig. 10 right) with four correction wires (3rd row)

| | Dipole [Gauss.cm] | Quad [Gauss.cm] | Sext [Gauss.cm] | Oct [Gauss.cm] | Dec [Gauss.cm] | Duodec [Gauss.cm] |
|--------------------|-----------------------|--------------------|----------------------|-----------------------|-----------------------|----------------------|
| Halbach | -1.8×10^{-8} | -0.363 | 1.3×10^{-7} | 1.6×10^{-9} | 1.8×10^{-9} | 7.2×10^{-9} |
| Halbach with wires | 1.4×10^{-6} | -0.362 | 5.9×10^{-6} | 2.95×10^{-4} | -4.5×10^{-7} | 3.1×10^{-5} |

The results in Table IV have been obtained using the OPERA computer code [4] and show that by inserting the four magnetic wires one can affect the octupole multipole of the magnet. The placement of

the wires to affect specified multipoles has been automated by using a homemade computer code which for now, although it is not complete as the OPERA computer code, provides results that allows the correction of the multipoles.

4. A DIPOLE CORRECTOR MAGNET FOR THE HALBACH MAGNET

A low field electromagnet has been placed upstream of the dipole Halbach magnet to provide a $\pm 5\%$ field adjustment in the field of the Halbach magnet. This corrector electromagnet is a window frame type which fits in the available drift space upstream of the Halbach magnet. Fig. 11 is an isometric view of the Halbach magnet followed by the dipole corrector electromagnet. The pipe to the right of the magnet is the vacuum pipe for the 114 MeV electron beam. The vacuum pipe and the pipe which surrounds the wedges of the Halbach magnet should be of magnetic material to minimize the field along the trajectory of the 114 MeV beam which is along the axis of the vacuum pipe.

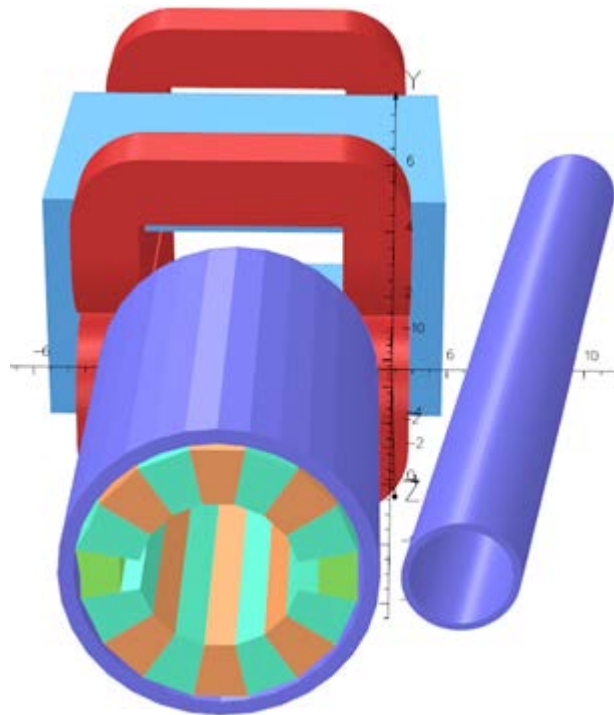

Figure 11. An isometric view of the dipole corrector electromagnet downstream of the Halbach dipole magnet. The electromagnet can provide a field variation of $\pm 5\%$ of the dipole field of the Halbach magnet. The pipe next to the magnets is the vacuum pipe for the 114 MeV beam.

5. CONCLUSIONS

A 20 cm long electromagnet as it was originally suggested to be used for the S4.BEN01 electromagnet of the splitter line provides variable magnetic field with good homogeneity but for high manufacturing cost and high cost of its power supply. Alternatively the 12 cm long Halbach type permanent magnet is smaller in size easier and less expensive to manufacture and it does not require a power supply. In addition the field homogeneity of the Halbach magnet is comparable to that of the electromagnet. A 10 cm long low field electromagnet can be used to provide $\pm 5\%$ variation of the field of the dipole Halbach magnet to adjust the trajectory of the 150 MeV reference particle. A modified Halbach magnet can mitigate the radiation effect on the permanent magnet material, and also provide a dipole field with good homogeneity comparable to that of the electromagnet.

REFERENCES

1. C. Mayes “The CBETA project” arXiv.org/abs/1504.00588 (2015)
2. The BMAD computer code.
3. K. Halbach, “Design of permanent multipole magnets with oriented rare earth cobalt material”, NIM 169 (1980) pp. 1-10 [http://dx.doi.org/10.1016/0029-554X\(80\)90094-4](http://dx.doi.org/10.1016/0029-554X(80)90094-4)
4. Vector Fields Inc.
5. <http://holbert.faculty.asu.edu/eee460/IonizationRange.pdf>
6. http://www-pub.iaea.org/MTCD/publications/PDF/trs188_web.pdf
7. Thomas Roser, Private communication
8. N. Tsoupas, et al. “Magnetic Field Calculations for a Large Aperture Narrow Quadrupole” Proceedings of the 2003 Particle Accelerator Conference

APPENDIX A

A.1 THE S4.BEN01 ELECTROMAGNET

A1.1 Layout of the S4.BEN01 electromagnet

The S4.BEN01 magnet is one of the dipole magnets in the 150 MeV line of the splitter/combiner of the CBETA accelerator. Fig. 1 shows the location of this magnet relative to the rest of the magnets in the splitter section. Due to space constraints in the region of the S4.BEN01 magnet, the available longitudinal space for the iron of the S4.BEN01 electromagnet is 20 cm. Fig. A1 is the cross section of the electromagnet at the median plane, the red areas represent the coils of the magnet. The walls of the vacuum chamber are the thin orange stripes, and the light-green thin quadrilateral region is the coil-retaining nonmagnetic sheet. The yellow quadrilateral region is the vacuum pipe of the 114 MeV beam. The vacuum pipe of the 114 MeV beam should be made of magnetic material. The x and y axes in the figure show the global coordinates.

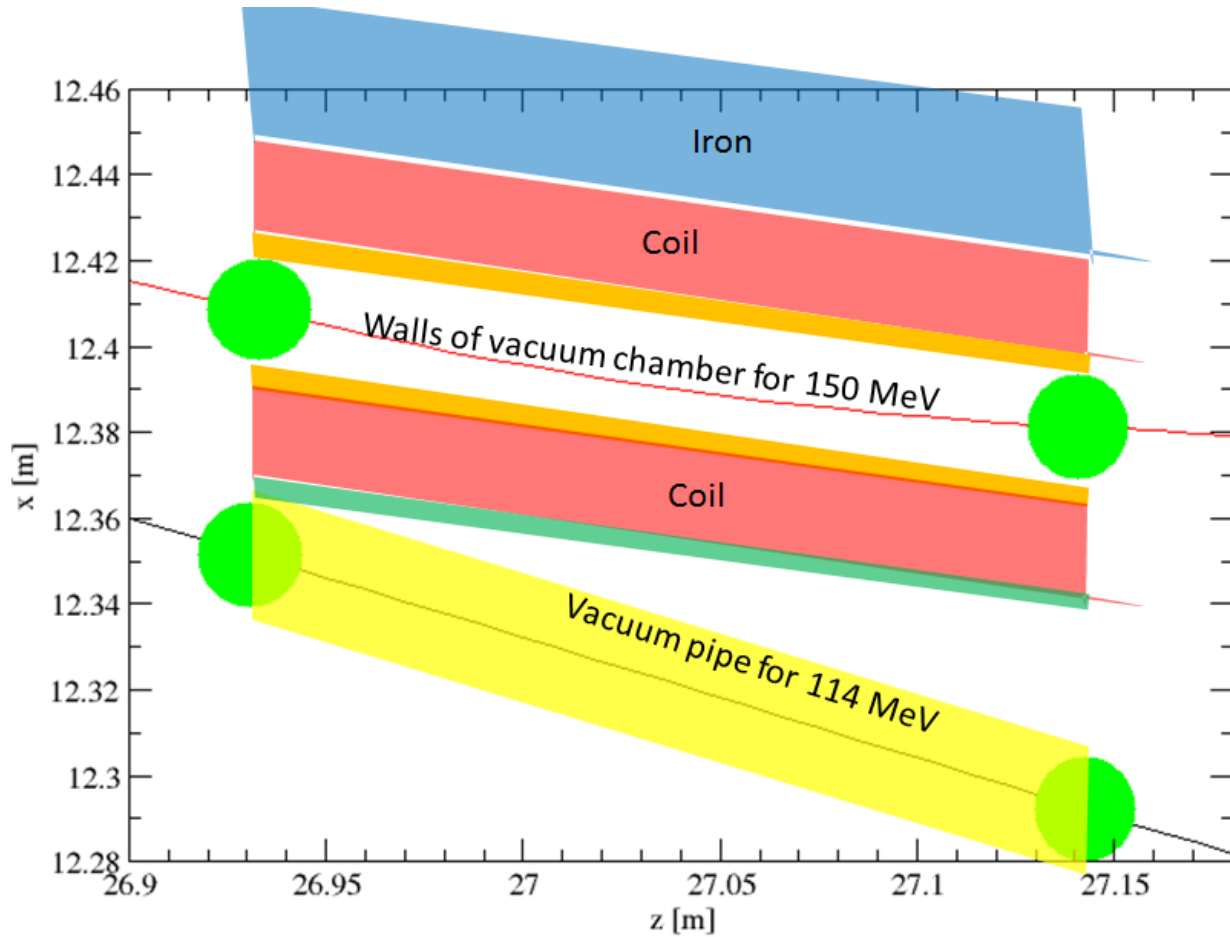

Figure A1. The schematic diagram of the cross section at the median plane of the S4.BEN01 electromagnet. The thin traces on the figure are the trajectories of the reference particles for the 114 and 150 MeV electron bunches. The center of the green circles on the figure represent the reference particles of the 114, and 150 MeV bunches at the entrance and exit of the magnet. The red areas represent the coil of the magnet. The walls of the vacuum chamber are the thin orange stripes, and the green stripe is the coil-retaining nonmagnetic sheet. The yellow quadrilateral region is the vacuum pipe of the 114 MeV beam.

The strength of the 0.2 m long S4.BEN01 magnet which is 0.406167 [T] and the angle of bend of the 150 MeV high energy bunch appears in column four of Table AI. The global beam coordinates of the reference particles for the 114 and 150 MeV beams appear in the rest of the columns of Table AI

Table AI. The kinetic energy of the 114, and 150 MeV electron bunches and the angle of bend in the 150 MeV bunch in the S4.BEN01 magnet. The coordinates of the reference particles of the 114, and 150 MeV bunches at the entrance and exit of the magnet appear in the last six columns.

| KE [GeV] | gamma | P [GeV/c] | Ang. Bend [deg] | Entrance | | | Exit | | |
|----------|---------|-----------|-----------------|--------------|-----------------|--------------|---------------|------------------|---------------|
| | | | | x_{in} [m] | x'_{in} [deg] | z_{in} [m] | x_{out} [m] | x'_{out} [deg] | z_{out} [m] |
| 0.114 | 224.092 | 0.1145 | 0.0 | 12.35158 | -15.6578 | 26.9309 | 12.29221 | -15.6578 | 27.14276 |
| 0.150 | 294.542 | 0.1505 | 9.30225 | 12.40842 | -11.8948 | 26.9330 | 12.38121 | -2.59254 | 27.14101 |

A1.2 Specifications of the S4.BEN01 electromagnet

The schematic diagram of the S4.BEN01 magnet's cross section on the median plane is shown in Fig. A1. Only the 150 MeV high energy bunch is bend by the magnet. The yellow stripe in Fig. A1, around the 114 MeV trajectory is the 0.2 cm thick vacuum pipe which is made with magnetic material and is copper plated inside. The thin orange stripes are the walls of the 0.2 cm thick vacuum chamber, and the green stripe is the 0.2 mm thick nonmagnetic coil-retaining plate. The vacuum pipe of the 114 MeV beam bunch is made of magnetic material to act as a magnetic shield for the 114 MeV beam bunch. From the values of the coordinates in Table A1 the distance of the reference particles of the 114 MeV and the 150 MeV beam bunches at the entrance of the magnet is 5.68 cm therefore the magnet should be a septum like magnet. The central particles of each of the four bunches should be at least 1.2 cm away from any material. This constrain is taken into account in the design of the magnet. Table AII contains the specifications of the S4.BEN01 septum magnet. Column 3 is the angle of bend for 150 MeV electrons. The vertical aperture of the magnet is column 5 and the "septum-thickness" which is defined in this technical note as the available transverse space for the copper coil is in column 6. The current density is 1400 A/cm².

Table AII. S4.BEN01 Magnet specifications

| Length [m] | | B _{field} [T] | Bend angle | Sagitta [cm] | Gap [cm] | Septum [cm] | Hor. Aper. [cm] | Current [A.turns] | J [A/cm ²] |
|---------------|--|---------------------------|---------------|-----------------|-------------|----------------|--------------------|----------------------|---------------------------|
| 0.2 | | 0.40617 | 9.3° | 0.2 | 3.4 | 2.68 | 3.5 | 10990 | 1400 |

The septum-thickness which the available space to place the conductors of the coil is calculated in the following way.

septum-thickness=(central particles spacing between 114 and 150 MeV bunches)-2x(dist. of ref. part. from chamb.)-3x(chamb thickness)=5.68 cm-2x1.2 cm-3x0.2 cm=2.68 cm.

A.2 THE ELECTROMAGNETIC DESIGN OF THE ELECTROMAGNET

In the next two subsections we discuss the results from the 2D and 3D electromagnetic design of the S4.BEN01 Septum. Both the 2D and the 3D modeling of the magnet were performed with the OPERA computer code.

A2.1 The 2D design of the S4.BEN01 electromagnet

A cross section of the dipole septum-type electromagnet is in shown Fig. A2. The blue circular pipe on the figure is the 114 MeV vacuum pipe which should be of magnetic material to shield magnetically the 114 MeV electron beam. The region with the blue color is the iron of the magnet, and the red-colored regions are the conductors of the magnet's coil. In this study we assume 8 conductors per coil.

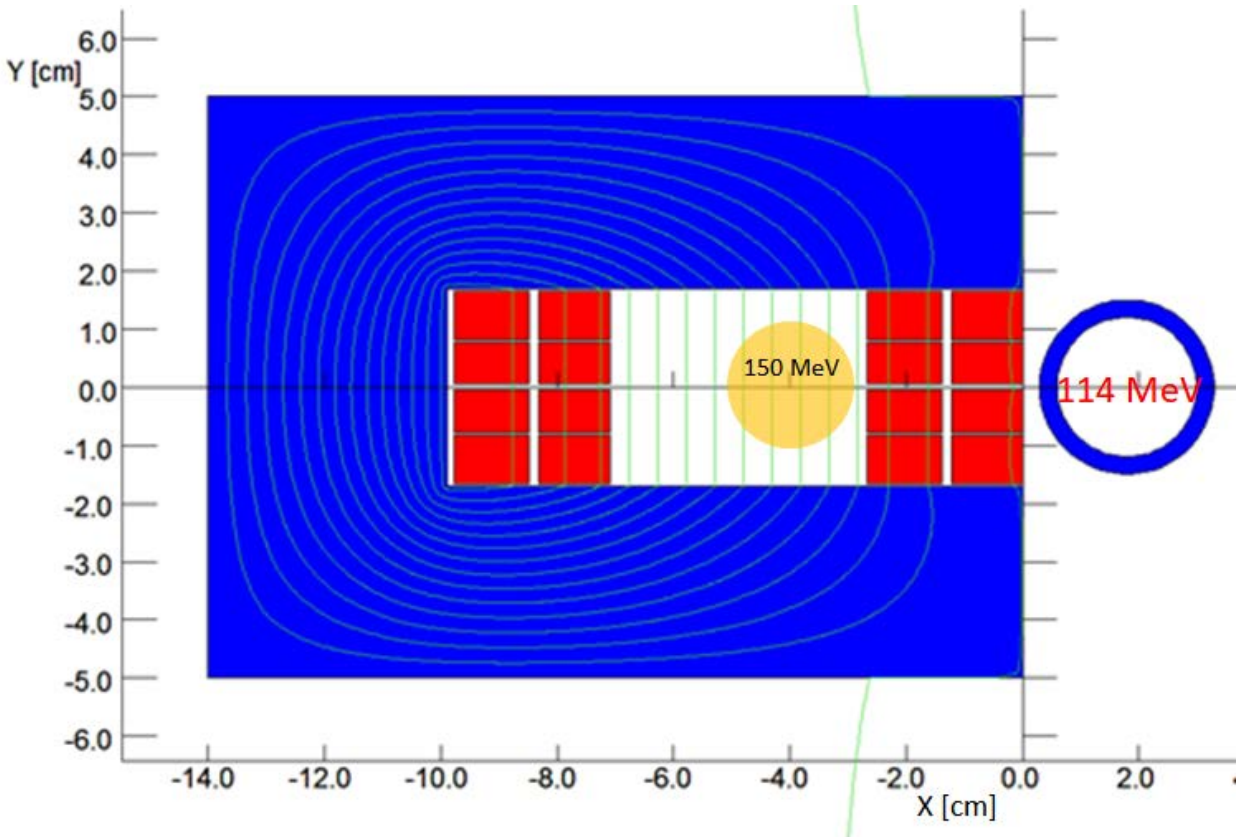

Figure A2. The cross section of the S4.BEN01 septum magnet. The blue-colored regions represent magnetic iron, and the red-colored regions are the conductors of the coil. In this study we assume 8 conductors for the coil of the magnet.

The B-field in the magnet is 0.40617T with a current density of 1400 A/cm². The field homogeneity in the region where the 150 MeV beam is shown in Fig. A3.

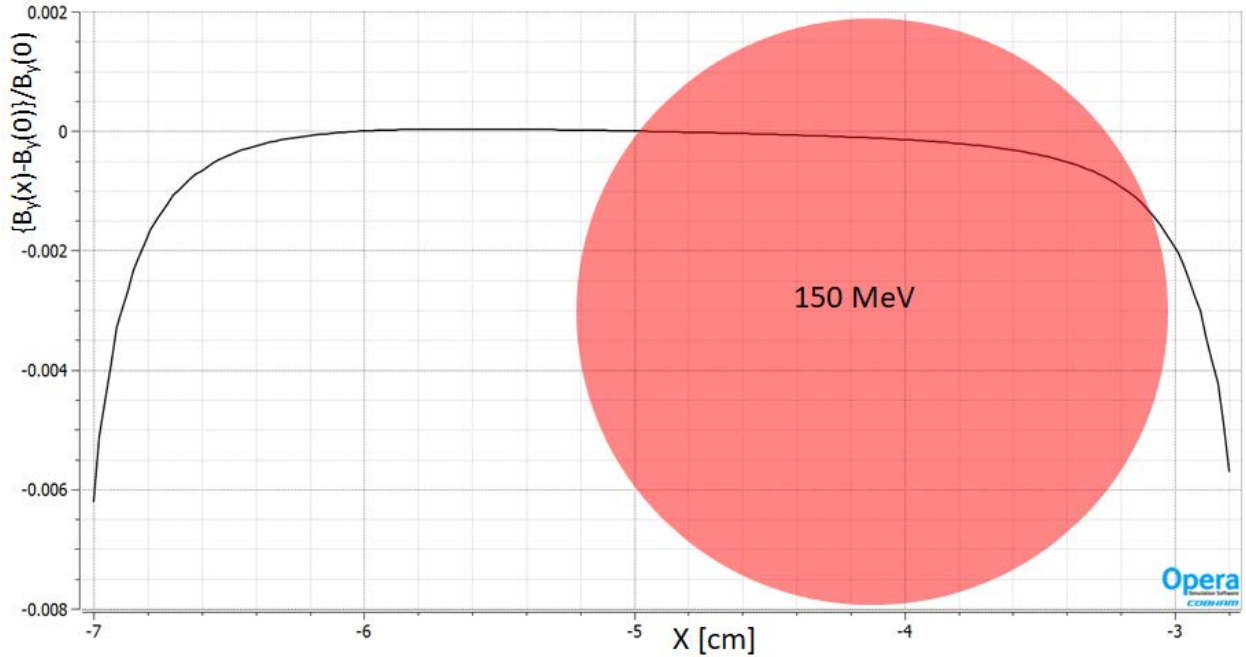

Figure A3. The field homogeneity of the dipole septum magnet. The wall of the septum is at -3 cm. The red circle shows the area for the 150 MeV beam. The field homogeneity $\Delta B/B$ in the area of the beam is better than 10^{-3} .

Fig. A4 shows that the 3 cm thick iron yoke is sufficient to keep the iron below saturation.

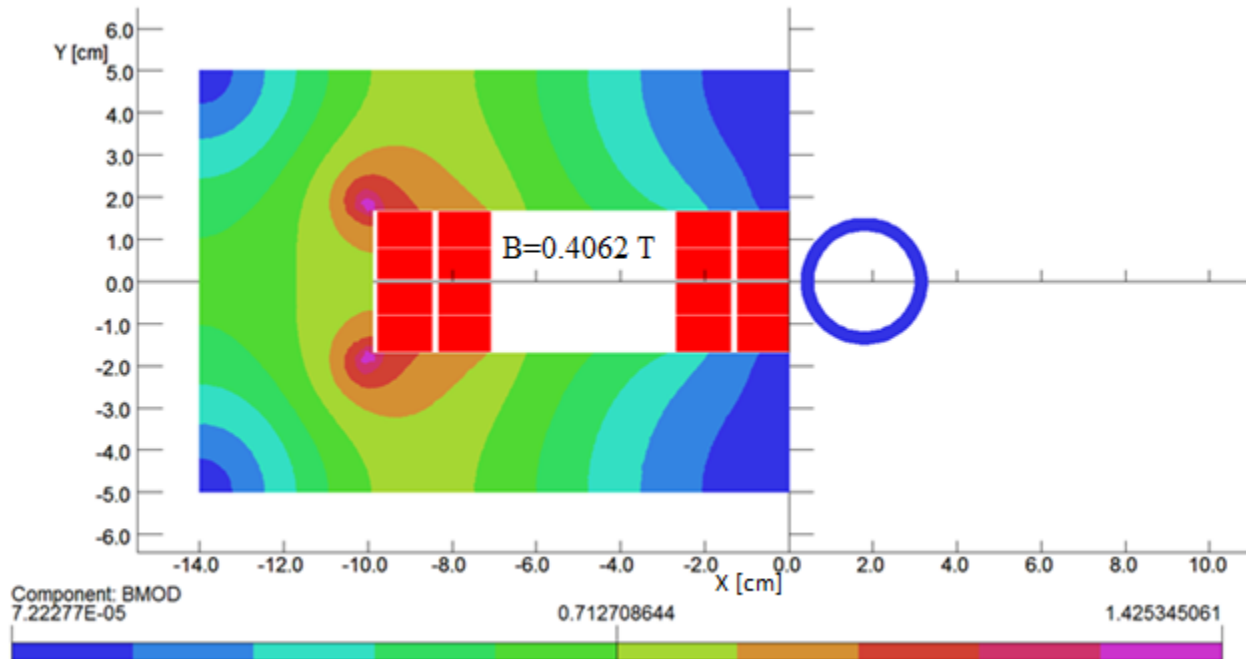

Figure A4. The maximum modulus of the magnetic field of 1.42 T of the iron yoke indicates that the magnet runs below saturation.

The vacuum pipe of the 150 MeV beam is made of magnetic iron and serves to shield the beam from the magnetic field generated by the magnet. The maximum value of the magnetic field modulus inside the vacuum pipe of the 114 MeV is less than 9×10^{-7} T if the beam pipe is of magnetic material. If the beam pipe of the 114 MeV beam is of nonmagnetic material the corresponding value of the magnetic field modulus is 5.3 Gauss.

A2.2 The 3D design of the S4.BEN01 electromagnet

An isometric view of the septum magnet is shown in the upper left and right pictures of Fig. A5. Both models are identical except that the upper right model has a longer pipe of magnetic material to reduce the magnetic field inside the 114 MeV beam pipe.

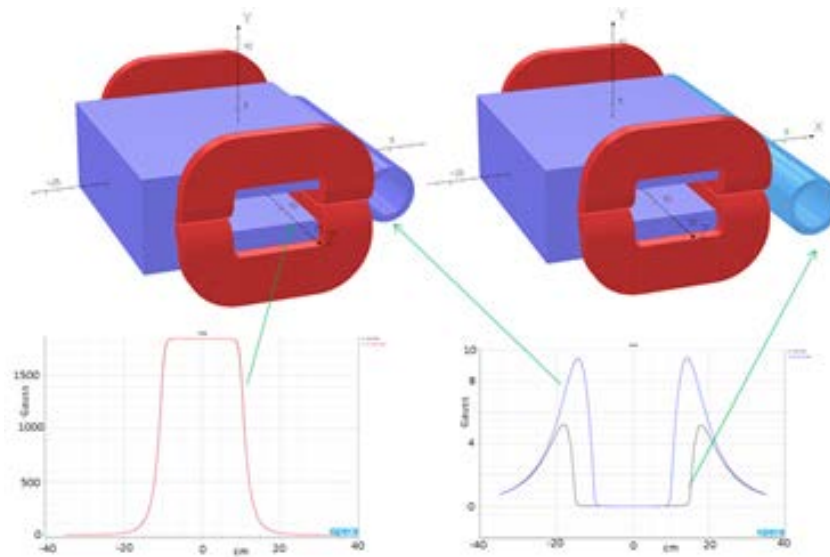

Figure A5. a) (Upper left) isometric view of the S4.BEN01 septum magnet, with the magnetic pipe for the 114 MeV beam. b) (Upper right) the same magnet as in (a) but with a longer vacuum pipe for better magnetic shielding of the 114 MeV beam. c) (Bottom left) The magnetic field inside the magnet as a function along the z-axis. d) (Bottom right) The magnetic field along the 114 MeV trajectory for the short and the long magnetic pipes respectively.

The cylindrical pipe on the right side of the magnet is the vacuum pipe for the 114 MeV beam and is made of magnetic material to minimize the magnetic field of the magnet along the trajectory of the 114 MeV beam. The plot on the bottom right of the picture is a graph with two plots of the magnetic field along the center of the vacuum pipe. One of the plots corresponds to the field with the short pipe (magnet in upper left corner) and the other plot to that of the magnet with the long pipe (magnet in upper right corner). The comparison of the two plots shows that the longer magnetic pipe reduces the magnetic field along the trajectory of the 114 MeV beam.